

SU-A

SF

SA-C

Travel Drives
Operating and Maintenance Instructions

↘ EN

Fundamental information

You have purchased a product manufactured by STAHL CraneSystems GmbH. These crane components have been constructed in compliance with the applicable standards and regulations.

Inspect components for damage caused in transit immediately upon delivery.

Report damage caused in transit and after consulting the manufacturer/supplier repair or have repaired before installation and commissioning. Do not install or commission damaged components!

- **Assembly**
- **installation**
- **commissioning**
- **testing**
- **maintenance and fault clearance**

may only be carried out by a qualified person

Terms employed

User

Whoever uses and employs the crane components or has them operated by suitable trained personnel is considered to be the user (employer/company).

Trained personnel

Trained personnel are persons who have been instructed and trained in the duties with which they are entrusted and the risks which may arise from incorrect behaviour, have been advised on the necessary protective devices, precautions, applicable regulations, accident prevention regulations and prevailing conditions and have proven their ability.

Skilled electrician

A skilled electrician possesses knowledge and experience on electrical equipment arising from specialist training and, with knowledge of the applicable standards and regulations, is able to assess the work with which he is entrusted and detect and avoid possible risks.

Definition of a qualified person (specialist):

A qualified person is one with the necessary qualification, based on theoretical and practical knowledge of hoists, for the required activities as listed in the operating instructions.

The person must be in a position to assess the safety of the installation in conjunction with the application.

Persons with the authority to undertake certain maintenance work on our products include service engineers of STAHL CraneSystems GmbH and trained fitters with the corresponding certification.

Seminars:

Comprehensive understanding of material handling products is a prerequisite for the correct use of equipment. Competent and practically oriented, we impart the specialist knowledge required for the correct use, monitoring and care of your installation. Ask for our seminar programme → you will find information on it on the last page.

1	Safety instructions	1.1 Symbols	4
		1.2 Operating instructions	4
		1.3 Use for intended purpose	5
		1.4 Safety-conscious operation.....	5
		1.5 Organisational safety precautions.....	5
		1.6 General regulations	5
		1.7 Installation, commissioning, maintenance and repairs	6
		1.8 Warranty.....	6
		1.9 Periodic tests.....	6
		1.10 After sales service.....	6
2	SU-A travel drive	2.1 Installation	7
		2.1.1 Description.....	7
		2.1.2 Permissible mounting position	7
		2.1.3 Electrical connection	8
		2.2 Maintenance	8
		2.3 Maintenance work	9
		2.3.1 Inspection and maintenance table	9
		2.3.2 Travel motor brake.....	9
		2.3.3 Grease change.....	10
		2.4 Motor data	11
		2.5 Sound pressure level	12
		2.6 Operating conditions.....	12
		2.7 Wearing parts.....	12
3	SF travel drive	3.1 Installation	13
		3.1.1 Description.....	13
		3.1.2 Permissible mounting position	13
		3.1.3 Electrical connection	14
		3.2 Maintenance	15
		3.3 Maintenance work	15
		3.3.1 Inspection and maintenance table	15
		3.3.2 Travel motor brake.....	16
		3.3.3 Replacing brake disc.....	16
		3.3.4 Gear.....	17
		3.3.5 Oil change	17
		3.4 Motor data	18
		3.5 Sound pressure level	20
		3.6 Operating conditions.....	20
		3.7 Wearing parts.....	21
4	SA-C travel drive	4.1 Installation	22
		4.1.1 Description.....	22
		4.1.2 Permissible mounting position	22
		4.1.3 Electrical connection	23
		4.2 Maintenance work	24
		4.3.1 Inspection and maintenance table	24
		4.3.2 Travel motor brake.....	25
		4.3.3 Gear.....	26
		4.3.5 Oil change	26
		4.4 Motor data	27
		4.5 Sound pressure level	29
		4.6 Operating conditions.....	29
		4.7 Wearing parts.....	30
5	General information	5.1 Seminar programme.....	31

1 Safety instructions

1.1 Symbols



Safety at work

This symbol marks all information on safety at work where risks to life and limb are entailed.



Warning of electrical voltage

Covers such as hoods and caps which are marked with this symbol may only be opened by "qualified persons or suitably instructed personnel".



Warning of suspended load

It is forbidden for persons to stand under suspended loads. This entails risks to life and limb!



Safety in operation

Information marked with this symbol must be observed to avoid causing damage.

In these operating instructions, these symbols mark particularly important information on risks and safety in operation.

1.2 Operating instructions

Read carefully and observe the operating instructions.

1 Safety instructions

1.3 Use for intended purpose

- The travel drives are intended for driving cranes and similar installations. They may only be used in accordance with their design principles.
- Do not carry out any alterations or modifications. Additional fitments must be authorised by the manufacturer. Non-compliance will invalidate the declaration of conformity.

1.4 Safety-conscious operation



The travel drives are constructed according to the state of the art. In spite of this, dangers may arise from incorrect use or use for an unintended purpose.

- The operator is responsible for ensuring that work is carried out with safety in mind and avoiding risks, see page 2.
- Read the operating instructions before starting work.
- Before starting work, find out where the EMERGENCY STOP button is (usually in the control pendant).
- Report damage and defects to the travel drives (abnormal noises, impaired braking function, deformations, ...) to the person responsible immediately. Do not use the system until the faults have been eliminated.

1.5 Organisational safety precautions

- Only direct persons to operate the system if they have been trained or instructed in its use. Observe the legal minimum age! You will find information on our seminar programme on the last page.
- At regular intervals, check that work is being carried out in a safety-conscious manner.
- Observe the intervals specified for periodic tests. File the test reports in the test log book.
- Store the operating instructions within easy reach where the travel drives are operated.

1.6 General regulations

- Safety regulations and accident prevention regulations.
- Statutory regulations relating to the EC Directive.
- National regulations

1.7 Installation, commissioning, maintenance and repairs

- **Installation, commissioning, maintenance and repairs may be carried out by qualified persons only**, see page 2.
- We recommend having installation carried out by the manufacturer's personnel.
- Use only **original spare parts** for repairs, otherwise the guarantee will become invalid.
- Additional fitments must not prejudice safety.
- Electrical connection and the electrical function test may only be performed by a trained electrician.
- Our after-sales service will advise you on correct use of the equipment. Repairs will be carried out professionally and quickly by our trained personnel. You will find information on this on the back cover.

1 Safety instructions

1.8 Warranty

- The warranty will become invalid if these operating instructions are not observed for installation, operation, inspection and maintenance.
- Repairs and elimination of faults within the scope of the warranty may only be performed by qualified personnel (see page 2) after the manufacturer/supplier has been consulted and has given his approval.

The warranty will become invalid if the travel drives are modified or original spare parts not used

- Die Gewährleistung erlischt, wenn die Montage, Bedienung, Prüfung und Wartung nicht nach dieser Betriebsanleitung erfolgt.
- Reparaturen und Störungsbeseitigungen im Rahmen der Gewährleistung dürfen nur von Fachkräften (siehe Seite 2) nach Rücksprache und Beauftragung durch den Hersteller ausgeführt werden.

Bei Änderungen an den Fahrtrieben sowie bei Einsatz von nicht Original-Ersatzteilen erlischt die Gewährleistung

1.9 Periodic tests



Travel drives must be inspected by a **qualified person**, see page 2 at least once a year, possibly more frequently if so required by national regulations. The results of the test must be recorded and filed in the test log book.

The periodic tests must be adapted to the use of the crane components. Intensive use entails shorter maintenance intervals.

All tests must be initiated by the user (see page 2).

1.10 After sales service

With the purchase of these travel drives, you have decided on a high-quality product. Our after sales service will give you advice on its correct use. You will find information on our after-sales service on the back cover.

In order to maintain the safety and constant availability of your wire rope hoist, we recommend concluding a maintenance agreement on the basis of which we will undertake the "periodic tests" on your behalf.

Repairs will be carried out professionally and quickly by our trained personnel.

2 SU-A travel drive

2.1 Installation

2.1.1 Description

The travel drives are high-quality drives with smooth starting and braking characteristics as is required in particular for material handling.

The drive shaft is equipped with a pinion or a cylindrical shaft with groove for a feather key as desired.

It can be further extended with a flange bearing with pinion and a drive shaft.

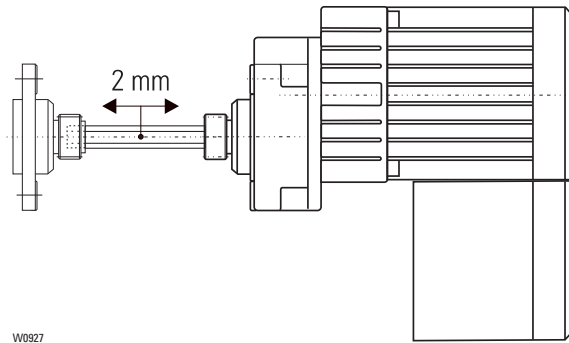

W0927

2.1.2 Permissible mounting position

- The travel drive can be rotated around its main horizontal axis in 90° steps.
- Use screws in grade 8.8 for attachment and tighten them with the prescribed tightening torque.

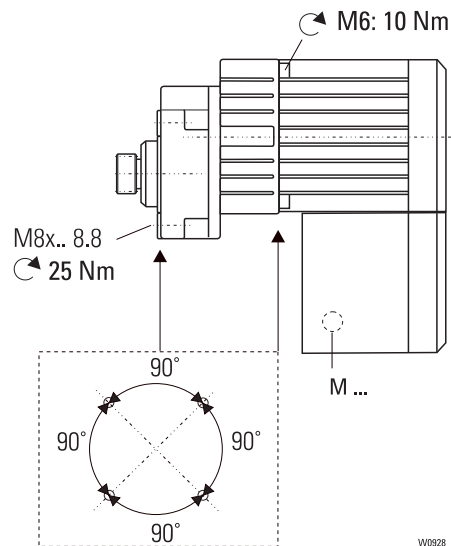

W0928

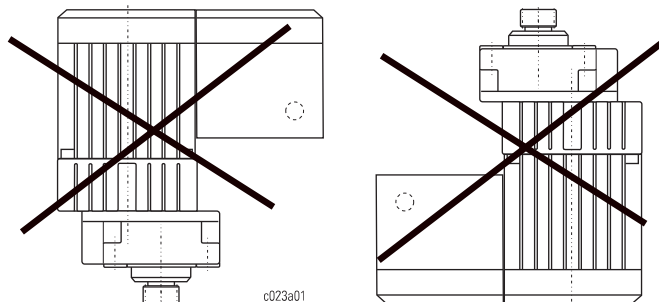

c023a01

2 SU-A travel drive

2.1 Installation (continued)



2.1.3 Electrical connection

- The mains voltage must match that given on the rating plate.
- Electrical connection with plug connection or cable gland.
- If using cable gland, follow the terminal diagram.

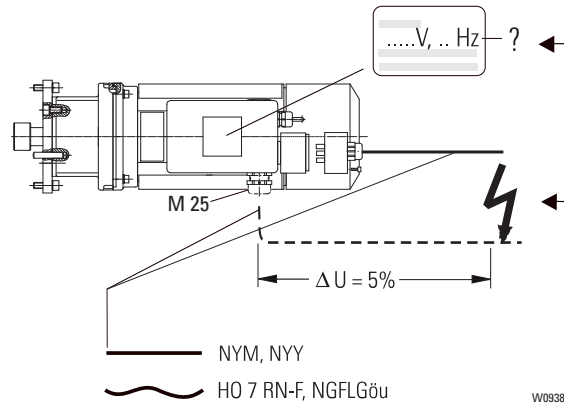

Block terminal diagram

A04 motor

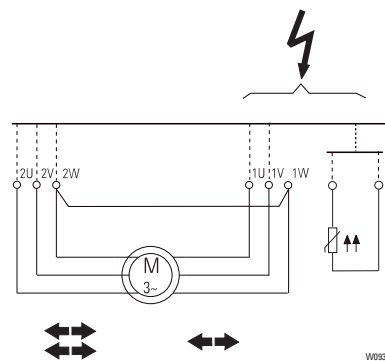

Standard settings for frequency inverter

Speed m/min	8	10	12,5	16	20	25	32	40	50	63	80	100
Max. frequency Hz	80	100	50	63	80	100	80	100	80	100	100	100
Motor connection	Δ	Δ	Y	Y	Δ	Δ	Δ	Δ	Δ	Δ	Δ	Δ
Run-up time [s]	2,1	2,4	2,8	3,3	3,8	4,2	4,7	5,2	5,6	6,0	6,7	8,4
Stopping time [s]	1,7	2,0	2,3	2,7	3,0	3,4	3,8	4,2	4,5	4,8	5,4	6,7

2.2 Maintenance



This section deals with the operational reliability, availability, and maintaining the value of your travel drives.

Although they are practically maintenance-free, the components subject to wear must be inspected regularly. This is required by the accident prevention regulations. The inspections must be performed by **qualified personnel**, see page 2.

General information on inspection and maintenance

- Maintenance and repair work may only be carried out when the crane is not under load.
- Switch off and padlock main isolator.
- Follow the accident prevention regulations.

Please also note the "Safety instructions" on page 5.
Wearing parts, see page 12.

2 SU-A travel drive

2.3 Maintenance work

2.3.1

No.	Inspection on commissioning*1	Daily inspection on starting work*2	Periodic inspections every 12 months*3	Periodic maintenance every 12 months*2	Maintenance after 10 years or general overhaul*4	Inspection and maintenance table (Classification: 1 Bm)	See page
1			•			Attachment of travel drive	7
2	•	•	•			Check braking effect of travel drive	
3					•	Change grease in travel drive	10

*1 By a fitter engaged by the manufacturer

*2 By the operator

*3 Periodic maintenance every 12 months, possibly earlier if so prescribed by national regulations, to be performed by a fitter engaged by the manufacturer.

Similarly, heavy-duty applications and adverse conditions (dirt, solvents, multi-shift operation etc.) necessitate shortening this inspection and maintenance interval.

*4 In manufacturer's works.

2.3.2 Travel motor brake

Check brake at regular intervals. The intervals must be adapted in accordance with the application.

- Move carriage into a safe position
- Measure displacement of motor shaft. To do so, switch motor on briefly, see sketch.
- The travel motor brake need not be adjusted.
- If $X \geq 2,5$ mm, replace brake disc (gear housing).

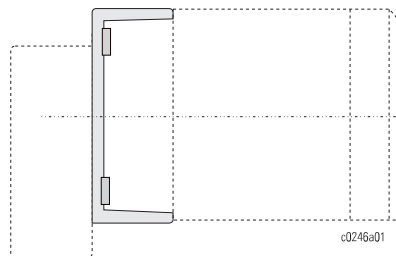
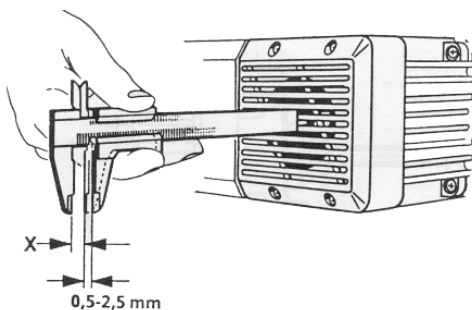

Replacement and repairs may only be carried out by qualified personnel!

2 SU-A travel drive

2.3 Maintenance work

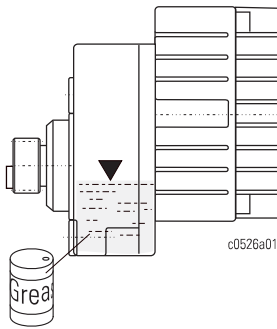
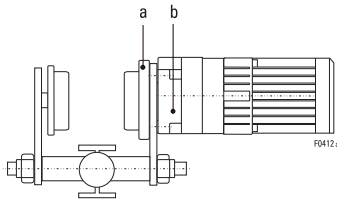

2.3.3 Gear

The gear has a long service life. All bearing points have roller bearings. The gearing is hardened, hard-machined and has high safety factors.

- Note any gear noises from the crane when under load and without load. Rough, noisy running, knocking sounds indicate possible faults.
- If any faults are detected, repairs must be scheduled.
- If there is any uncertainty, a fresh diagnosis can be made after consulting experts, e.g. from the manufacturer (see back cover).

2.3.4 Changing grease of travel drive Lubricating toothed boss of wheel

The SU-A travel drives have a gear with grease lubrication. The toothed boss (a) is lubricated with grease (see table).

The type and quantity of oil or grease can be seen from the table.

Position of lubrication point		Type of lubricant	Designation	Quantity	Charakteristics, makes	Order. No.
a	Toothed boss of wheel	Grease	KPF 1K	50 gr	Soap base: Lithium + MoS ₂ Dripping point: approx. 185°C (180°C) Penetration: 310-340 (310-340) Operating temperature: -20° to +120°C, (-50° to +150°C), e.g.: Aral Fett P 64037*, Aralub PMD1, BP Multi-purpose Grease L21M, Esso Multi-purpose Grease M, Mobil Grease Special, Shell Retimax AM *1, Texaco Molytex Grease EP2, Fuchs Renolit FLM2, (Fuchs Renolit FLM2)	
b	SU-A 1.4.1. SU-A 1.4.2.	Grease	KPOK	130 gr 200 gr	Soap base: Lithium + MoS ₂ Dripping point: approx. +180°C Penetration: 355-385 Operating temperature: -30° to +130°C e.g.: Aral Fett P64037*, Aralub PMD0, Tribol Molub-Aloy Mehrzweckfett	32 250 09 65 0 (0.75 kg)

() = Lubricants for low operating temperatures, max. -30°C

* Factory filling

*1 Only down to -20°C

2 SU-A travel drive

2.4 Motor data

SU-A..	50 Hz
---------------	--------------

Index No.	Type	P	n1	TN	TA	TH	TB	Jrot	Jschw	cos φ N	cos φ K	DC	Ac	Wmax	PB
		kW	1/min	Nm	Nm	Nm	Nm	kgm ²	kgm ²			%	[(1/h)s]	J/br	W
43	2/8 A04/507	0,07	595	1,14	2,5	1,8	1,3	0,0035		0,67	0,84	20	450	-	-
		0,32	2670		2,6	2,1	0,74								

Index No.	Type	In			Ik		
		220...240V	380...415V	480...525V	220...240V	380...415V	480...525V
43	2/8 A04/507	[A]	[A]	[A]	[A]	[A]	[A]
		1,9 2,1	1,1 1,2	0,9 1,0	2,1 5,6	1,2 3,2	1,0 2,6

SU-A..	60 Hz
---------------	--------------

Index No.	Type	P	n1	TN	TA	TH	TB	Jrot	Jschw	cos φ N	cos φ K	DC	Ac	Wmax	PB
		kW	1/min	Nm	Nm	Nm	Nm	kgm ²	kgm ²			%	[(1/h)s]	J/br	W
43	2/8 A04/507	0,09	710	1,14	2,5	1,8	1,3	0,0035		0,62	0,80	20	385	-	-
		0,38	3200		2,6	2,1	0,82								

Index No.	Type	In			Ik		
		380...415V	460...480V	575...630V	380...415V	460...480V	575...630V
43	2/8 A04/507	[A]	[A]	[A]	[A]	[A]	[A]
		1,3 1,4	1,1 1,2	0,9 1,0	2,1 5,6	1,2 3,2	1,0 2,6

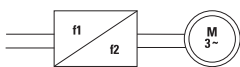
SU-A..	380...480 V, 50 / 60 Hz		380...415 V, 100 Hz
---------------	--------------------------------	--	----------------------------

Index No.	Type	fN	fN	P	P	n1	n1	TN	TA	TH	TB	Jrot	IN	IN	IK	cos φ N	cos φ K	DC	Ac	x	
		Y	Δ	Y	Δ	Δ	Δ							Y	Δ						Ω
		Hz	Hz	kw	kw	1/min	1/min	Nm	Nm	Nm	Nm	kgm ²	A	A	A			%			
44	4 A04/507	50	100	0,2	0,4	1220	2440	1,57	3,1	2,5	1,3	0,0012	0,8	1,6	1,7	0,67	0,8	60	500	34,1	

Ac	[(c:h) x s]	Switching frequency factor	n1	[1/min]	Motor r.p.m.
cos φ K		Power factor (short circuit)	PB	[W]	Coil output (brake)
cos φ N		Power factor (nominal)	P	[kW]	Motor output
DC	[%]	Duty cycle	TA	[Nm]	Motor starting torque
IK	[A]	Short circuit current	TB	[Nm]	Braking torque (motor shaft)
IN	[A]	Rated current	TH	[Nm]	Run-up torque (motor shaft)
Jrot	[kgm ²]	Moment of inertia, rotor	TN	[Nm]	Rated motor torque
Jschw	[kgm ²]	Moment of inertia, centrifugal mass	Wmax	[J/Br]	Max. permissible friction energy (brake)
Jges	[kgm ²]	Moment of inertia of motor as a whole	*1 x =		Terminal resistance

2 SU-A travel drive

2.5 Sound pressure level

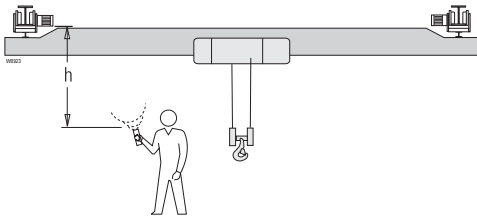

Measured at a distance of 1 m from the crane contour.

The mean sound pressure level calculated for one operating cycle (50% with nominal load, 50% without load) can be seen in the tables.

Instead of stating an emission value based on a workplace, the values from the tables at measuring distance "h" can be used.

Indoors

Type of travel drive	[db (A)] +/- 3				
	h [m]				
	1 m	2 m	4 m	8 m	16 m
SU-A ..	78	75	72	69	66

Outdoors

Type of travel drive	[db (A)] +/- 3				
	h [m]				
	1 m	2 m	4 m	8 m	16 m
SU-A ..	78	72	66	60	54

2.6 Conditions of use

The components are designed for use in industry and for the ambient conditions usual in industry.

Special measures must be taken for particular applications such as e.g. high degree of chemical pollution, outdoor use, offshore application, etc.

The manufacturer will be pleased to advise you.

Protection against dust and humidity in acc. with EN 60 529 / IEC

Standard: IP 55

Option: IP66

Permissible ambient temperatures

Standard: -20°C ... +40°C

Option: +60°

Frequency inverters can be used from -20°C to +50°C (non-dewing).

2.7 Wearing parts

SU-A 1.4..

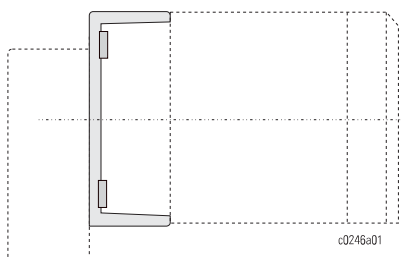

2.7.1 Brake disc (gear housing)

Order no.

51 250 79 37 0 (SU-A 1.4.1)

51 250 78 37 0 (SU-A 1.4.2)

Replacement and repairs may only be carried out by qualified personnel.

3 SF travel drive

3.1 Installation

3.1.1 Description

The travel drives are high-quality drives with smooth starting and braking characteristics as is required in particular for material handling.

The SF 11 and SF 18 can be further extended with a flange bearing with pinion and a drive shaft.

SF 11/ 18

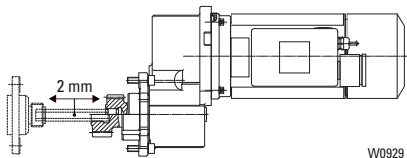

W0929

SF 14

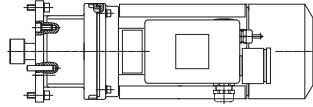

W0930

SF 15/17

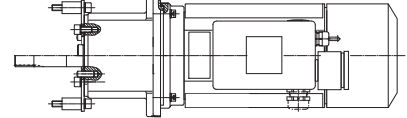

W0931

SF 25/35

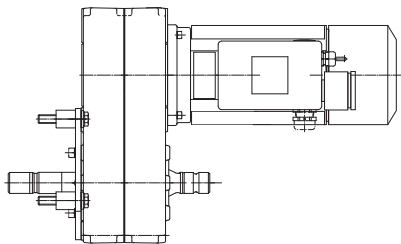

SF 25/35

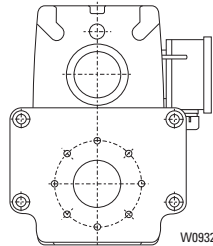

W0932

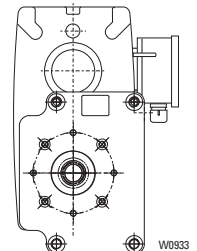
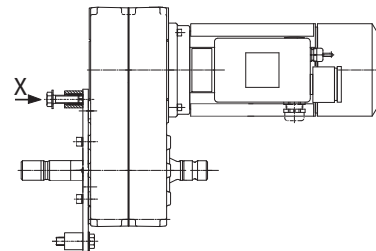

W0933



3.1.2 Permissible mounting position

- The travel drive can be rotated around its main horizontal axis in 90° steps.
Caution! A larger quantity of lubricant is required for the SF 1.2. in mounting position "motor at bottom" (see lubrication table).
- Tighten the fixing screws with the prescribed tightening torque.
- X: Screw can only be inserted in direction of arrow.
- Check oil level before commissioning. (SF 25, SF 35)

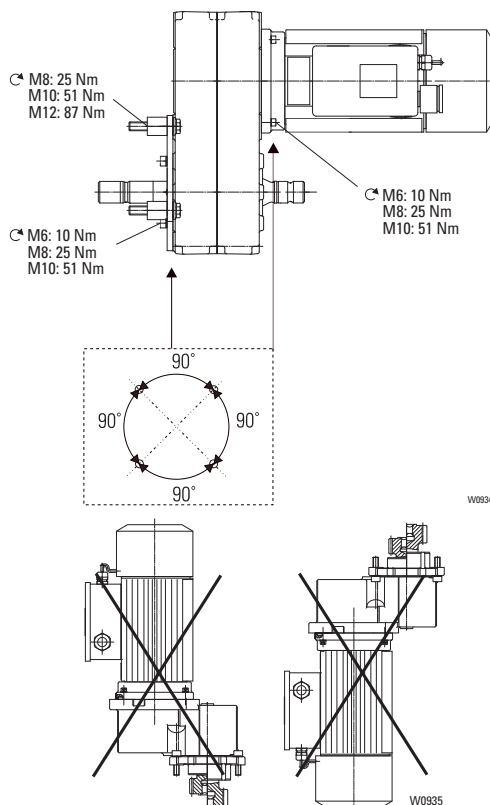

3 SF travel drive

3.1 Installation (continued)



3.1.3 Electrical connection

- The mains voltage must match that given on the rating plate.
- Electrical connection with plug connection or cable gland.
- If using cable gland, follow the terminal diagram.
-

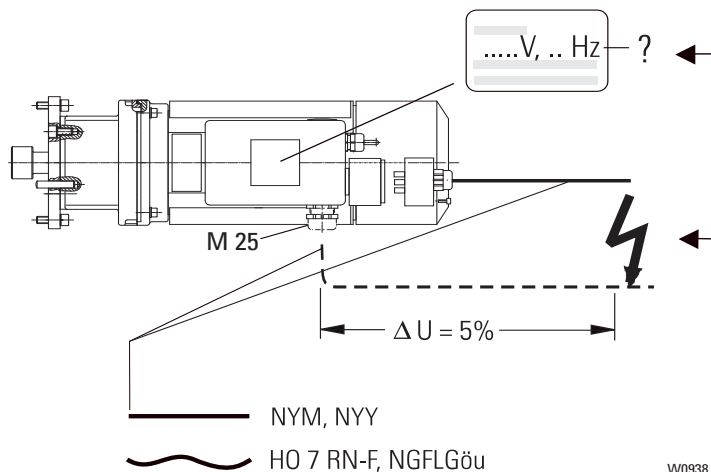

W0938

Block terminal diagram

8/2 F. motor

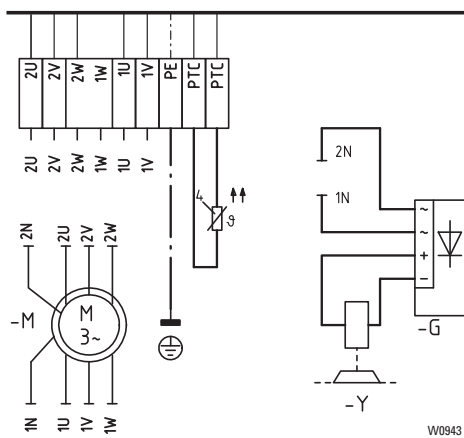

W0943

4 F. motor

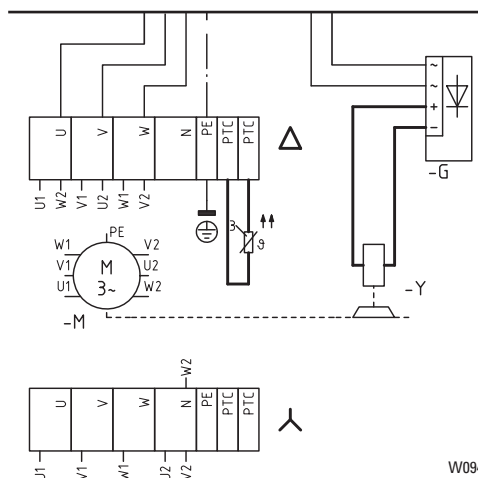

W0942

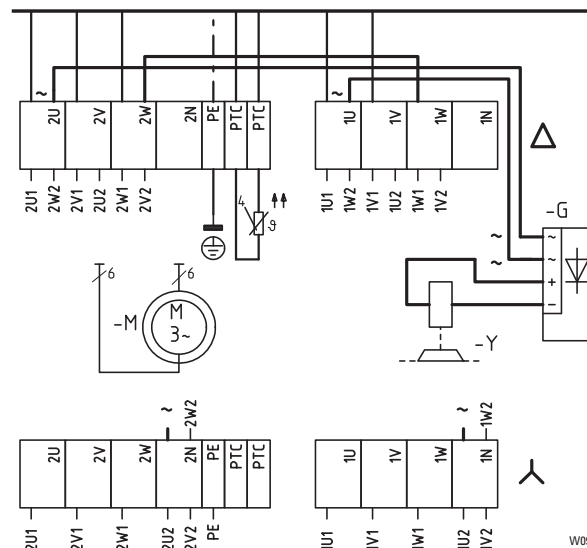

W0944

Standard settings for frequency inverter

Speed m/min	8	10	12,5	16	20	25	32	40	50	63	80	100
Max. frequency Hz	80	100	50	63	80	100	80	100	80	100	100	100
Motor connection	Δ	Δ	Y	Y	Δ	Δ	Δ	Δ	Δ	Δ	Δ	Δ
Run-up time [s]	2,1	2,4	2,8	3,3	3,8	4,2	4,7	5,2	5,6	6,0	6,7	8,4
Stopping time [s]	1,7	2,0	2,3	2,7	3,0	3,4	3,8	4,2	4,5	4,8	5,4	6,7

3 SF travel drive

3.2 Maintenance



This section deals with the operational reliability, availability, and maintaining the value of your travel drives. Although they are practically maintenance-free, the components subject to wear must be inspected regularly. This is required by the accident prevention regulations. The inspections must be performed by **qualified personnel**, see page 2.

General information on inspection and maintenance

- Maintenance and repair work may only be carried out when the crane is not under load.
- Switch off and padlock main isolator.
- Follow the accident prevention regulations.

Please also note the "Safety instructions" on page 5.
Wearing parts, see page 20.

3.3 Maintenance work

3.3.1

No.	Inspection on commissioning*1	Daily inspection on starting work *2	Periodic inspections every 12 months *3	Periodic maintenance every 12 months *2	Maintenance after 10 years or general overhaul *4	Inspection and maintenance table (Classification: 1 Bm)	See page
1			•			Travel drive: attachment, torque support	13
2	•	•	•			Check braking effect of travel drive	
3	•					Oil level	17
4					•	Change gear/oil of travel drive	17

*1 By a fitter engaged by the manufacturer

*2 By the operator

*3 Periodic maintenance every 12 months, possibly earlier if so prescribed by national regulations, to be performed by a fitter engaged by the manufacturer.

Similarly, heavy-duty applications and adverse conditions (dirt, solvents, multi-shift operation etc.) necessitate shortening this inspection and maintenance interval.

*4 In manufacturer's works.

3 SF travel drive

3.3 Maintenance work (continued)

3.3.2 Travel motor brake

Check brake at regular intervals. The intervals must be adapted in accordance with the application.

- Move carriage into a safe position
- Remove fan cover (1)
- Remove plug (2)
- Measure air gap (S) with feeler gauge (F). See table for max. permissible air gap (S).
- The travel motor brake needs no adjustment.
- If the max. permissible air gap (S) has been reached, the brake disc (brake rotor) must be replaced.

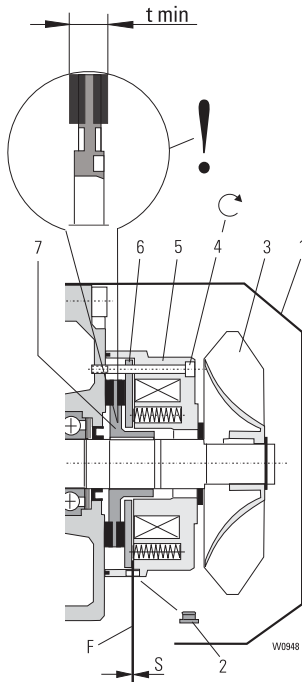

3.3.3 Replacing brake disc (brake rotor)

- Remove fan cover (1)
- Pull off fanwheel (3), remove feather key
- Disconnect brake
- Unscrew fixing screws (4)
- Remove magnet piece (5) together with armature disc (6)
- Remove brake disc (brake rotor) (7)

Replace in reverse order. Ensure that the check hole for measuring the air gap is underneath.

Travel drive	Motor type	Brake	Braking torque [Nm]	S min. [mm]	S max. [mm]	t min [mm]	(4)	⤴ Nm
SF xx xxx 123	8/2F12/2xx.223	FDW 08	1,3	0,2	2,0	5,7	3xM4	3
SF xx xxx 133	8/2F13/2xx.233	FDW 08	2,5	0,2	1,6	6,1	3xM4	3
SF xx xxx 184	4F18/2xx.233	FDW 08	2,5	0,2	1,6		3xM4	3
SF xx xxx 313	8/2F31/2xx.423	FDW 13	5	0,3	2,0	8,8	3xM6	10
SF xx xxx 384	4F38/2xx.433	FDW 13	8	0,3	2,0	8,8	3xM6	10
SF xx xxx 423	8/2F42/2xx.433	FDW 13	8	0,3	2,0		3xM6	10
SF xx xxx 484	4F48/2xx.443	FDW 13	13	0,3	1,2	9,6	3xM6	10
SF xx xxx 523	8/2F52/2xx.523	FDW 15	13	0,3	2,0	10,8	3xM6	10

Replacement and repairs may only be carried out by qualified personnel!

3 SF travel drive

3.3 Maintenance work

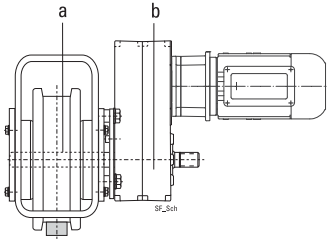

3.3.4 Gear

The gear has a long service life. All bearing points have roller bearings. The gearing is hardened, hard-machined and has high safety factors.

- During annual maintenance, check whether any oil has leaked (puddle of oil underneath the gear, drops of oil on the gearbox). If any loss of oil is ascertained, the oil must be changed and repairs scheduled if necessary.
- Note any gear noises from the crane when under load and without load. Rough, noisy running, knocking sounds indicate possible faults.
- If any faults are detected, repairs must be scheduled.
- If there is any uncertainty, a fresh diagnosis can be made after consulting experts, e.g. from the manufacturer (see back cover).

3.3.5 Changing grease/oil of travel drive

Lubricating toothed boss of wheel

The SF 1. .. travel drives have a gear with grease lubrication, the SF 25., SF 35.. with oil lubrication.

The toothed boss (a) is lubricated with grease (see table).

Run gear oil off while warm.

The type and quantity of oil or grease can be seen from the table.

Position of lubrication point		Type of lubricant	Designation	Quantity	Characteristics, makes	Order. No.
a	Toothed boss of wheel	Grease	KPF 1K	50 gr	Soap base: Lithium + MoS2 Dripping point: approx. 185°C (180°C) Penetration: 310-340 (310-340) Operating temperature: -20°to +120°C, (-50° to +150°C), e.g.: Aral Fett P 64037*, Aralub PMD1, BP Multi-purpose Grease L21M, Esso Multi-purpose Grease M, Mobil Grease Special, Shell Retimax AM *1, Texaco Molytex Grease EP2, Fuchs Renolit FLM2, (Fuchs Renolit FLM2)	
b	SF 1. 1.. SF 1. 2.. SF 1. 2..	Grease	KPF 0K-20	100 gr 200 gr 600 gr *2	Soap base: Lithium + MoS2 Dripping point: ca. +180°C Penetration: 355-385 Operating temperature: -30°to +130°C e.g.: Aral Grease P64037*, Aralub PMD0, Tribol Molub-Aloy Multi-purpose grease	32 250 09 65 0 (0.75 kg)
	Gear SF 25.. Gear SF 35.. Gear SA-. 5.. Gear SA-. 6..	Oil	CLP 460	1000 ml 1500 ml 1000 ml 3000 ml	Viscosity: 460 cSt/40°C (240 cSt/40°C) Pourpoint: -20°C (-40°) Flash point: +265°C (+270°C) e.g.: Fuchs Renep Compound 110*, Aral Degol BG 460, BP Energol GR-XP 460, Esso Spartan EP 460, Mobil Gear 634, Shell Omala Oel 460, Texaco Meropa 460, (Shell Tivela Oil 82)	32 250 07 65 0 (1 kg)

() = Lubricants for low operating temperatures,max. -30°C

* Factory filling

*1 Only down to -20°C

*2 Mounting position "motor at bottom"

3 SF travel drive

3.4 Motor data

SF ..	50 Hz
--------------	--------------

Index No.	Type	P	n1	TN	TA	TH	TB	Jrot	Jschw	cos φ N	cos φ K	DC	Ac T3	Wmax	PB
		kW	1/min	Nm	Nm	Nm	Nm	kgm ²	kgm ²			%		J/br	W
123	8/2F12/220.223	0,09 0,36	590 2420	1,46	3,8 3,6	2,3 2,3	1,3	0,0005	0,0053	0,55 0,83	0,77 0,93	20 40	800	3000	54
133	8/2F13/220.233	0,13 0,55	600 2540	2,07	5,1 5,1	3,5 3,5	2,5	0,0007	0,0085	0,55 0,82	0,72 0,92	20 40	500	3000	54
313	8/2F31/210.423	0,32 1,25	660 2550	4,68	7,6 10,5	6,4 6,8	5,0	0,0032	0,0165	0,69 0,88	0,89 0,90	20 40	600	12000	84
423	8/2F42/210.433	0,50 2,00	665 2680	7,13	12,0 17,4	9,2 10,4	8,0	0,0057	0,0267	0,74 0,95	0,87 0,90	20 40	360	12000	84
523	8/2F52/210.523	0,80 3,20	610 2550	11,96	21,0 24,0	18,0 18,0	13,0	0,0104	0,0408	0,74 0,96	0,83 0,82	20 40	300	25000	100

Index No.	Type	In			Ik		
		220...240V	380...415V	480...525V	220...240V	380...415V	480...525V
		[A]	[A]	[A]	[A]	[A]	[A]
123	8/2F12/220.223	1,7	1,0	0,8	2,4	1,4	1,1
		2,3	1,3	1,0	5,6	3,2	2,6
133	8/2F13/220.233	2,1	1,2	1,0	2,8	1,6	1,1
		2,8	1,6	1,3	7,6	4,5	2,6
313	8/2F31/210.423	2,4	1,4	1,1	5,0	2,9	2,3
		5,2	3,0	2,4	16,0	9,2	7,4
423	8/2F42/220.433	3,1	1,8	1,4	7,7	4,4	3,5
		7,0	4,0	3,2	28,0	16,0	13,0
523	8/2F52/210.223	4,7	2,7	2,2	10,6	6,1	4,9
		12,7	7,3	5,6	43,0	25,0	20,0

SF ..	400 V, 60 Hz
--------------	---------------------

Index No.	Type	P	n1	TN	TA	TH	TB	Jrot	Jschw	cos φ N	cos φ K	DC	Ac T3	Wmax	PB
		kW	1/min	Nm	Nm	Nm	Nm	kgm ²	kgm ²			%		J/br	W
123	8/2F12/220.223	0,09 0,36	590 2420	1,46	3,8 3,6	2,3 2,3	1,3	0,0005	0,0053	0,55 0,83	0,77 0,93	20 40	800	3000	54
133	8/2F13/220.233	0,13 0,55	600 2540	2,07	5,1 5,1	3,5 3,5	2,5	0,0007	0,0085	0,55 0,82	0,72 0,92	20 40	500	3000	54
313	8/2F31/210.423	0,32 1,25	660 2550	4,68	7,6 10,5	6,4 6,8	5,0	0,0032	0,0165	0,69 0,88	0,89 0,90	20 40	600	12000	84
423	8/2F42/210.433	0,50 2,00	665 2680	7,13	12,0 17,4	9,2 10,4	8,0	0,0057	0,0267	0,74 0,95	0,87 0,90	20 40	360	12000	84
523	8/2F52/210.523	0,80 3,20	610 2550	11,96	21,0 24,0	18,0 18,0	13,0	0,0104	0,0408	0,74 0,96	0,83 0,82	20 40	300	25000	100

Index No.	Type	In			Ik		
		220...240V	380...415V	480...525V	220...240V	380...415V	480...525V
		[A]	[A]	[A]	[A]	[A]	[A]
123	8/2F12/220.223	1,2	1,0	0,8	1,6	1,4	1,1
		1,5	1,3	1,0	3,7	3,2	2,6
133	8/2F13/220.233	1,47	1,2	1,0	1,8	1,6	1,3
		1,8	1,6	1,3	5,2	4,5	3,6
313	8/2F31/210.423	1,6	1,4	1,1	3,3	2,9	2,3
		3,5	3,0	2,4	10,6	9,2	7,4
423	8/2F42/220.433	2,1	1,8	1,4	5,1	4,4	3,5
		4,6	4,0	3,2	19,	16,0	13,0
523	8/2F52/210.223	3,1	2,7	2,2	7,0	6,1	4,1
		8,4	7,3	5,8	28,0	25,0	16,7

3 SF travel drive

3.4 Motor data (continued)



Index No.	Type	fN		P		n1		TN	TA	TH	TB	Jrot	IN		IK	cos φ N	cos φ K	DC	Ac	x
		*Y	*Δ	*Y	*Δ	*Δ	*Δ						Y	Δ						
		Hz		kw		1/min	Nm						A							
184	4F18/220.233 4F18/231.233	50	100	0,38	0,75	1220	2440	2,94	5,1	3,8	1,3	0,0005	1,1	2,2	2,7	0,73	0,82	60	500	34,1
384	4F38/210.233 4F38/221.233	50	100	1,1	2,20	1370	2740	7,7	17	13	8	0,0032	2,8	5,2	9,5	0,8	0,87	60	320	5,6
484	4F48/210.233 4F48/220.233	50	100	1,60	3,20	1425	2850	10,7	31	34	13	0,0057	4,3	8,6	23	0,71	0,83	60	300	2,6

Ac	[(c:h) x s]	Switching frequency factor	n1	[1/min]	Motor r.p.m.
cos φ K		Power factor (short circuit)	PB	[W]	Coil output (brake)
cos φ N		Power factor (nominal)	P	[kW]	Motor output
DC	[%]	Duty cycle	TA	[Nm]	Motor starting torque
IK	[A]	Short circuit current	TB	[Nm]	Braking torque (motor shaft)
IN	[A]	Rated current	TH	[Nm]	Run-up torque (motor shaft)
Jrot	[kgm2]	Moment of inertia, rotor	TN	[Nm]	Rated motor torque
Jschw	[kgm2]	Moment of inertia, centrifugal mass	Wmax	[J/Br]	Max. permissible friction energy (brake)
Jges	[kgm2]	Moment of inertia of motor as a whole	*1 x =		Terminal resistance

3 SF travel drive

3.5 Sound pressure level

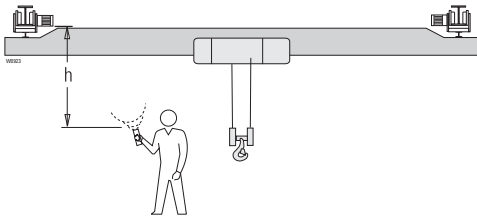

Measured at a distance of 1 m from the crane contour.

The mean sound pressure level calculated for one operating cycle (50% with nominal load, 50% without load) can be seen in the tables.

Instead of stating an emission value based on a workplace, the values from the tables at measuring distance "h" can be used.

Indoors

Type of travel drive	[db (A)] +/- 3				
	h [m]				
	1 m	2 m	4 m	8 m	16 m
SF .. 2.. ...	72	69	66	66	63
SF .. 8.. ...	78	75	72	69	66

Outdoors

Type of travel drive	[db (A)] +/- 3				
	h [m]				
	1 m	2 m	4 m	8 m	16 m
SF .. 2.. ...	72	66	60	54	48
SF .. 8.. ...	78	72	66	60	54

3.6 Conditions of use

The components are designed for use in industry and for the ambient conditions usual in industry.

Special measures must be taken for particular applications such as e.g. high degree of chemical pollution, outdoor use, offshore application, etc.

The manufacturer will be pleased to advise you.

Protection against dust and humidity in acc. with EN 60 529 / IEC

Standard: IP 55

Option: IP66

Permissible ambient temperatures

Standard: -20°C ... +40°C

Option: +60°

Frequency inverters can be used from -20°C to +50°C (non-dewing).

3 SF travel drive

3.7 Wearing parts

Brake disc (brake rotor)

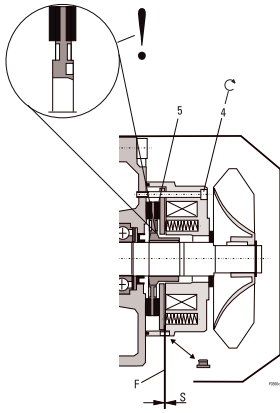

Travel drive	Motor	Order No. Brake disc
SF xx xxx 123	8/2F12/2xx.223	21 270 23 65 0
SF xx xxx 133	8/2F13/2xx.233	21 270 23 65 0
SF xx xxx 184	4F18/2xx.233	21 270 23 65 0
SF xx xxx 313	8/2F31/2xx.423	21 270 36 65 0
SF xx xxx 384	4F38/2xx.423	21 270 36 65 0
SF xx xxx 423	8/2F42/2xx.433	21 270 36 65 0
SF xx xxx 484	4F48/2xx.443	21 270 36 65 0
SF xx xxx 523	8/2F52/2xx.523	21 270 42 65 0

Replacement and repairs may only be carried out by qualified personnel.

4 SA-C travel drive

4.1 Installation

4.1.1 Description

The travel drives are high-quality drives with smooth starting and braking characteristics as is required in particular for material handling.

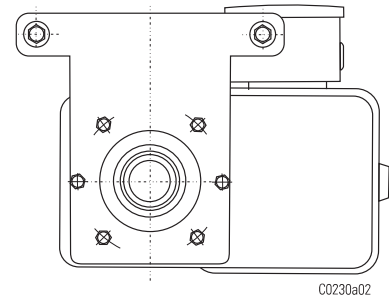
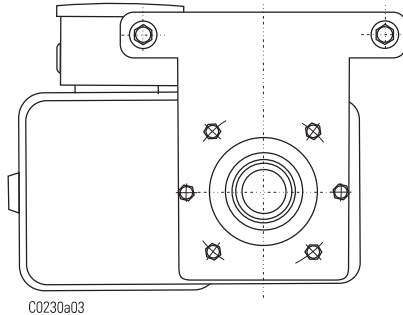
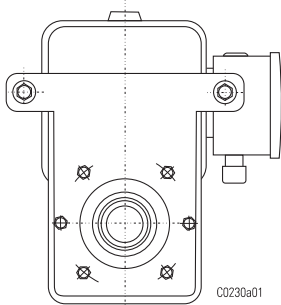

4.1.2 Permissible mounting position

- The travel drive can be rotated around its main horizontal axis in 90° steps.
- The gear vent plug must always be at the highest point of the gear
- Remove sticker from vent plug.
- Tighten fixing bolts with specified torque
- Check oil level before commissioning

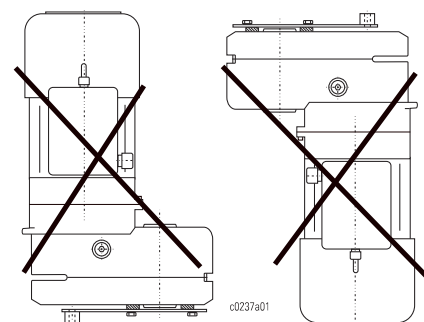
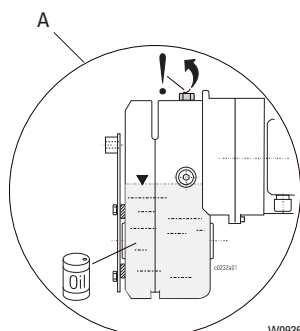
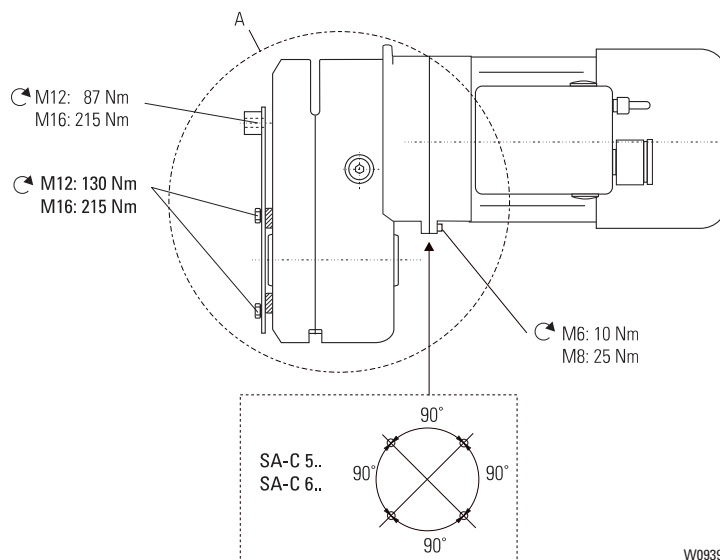

4 SA-C travel drive

4.1 Installation (continued)



4.1.3 Electrical connection

- The mains voltage must match that given on the rating plate.
- Electrical connection with plug connection or cable gland.
- If using cable gland, follow the terminal diagram.

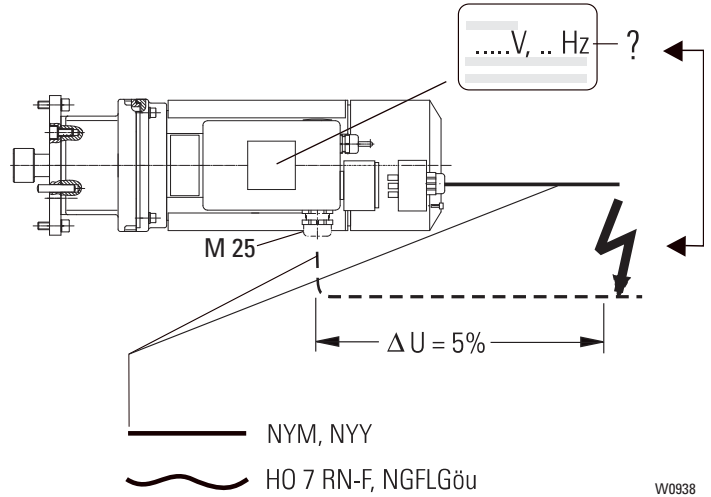

W0938

Block terminal diagram

8/2 F. motor

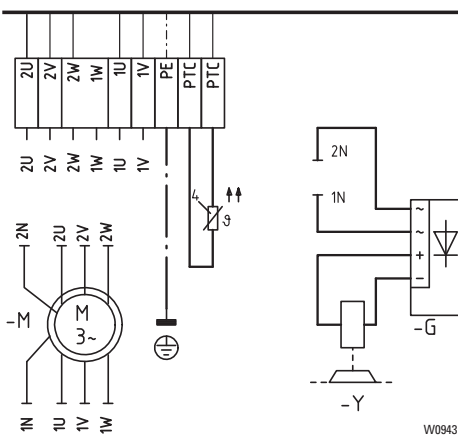

4 F. motor

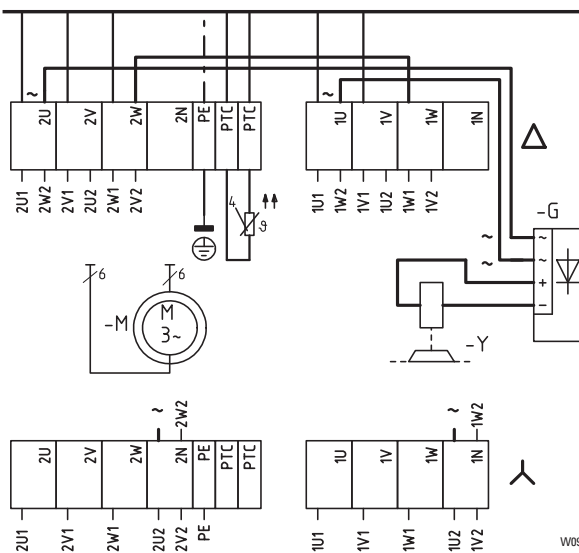
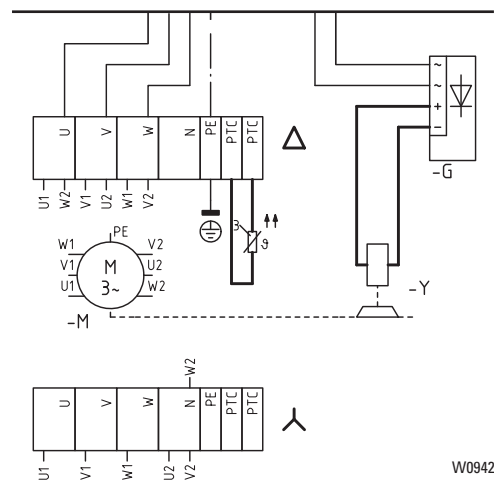

Standard settings for frequency inverter

Speed m/min	8	10	12,5	16	20	25	32	40	50	63	80	100
Max. frequency Hz	80	100	50	63	80	100	80	100	80	100	100	100
Motor connection	Δ	Δ	Y	Y	Δ	Δ	Δ	Δ	Δ	Δ	Δ	Δ
Run-up time [s]	2,1	2,4	2,8	3,3	3,8	4,2	4,7	5,2	5,6	6,0	6,7	8,4
Stopping time [s]	1,7	2,0	2,3	2,7	3,0	3,4	3,8	4,2	4,5	4,8	5,4	6,7

4 SA-C travel drive

4.2 Maintenance



This section deals with the operational reliability, availability, and maintaining the value of your travel drives. Although they are practically maintenance-free, the components subject to wear must be inspected regularly. This is required by the accident prevention regulations. The inspections must be performed by **qualified personnel**, see page 2.

General information on inspection and maintenance

- Maintenance and repair work may only be carried out when the crane is not under load.
- Switch off and padlock main isolator.
- Follow the accident prevention regulations.

Please also note the "Safety instructions" on page 5.
Wearing parts, see page 30.

4.3 Maintenance work

4.3.1

No.	Inspection on commissioning*1	Daily inspection on starting work *2	Periodic inspections every 12 months *3	Periodic maintenance every 12 months *2	Maintenance after 10 years or general overhaul *4	Inspection and maintenance table (Classification: 1 Bm)	See page
1			•			Attachment of travel drive, torque support	22
2	•	•	•			Check braking effect of travel drive	
3	•					Oil level	26
4					•	Change gear oil/grease of travel drive	26

*1 By a fitter engaged by the manufacturer

*2 By the operator

*3 Periodic maintenance every 12 months, possibly earlier if so prescribed by national regulations, to be performed by a fitter engaged by the manufacturer.
Similarly, heavy-duty applications and adverse conditions (dirt, solvents, multi-shift operation etc.) necessitate shortening this inspection and maintenance interval.

*4 In manufacturer's works.

4 SA-C travel drive

4.3 Maintenance work (continued)

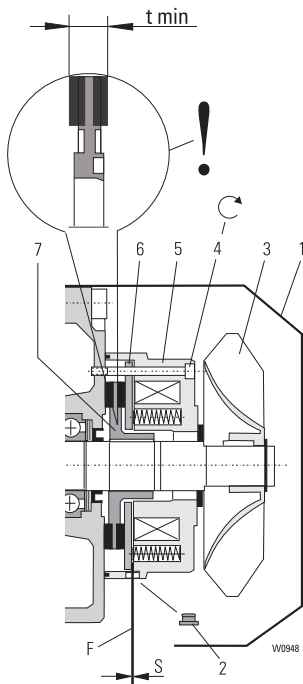

4.3.2 Travel motor brake

Check brake at regular intervals. The intervals must be adapted in accordance with the application.

- Move carriage into a safe position
- Remove fan cover (1)
- Remove plug (2)
- Measure air gap (S) with feeler gauge (F). See table for max. permissible air gap (S).
- The travel motor brake needs no adjustment.
- If the max. permissible air gap (S) has been reached, the brake disc (brake rotor) must be replaced.

3.3.3 Replacing brake disc (brake rotor)

- Remove fan cover (1)
- Pull off fanwheel (3), remove feather key
- Disconnect brake
- Unscrew fixing screws (4)
- Remove magnet piece (5) together with armature disc (6)
- Remove brake disc (brake rotor) (7)

Replace in reverse order. Ensure that the check hole for measuring the air gap is underneath.

Travel drive	Motor type	Brake	Braking torque [Nm]	S min. [mm]	S max. [mm]	t min [mm]	(4)	↻ Nm
SA-C ... 133	8/2F13/2xx.233	FDW 08	2,5	0,2	1,6	6,1	3xM4	3
SA-C ... 184	4F18/2xx.233	FDW 08	2,5	0,2	1,6		3xM4	3
SA-C ... 313	8/2F31/2xx.423	FDW 13	5	0,3	2,0	8,8	3xM6	10
SA-C ... 384	4F38/2xx.433	FDW 13	8	0,3	2,0	8,8	3xM6	10
SA-C ... 423	8/2F42/2xx.433	FDW 13	8	0,3	2,0		3xM6	10
SA-C ... 484	4F48/2xx.443	FDW 13	13	0,3	1,2	9,6	3xM6	10
SA-C ... 523	8/2F52/2xx.523	FDW 15	13	0,3	2,0	10,8	3xM6	10

Replacement and repairs may only be carried out by qualified personnel!

4 SA-C travel drive

4.3 Maintenance work

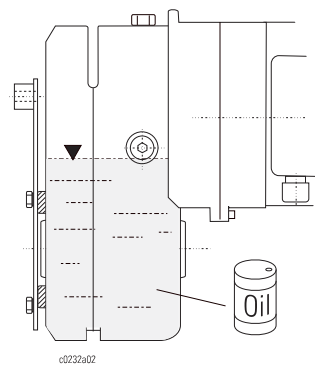
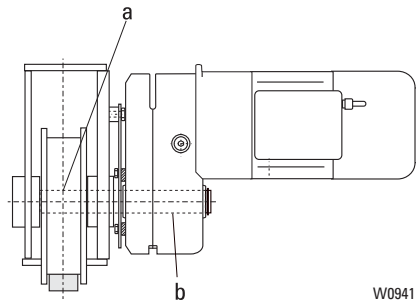

4.3.4 Gear

The gear has a long service life. All bearing points have roller bearings. The gearing is hardened, hard-machined and has high safety factors.

- During annual maintenance, check whether any oil has leaked (puddle of oil underneath the gear, drops of oil on the gearbox). If any loss of oil is ascertained, the oil must be changed and repairs scheduled if necessary.
- Note any gear noises from the crane when under load and without load. Rough, noisy running, knocking sounds indicate possible faults.
- If any faults are detected, repairs must be scheduled.
- If there is any uncertainty, a fresh diagnosis can be made after consulting experts, e.g. from the manufacturer (see back cover).

4.3.5 Changing oil of travel drive Lubricating toothed boss of wheel

The SA-C .. travel drives have a gear with oil lubrication. The toothed boss of the wheel (a) and the gear (b) is lubricated with grease (see table).

Run gear oil off while warm.

The type and quantity of oil or grease can be seen from the table.

Position of lubrication point		Type of lubricant	Designation	Quantity	Charakteristics, makes	Order. No.
a	Toothed boss of wheel	Grease	KPF 1K	50 gr	Soap base: Lithium + MoS2 Dripping point: approx. 185°C (180°C) Penetration: 310-340 (310-340) Operating temperature: -20°to +120°C, (-50° to +150°C), e.g.: Aral Fett P 64037*, Aralub PMD1, BP Multi-purpose Grease L21M, Esso Multi-purpose Grease M, Mobil Grease Special, Shell Retimax AM *1, Texaco Molytex Grease EP2, Fuchs Renolit FLM2, (Fuchs Renolit FLM2)	
b	Toothed boss of gear					
	Gear SA-. 5.. Gear SA-. 6..	Oil	CLP 460	1000 ml 1500 ml 1000 ml 3000 ml	Viscosity: 460 cSt/40°C (240 cSt/40°C) Pourpoint: -20°C (-40°) Flash point: +265°C (+270°C) e.g.: Fuchs Renep Compound 110*, Aral Degol BG 460, BP Energol GR-XP 460, Esso Spartan EP 460, Mobil Gear 634, Shell Omala Oel 460, Texaco Meropa 460, (Shell Tivela Oil 82)	32 250 07 65 0 (1 kg)

() = Lubricants for low operating temperatures, max. -30°C

* Factory filling

*1 Only down to -20°C

4 SA-C travel drive

4.4 Motor data

SA-C ..	50 Hz
----------------	--------------

Index No.	Type	P	n1	TN	TA	TH	TB	Jrot	Jschw	cos φ N	cos φ K	DC	Ac T3	Wmax	PB
		kW	1/min	Nm	Nm	Nm	Nm	kgm ²	kgm ²			%		J/br	W
123	8/2F12/220.223	0,09 0,36	590 2420	1,46	3,8 3,6	2,3 2,3	1,3	0,0005	0,0053	0,55 0,83	0,77 0,93	20 40	800	3000	54
133	8/2F13/220.233	0,13 0,55	600 2540	2,07	5,1 5,1	3,5 3,5	2,5	0,0007	0,0085	0,55 0,82	0,72 0,92	20 40	500	3000	54
313	8/2F31/210.423	0,32 1,25	660 2550	4,68	7,6 10,5	6,4 6,8	5,0	0,0032	0,0165	0,69 0,88	0,89 0,90	20 40	600	12000	84
423	8/2F42/210.433	0,50 2,00	665 2680	7,13	12,0 17,4	9,2 10,4	8,0	0,0057	0,0267	0,74 0,95	0,87 0,90	20 40	360	12000	84
523	8/2F52/210.523	0,80 3,20	610 2550	11,96	21,0 24,0	18,0 18,0	13,0	0,0104	0,0408	0,74 0,96	0,83 0,82	20 40	300	25000	100

Index No.	Type	In			Ik		
		220...240V	380...415V	480...525V	220...240V	380...415V	480...525V
		[A]	[A]	[A]	[A]	[A]	[A]
123	8/2F12/220.223	1,7	1,0	0,8	2,4	1,4	1,1
		2,3	1,3	1,0	5,6	3,2	2,6
133	8/2F13/220.233	2,1	1,2	1,0	2,8	1,6	1,1
		2,8	1,6	1,3	7,6	4,5	2,6
313	8/2F31/210.423	2,4	1,4	1,1	5,0	2,9	2,3
		5,2	3,0	2,4	16,0	9,2	7,4
423	8/2F42/220.433	3,1	1,8	1,4	7,7	4,4	3,5
		7,0	4,0	3,2	28,0	16,0	13,0
523	8/2F52/210.223	4,7	2,7	2,2	10,6	6,1	4,9
		12,7	7,3	5,6	43,0	25,0	20,0

SA-C ..	60 Hz
----------------	--------------

Index No.	Type	P	n1	TN	TA	TH	TB	Jrot	Jschw	cos φ N	cos φ K	DC	Ac T3	Wmax	PB
		kW	1/min	Nm	Nm	Nm	Nm	kgm ²	kgm ²			%		J/br	W
123	8/2F12/220.223	0,11 0,44	710 2900	1,46	3,8 3,6	2,3 2,3	1,3	0,0005	0,0053	0,55 0,83	0,77 0,89	20 40	800	3000	54
133	8/2F13/220.233	0,16 0,66	720 3050	2,07	5,1 5,1	3,5 3,5	2,5	0,0007	0,0085	0,55 0,82	0,72 0,92	20 40	500	3000	54
313	8/2F31/210.423	0,36 1,50	790 3060	4,68	7,6 10,5	6,4 6,8	5,0	0,0032	0,0165	0,69 0,86	0,89 0,90	20 40	600	12000	84
423	8/2F42/210.433	0,60 2,40	800 3220	7,13	12,0 17,4	9,2 10,4	8,0	0,0057	0,0267	0,74 0,95	0,87 0,90	20 40	360	12000	84
523	8/2F52/210.523	0,90 3,80	730 3060	11,96	21,0 24,0	18,0 18,0	13	0,0104	0,0408	0,74 0,96	0,83 0,82	20 40	300	25000	100

Index No.	Type	In			Ik		
		220...240V	380...415V	480...525V	220...240V	380...415V	480...525V
		[A]	[A]	[A]	[A]	[A]	[A]
123	8/2F12/220.223	1,2	1,0	0,8	1,6	1,4	1,1
		1,5	1,3	1,0	3,7	3,2	2,6
133	8/2F13/220.233	1,47	1,2	1,0	1,8	1,6	1,3
		1,8	1,6	1,3	5,2	4,5	3,6
313	8/2F31/210.423	1,6	1,4	1,1	3,3	2,9	2,3
		3,5	3,0	2,4	10,6	9,2	7,4
423	8/2F42/220.433	2,1	1,8	1,4	5,1	4,4	3,5
		4,6	4,0	3,2	19,	16,0	13,0
523	8/2F52/210.223	3,1	2,7	2,2	7,0	6,1	4,1
		8,4	7,3	5,8	28,0	25,0	16,7

4 SA-C travel drive

4.4 Motor data (continued)



Index No.	Type	fN		P		n1		TN	TA	TH	TB	Jrot	IN		IK	cos φ	cos φ	DC	Ac	x
		*Y	*Δ	*Y	*Δ	*Δ	*Δ						Y	Δ		N	K			
		Hz	kw	1/min	Nm	Nm	Nm						A	A		%	Ω			
184	4F18/220.233 4F18/231.233	50	100	0,38	0,75	1220	2440	2,94	5,1	3,8	1,3	0,0005	1,1	2,2	2,7	0,73	0,82	60	500	34,1
384	4F38/210.233 4F38/221.233	50	100	1,1	2,20	1370	2740	7,7	17	13	8	0,0032	2,6	5,2	9,5	0,8	0,87	60	320	5,6
484	4F48/210.233 4F48/220.233	50	100	1,60	3,20	1425	2850	10,7	31	34	13	0,0057	4,3	8,6	23	0,71	0,83	60	300	2,6

Ac	[(c:h) x s]	Switching frequency factor	n1	[1/min]	Motor r.p.m.
cos φ K		Power factor (short circuit)	PB	[W]	Coil output (brake)
cos φ N		Power factor (nominal)	P	[kW]	Motor output
DC	[%]	Duty cycle	TA	[Nm]	Motor starting torque
IK	[A]	Short circuit current	TB	[Nm]	Braking torque (motor shaft)
IN	[A]	Rated current	TH	[Nm]	Run-up torque (motor shaft)
Jrot	[kgm ²]	Moment of inertia, rotor	TN	[Nm]	Rated motor torque
Jschw	[kgm ²]	Moment of inertia, centrifugal mass	Wmax	[J/Br]	Max. permissible friction energy (brake)
Jges	[kgm ²]	Moment of inertia of motor as a whole	*1 x =		Terminal resistance

4 SA-C travel drive

4.5 Sound pressure level

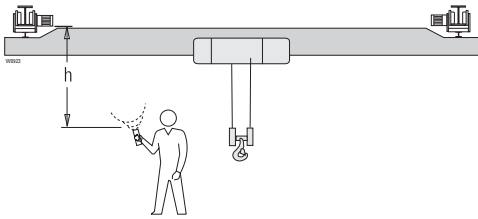

Measured at a distance of 1 m from the crane contour.

The mean sound pressure level calculated for one operating cycle (50% with nominal load, 50% without load) can be seen in the tables.

Instead of stating an emission value based on a workplace, the values from the tables at measuring distance "h" can be used.

Indoors

Type of travel drive	[db (A)] +/- 3				
	h [m]				
	1 m	2 m	4 m	8 m	16 m
SA-C ..	72	69	66	66	63

Outdoors

Type of travel drive	[db (A)] +/- 3				
	h [m]				
	1 m	2 m	4 m	8 m	16 m
SA-C ..	72	66	60	54	48

4.6 Conditions of use

The components are designed for use in industry and for the ambient conditions usual in industry.

Special measures must be taken for particular applications such as e.g. high degree of chemical pollution, outdoor use, offshore application, etc.

The manufacturer will be pleased to advise you.

Protection against dust and humidity in acc. with EN 60 529 / IEC

Standard: IP 55

Option: IP66

Permissible ambient temperatures

Standard: -20°C ... +40°C

Option: +60°

Frequency inverters can be used from -20°C to +50°C (non-dewing).

4 SA-C travel drive

4.7 Wearing parts

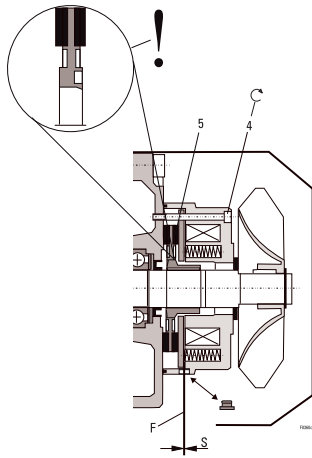

Brake disc (brake rotor)

Travel drive	Motor	Order no. Brake disc
SA-C ... 133	8/2F13/2xx.233	21 270 23 65 0
SA-C ... 184	4F18/2xx.233	21 270 23 65 0
SA-C ... 313	8/2F31/2xx.423	21 270 36 65 0
SA-C ... 384	4F38/2xx.423	21 270 36 65 0
SA-C ... 423	8/2F42/2xx.433	21 270 36 65 0
SA-C ... 484	4F48/2xx.443	21 270 36 65 0
SA-C ... 523	8/2F52/2xx.523	21 270 42 65 0

Replacement and repairs may only be carried out by qualified personnel.

5 General information

5.1 Seminars

We offer seminars covering all main product groups, such as seminars for crane operators, wire rope hoist seminar, chain hoist seminar, seminar on load suspension equipment and seminar for material conveying equipment.

However we would be please to offer a special programme orientated on your individual specifications and requirements.

The seminars are individual modules or can form part of a long-term training course; they are held in German or English.

Each seminar is concluded with a certificate.

You can obtain information on our seminar programme from:

STAHL CraneSystems GmbH
Daimlerstraße 6 | D-74653 Künzelsau | Tel. +49 7940 128-0
marketing@stahlcranes.com

Or you can find information at →www.stahlcranes.com

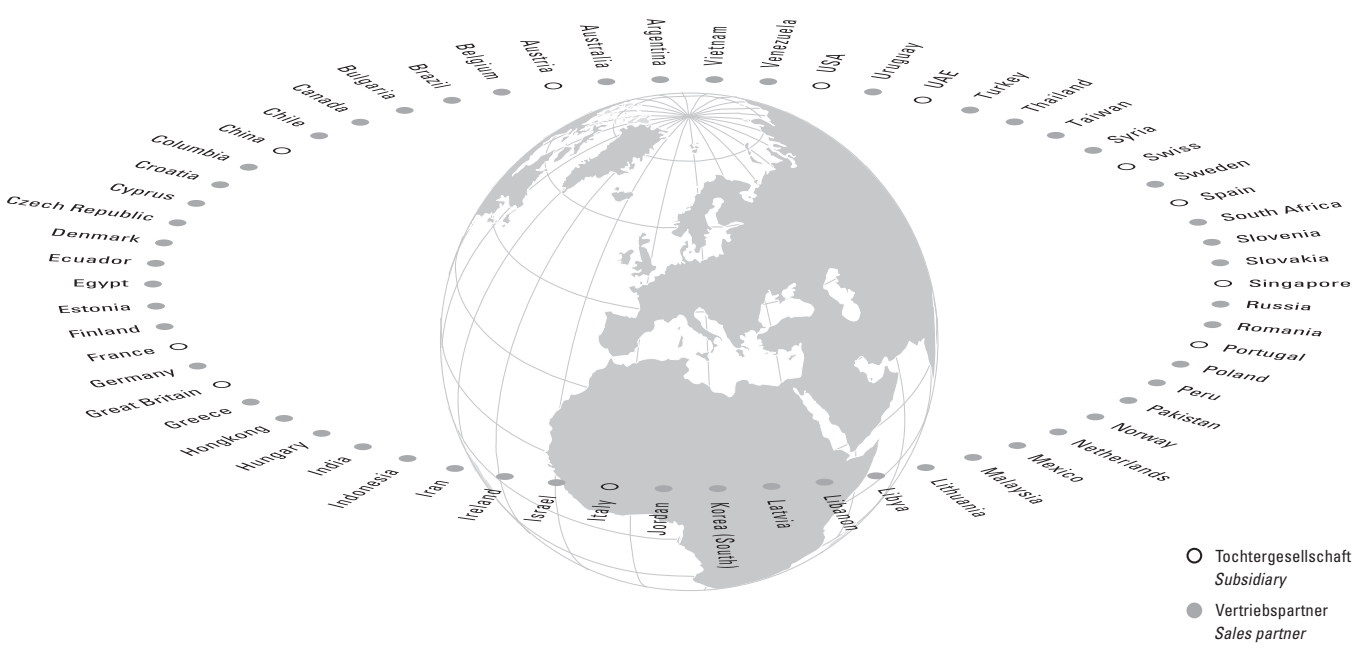

○ Tochtergesellschaft
Subsidiary
● Vertriebspartner
Sales partner

○ **Tochtergesellschaft/Subsidiary**

Austria
Steyregg
Tel +43 732 641111-0
Fax +43 732 641111-33
office@stahlcranes.at

Great Britain
Birmingham
Tel +44 121 7676400
Fax +44 121 7676485
info@stahlcranes.co.uk

Portugal
Lissabon
Tel +351 21 44471-60
Fax +351 21 44471-69
ferrometal@ferrometal.pt

Switzerland
Däniken
Tel +41 62 82513-80
Fax +41 62 82513-81
info@stahlcranes.ch

China
Shanghai
Tel +86 21 6257 2211
Fax +86 21 6254 1907
service_cn@stahlcranes.cn

India
Chennai
Tel +91 44 4352-3955
Fax +91 44 4352-3957
indiasales@stahlcranes.in

Singapore
Singapore
Tel +65 6271 2220
Fax +65 6377 1555
sales@stahlcranes.sg

United Arab Emirates
Dubai
Tel +971 4 805-3700
Fax +971 4 805-3701
info@stahlcranes.ae

France
Paris
Tel +33 1 39985060
Fax +33 1 34111818
info@stahlcranes.fr

Italy
S. Colombano
Tel +39 0185 358391
Fax +39 0185 358219
info@stahlcranes.it

Spain
Madrid
Tel +34 91 484-0865
Fax +34 91 490-5143
info@stahlcranes.es

USA
Charleston, SC
Tel +1 843 767-1951
Fax +1 843 767-4366
sales@stahlcranes.us

● **Vertriebspartner/Sales partner**

Die Adressen von über 100 Vertriebspartnern weltweit finden Sie im Internet auf www.stahlcranes.com unter Kontakt.
You will find the addresses of over 100 sales partners on the Internet at www.stahlcranes.com under Contact.

➔ www.stahlcranes.com

STAHL CraneSystems GmbH, Daimlerstr. 6, 74653 Künzelsau, Germany
Tel +49 7940 128-0, Fax +49 7940 55665, marketing@stahlcranes.com

