



---

**Chain hoists\_**  
Operating and Maintenance Instructions

---

↘EN

---

## ***Fundamental information***

You have purchased a product manufactured by STAHL CraneSystems GmbH. This chain hoist has been constructed in compliance with the applicable standards and regulations.

### **Inspect hoist for damage caused in transit immediately upon delivery.**

Report damage caused in transit and after consulting the manufacturer/supplier repair or have repaired before installation and commissioning. Do not install or commission a damaged hoist!

- **Assembly**
- **installation**
- **commissioning**
- **tests**
- **maintenance and elimination of faults**

## **may only be carried out by a qualified person**

### **Terms employed**

#### **User**

Whoever uses and employs the chain hoist or has it operated by suitable trained personnel is considered to be the user (employer/company).

#### **Trained personnel**

Trained personnel are persons who have been instructed and trained in the duties with which they are entrusted and the risks which may arise from incorrect behaviour, have been advised on the necessary protective devices, precautions, applicable regulations, accident prevention regulations and prevailing conditions and have proven their ability.

#### **Skilled electrician**

A skilled electrician possesses knowledge and experience on electrical equipment arising from specialist training and, with knowledge of the applicable standards and regulations, is able to assess the work with which he is entrusted and detect and avoid possible risks.

#### **Definition of a qualified person:**

A qualified person is one with the necessary qualification, based on theoretical and practical knowledge of hoists, for the required activities as listed in the operating instructions.

The person must be in a position to assess the safety of the installation in conjunction with the application.

Persons with the authority to undertake certain maintenance work on our products include service engineers of manufacturer and trained fitters with the corresponding certification.

#### **Seminars:**

Comprehensive understanding of material handling products is a prerequisite for the correct use of equipment. Competent and practically oriented, we impart the specialist knowledge required for the correct use, monitoring and care of your installation. Ask for our seminar programme.

# Table of contents

---

<b>1 Safety instructions</b>	1.1 Symbols .....	4
	1.2 Operating instructions.....	4
	1.3 Use for intended purpose .....	5
	1.4 Safety-conscious operation.....	5
	1.5 Organisational safety precautions.....	6
	1.6 Electrical equipment.....	6
	1.7 Warranty.....	6
	1.8 Periodic tests.....	6
<b>2 Getting to know the chain hoist</b>	.....	7
<b>3 Installing</b>	3.1 Installing stationary chain hoist.....	8
	3.2 Installing trolley.....	8
	3.3 Installing trolley on chain hoist .....	9
	3.4 Connecting electric trolley.....	11
	3.5 Runway endstop .....	11
	3.7 Fitting the chain box .....	11
	3.8 Fitting the control pendant .....	12
	3.9 Checking screw connections .....	12
	3.10 Mains connection .....	12
	3.11 Dismantling .....	12
<b>4 Commissioning</b>	4.1 Checklist for commissioning .....	13
<b>5 Operating</b>	5.1 Duties of crane operator .....	14
	5.2 Operating control pendant.....	15
	5.3 Emergency stop .....	15
<b>6 Maintenance</b>	6.1 Maintenance work .....	16
	6.2 Maintenance intervals.....	16
	6.3 Hook .....	17
	6.4 Load chain.....	17
	6.5 Checking function of slipping clutch .....	18
	6.6 Adjusting slipping clutch .....	18
	6.7 Hoist motor brake .....	20
	6.8 Oil change .....	20
	6.9 Travel motor brake.....	21
	6.10 Oil change .....	21
	6.11 General overhaul .....	21
	6.12 Trolley.....	21
	6.13 Operating hours counter (optional) .....	21
<b>7 Repairs</b>	7.1 Chain drive .....	22
<b>8 Wearing parts</b>	8.1 Hoist .....	24
	8.2 Trolley.....	24
<b>9 Technical data</b>	9.1 Classification in acc. with FEM .....	25
	9.2 Ambient conditions.....	25
	9.3 Hoist motor data.....	26
	9.4 Travel motor data .....	27
	9.5 Specifications for mains connection.....	28
	9.6 Lubricants.....	30
	9.7 Sound level.....	31
	9.8 Chain certificate.....	31

Subject to alterations

# 1 Safety instructions

---

## 1.1 Symbols

In these operating instructions, the following symbols indicate particularly important information on risks and safety in operation.



### **Safety at work**

This symbol marks all information on safety at work where risks to life and limb are entailed.



### **Warning of electrical voltage**

Covers such as hoods and caps which are marked with this symbol may only be opened by "qualified persons or suitably instructed personnel".



### **Warning of suspended load**

It is forbidden for persons to stand under suspended loads. This entails risks to life and limb!



### **Safety in operation**

Information marked with this symbol must be observed to avoid damage to the chain hoist or the goods transported.

In these operating instructions, these symbols mark particularly important information on risks and safety in operation.

## 1.2 Operating instructions

Read carefully and follow the operating instructions

# 1 Safety instructions

## 1.3 Use for intended purpose



- Chain hoists are intended for lifting freely movable and guided loads that cannot tilt. Depending on their design, they are for stationary or mobile use. If loads are to be towed horizontally, or in the case of guided loads, automatic operation, continuous deadweight or constantly repeated hoisting motions, the individual application must be assessed. Contact the manufacturer in case of doubt.
- If the hoist forms "part of a machine," the person placing it on the market must ensure that the hoist meets the specific regulations of the application.
- Runways, suspensions and endstops must be of suitable dimensions.
- Do not carry out any alterations or modifications. Additional fitments must be authorised by the manufacturer. The declaration of conformity may be invalidated.
- Load chain hoist only up to the permissible safe working load, following the data on the rating plate. (**Caution: danger of load falling**)



### Not permitted are for example:

- Exceeding the safe working load
- Transporting persons
- Pulling loads at an angle
- Pulling loads loose, dragging or towing loads
- Manipulating the slipping clutch
- Operating the hoist with slack chain
- Touching the chain during the hoisting motion
- Operating a damaged hoist
- Operating the hoist with the chain twisted
- Approaching the emergency limit switch in normal operation
- Operating the chain hoist without a phase monitoring relay if the control provided by the customer is not installed in the terminal box on the chain hoist, but for example in a stationary control cabinet.

## 1.4 Safety-conscious operation



The ST chain hoists are constructed according to the state of the art and equipped with a slipping clutch as overload protection. In spite of this, dangers may arise from incorrect use or use for an unintended purpose.

- The operator, see page 2, is responsible for ensuring that work is carried out with safety in mind and avoiding risks. (EC directive 99/92/EC, Decree on Safety at Work)
- Read the operating instructions before starting to work with the chain hoist.
- Observe the "Duties of crane operator", see page 14.
- Before starting work, find out where the EMERGENCY STOP button is (usually in the control pendant).
- **Do not** place your hand between edges which may pinch or cut. See sketch
- Do not use the emergency limit switch (ultimate limit switch for highest and lowest hook position) as an operational limit switch.
- Report damage and defects to the chain hoist (abnormal noises, impaired braking function, deformations, ...) to the person responsible immediately. Do not use the chain hoist until the faults have been eliminated.
- Do not remove information plates from the chain hoist. Replace illegible or damaged plates.
- Have hoist inspected by the relevant authority before commissioning.

## 1.5 Organisational safety precautions



- Only direct persons to operate the hoist if they have been trained or instructed in its use. Observe the legal minimum age!
- At regular intervals, check that work is being carried out in a safety-conscious manner.
- Observe the intervals specified for periodic tests. File the test reports in the test logbook.
- Store the operating instructions within easy reach where the chain hoist is operated.

# 1 Safety instructions

---

## 1.6 Electrical equipment



Chain hoists, models ST05, ST10, ST20, ST30, ST32, ST50 and ST60, can be supplied with various versions of electrical equipment.

The chain hoist functions with dangerous electrical voltages.

- Disconnect the chain hoist before opening covers marked with this symbol.
- The chain hoist may only be opened by qualified personnel (see page 2) or personnel having been instructed.

### a) Direct control:

The motor of the chain hoist is switched on and off directly, i.e. without the use of contactors. Mains voltage and mains current are present in the control pendant. Due to the limited ampacity of the control pendants, direct control is only available up to 1.6 kW motor output at 400 V, 3 ph, 50 Hz. Direct control is not permissible in various countries (e.g. Canada, U.S.A.) due to legal stipulations and standards.

### b) Contactor control:

The motor of the chain hoist is switched by means of a contactor-transformer combination.

A safety extra-low voltage is present in the control pendant.

Contactor control is available for all motor sizes and outputs and is accepted worldwide. The control voltage generated by the transformer is selected corresponding to customer requirements and national standards. 48 V or 230 V control voltage is generally used in Europe, 120 V in North America.

### c) Version without control:

STAHL chain hoists are available without control. The switchgear (e.g. contactors and transformer) are then not supplied. The rectifier for activating the brake remains part of the supply.

Safety note: if the hoist is supplied without control, it is recommended that the customer install a phase monitoring relay. If the control is not installed in the terminal box on the chain hoist, but in a control cabinet for example, a phase monitoring relay is obligatory.

If the control is supplied by others, or work carried out on the control, the braking function must be tested.

## 1.7 Warranty

- The warranty will become invalid if these operating instructions are not observed for installation, operation, inspection and maintenance.
- Repairs and elimination of faults within the scope of the warranty may only be performed by qualified personnel (see page 2) after the manufacturer/supplier has been consulted and has given his approval.  
The warranty will become invalid if the hoist is modified or original spare parts not used.

## 1.8 Periodic tests



Hoists and cranes must be inspected by a **qualified person**, see page 2, at least once a year. The results of the test must be recorded and filed in the test log book. The remaining service life of the hoist acc. to FEM 9.755 must also be established during this inspection.

The periodic tests must be adapted to the hoist's use. Intensive use entails shorter maintenance intervals.

**All tests must be initiated by the user, see page 2.**

## 2 Getting to know the chain hoist

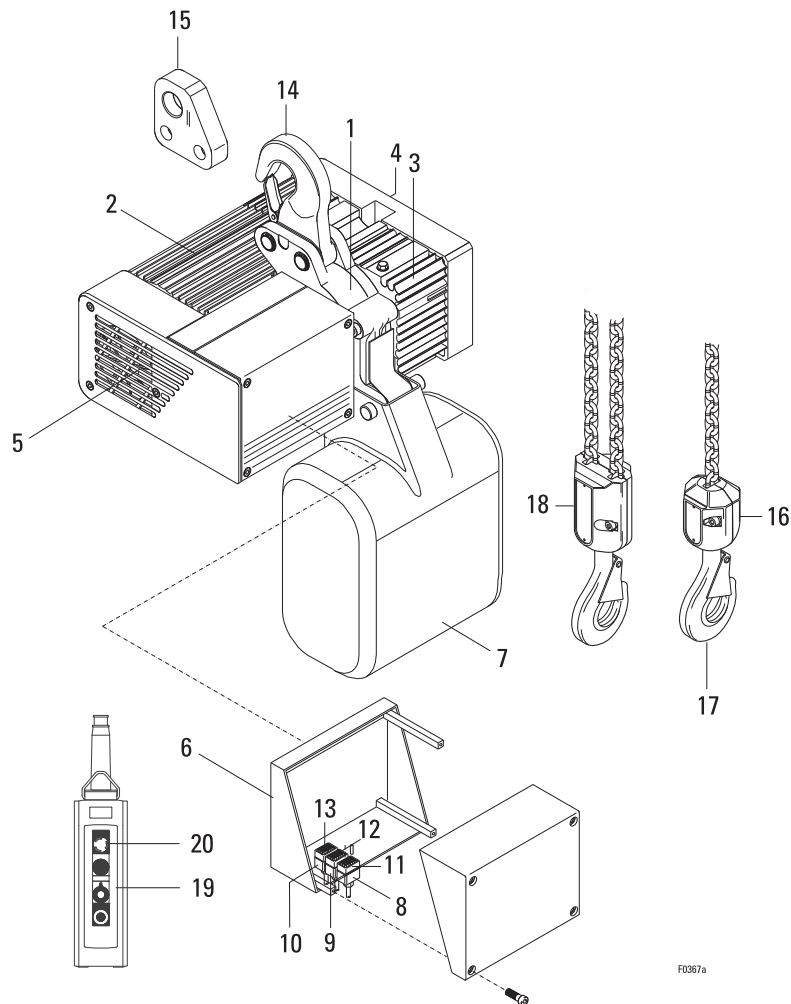

F0367a

- 1 Chain drive
- 2 Motor
- 3 Gear
- 4 Slipping clutch
- 5 Brake
- 6 Panel box
- 7 Chain box
- 8 Plug for control pendant
- 9 Plug for travel drive
- 10 Plug for mains connection
- 11 Socket for control pendant
- 12 Socket for travel drive
- 13 Socket for mains connection
- 14 Suspension hook
- 15 Suspension eye
- 16 Bottom hook block, single fall
- 17 Load hook
- 18 Bottom hook block, 2-fall
- 19 Control pendant
- 20 Emergency off

Some illustrations include options

### 3 Installation

#### 3.1 Installing stationary chain hoist

Note installation position of suspension eye or suspension hook ↑ sketch!  
(Tightening torque ST05 see page 12)

ST05

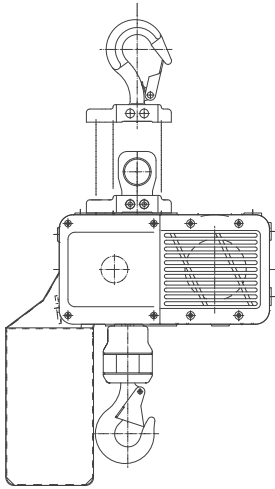

ST10 - ST60

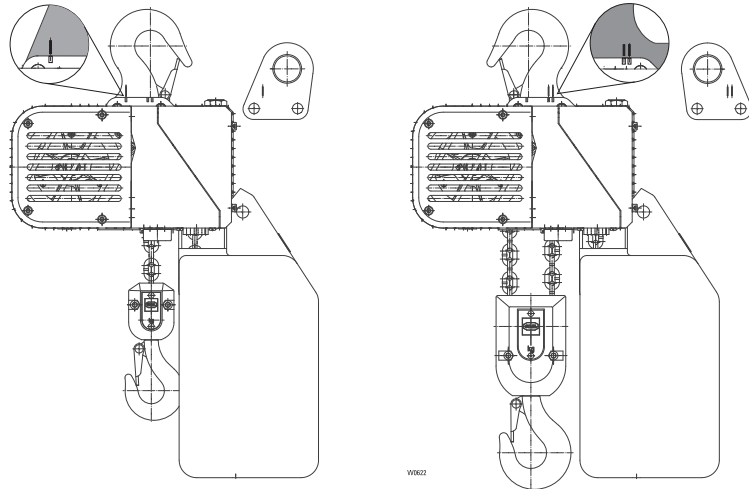

#### 3.2 Installing trolley

##### 3.2.1 Adjusting trolley to runway flange

1. Adjust play of wheel flanges, see sketch and table
2. Tighten nut with specified torque, see page 12
3. Fit screw retentions.

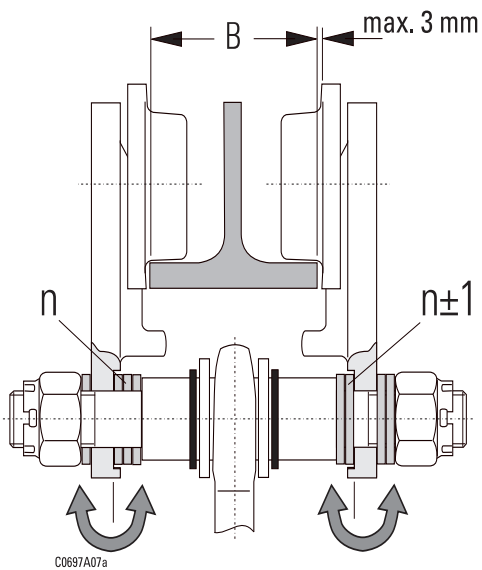

Suspend the chain hoist in the centre of the trolley.  
Grease wheel gearing.

Use only original spare parts for modifying the flange width.



## 3 Installation

### 3.3 Installing trolley on chain hoist

#### 1. US-G 10 with ST05

Always suspend chain hoist from centre of trolley. See sketch, page 8

#### US-G 10 with ST10

Fit suspension piece with suspension bolt (a) to chain hoist. Note installation position of suspension piece. Lock bolt (a) with washer (b) and cheese-head screw (c). See sketch

#### KFN 10/32 with ST10/ST20-ST32; ST50 /ST60 1/1

Fit suspension piece with suspension bolt (a) to chain hoist. Note installation position of suspension piece. Lock bolt (a) with locking plate (b) and cheese-head screw (c). See sketch

US-G10 with ST05 1/1 ... 2/1

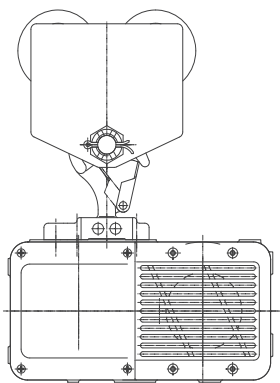

US-G10 with ST10 1/1

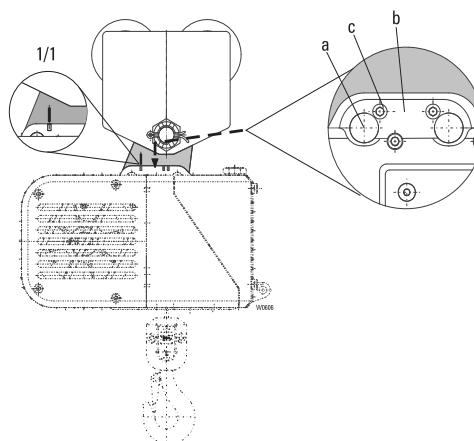

KFN10/32 1/1

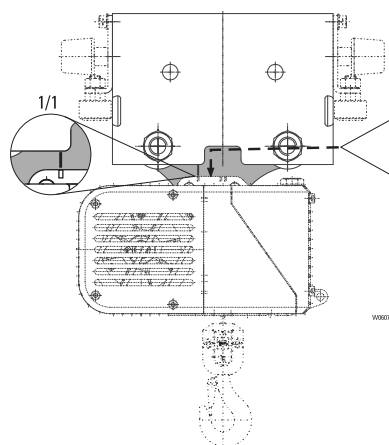

KFN10/32 2/1

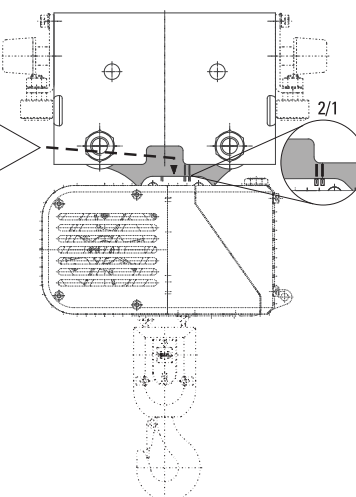

2. Slide trolley onto runway or push on from below after swivelling the side cheeks up.
3. Check that screws and nuts are tightened with specified torque, see page 12.
4. The screw retentions must be fitted!

### 3 Installation

#### 3.3 Installing trolley on chain hoist (continued)

##### 1. KFN 63

Fit suspension piece with suspension bolt (a) to chain hoist. Observe installation position of suspension piece for 1/1 and 2/1 reeving! Lock bolt (a) with washer (b) and circlip (c). See sketch

##### KFN 63 2/1

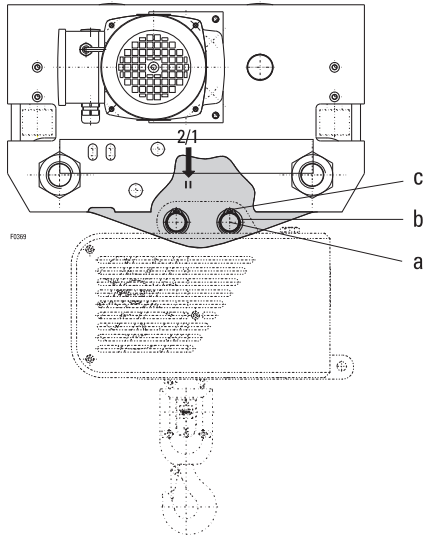

##### KE-T 22

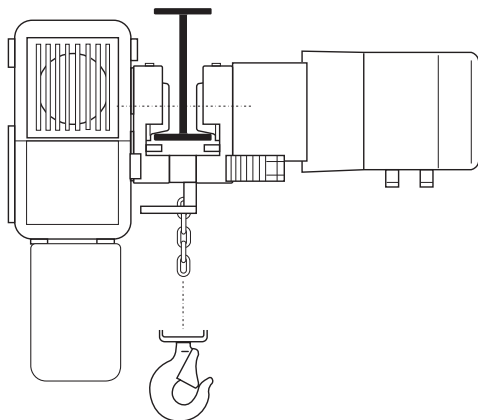

##### KFK ..

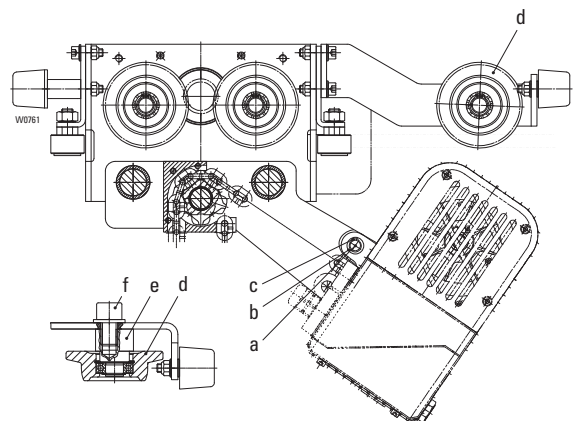

Wheel Ø	Max. S.W.L. [kg]
50	500
63	500 (KE-T)
63	1000
80	3200
125	6300

2. Slide trolley onto runway or push on from below after swivelling the side cheeks up.

3. Check that screws and nuts are tightened with specified torque, see page 12.

4. The screw retentions must be fitted!

##### KFK ..

5. Turn wheel (d) by means of cam (e) until it is in contact with the running surface of the runway.  
Tighten screw (f).

**N.B.:** The guide roller must be flush with the wheels.

### 3 Installation

#### 3.4 Connecting electric trolley

Plug connection cable into chain hoist and secure.

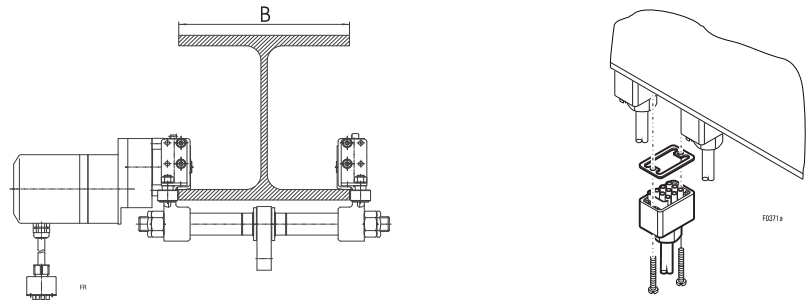

#### 3.5 Fitting guide rollers

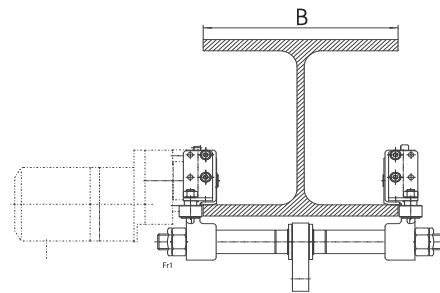

KFN / KFK 10/ 32:  $B \geq 260$   
 KFN / KFK 63 B:  $\geq 300$

#### 3.6 Runway endstop

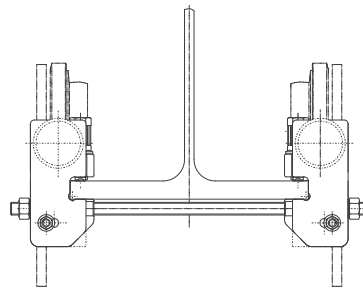

#### 3.7 Fitting and securing chain box

ST 05

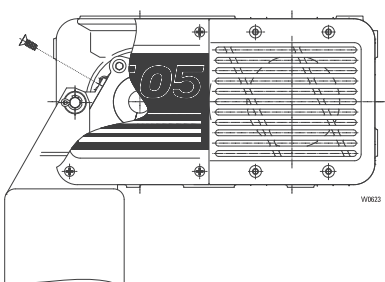

ST 10/ ST20/ ST30

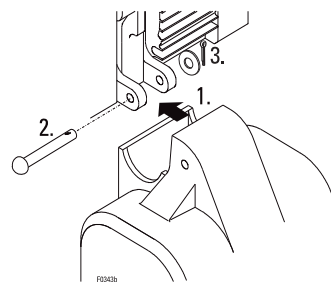

ST10, ST20, ST30

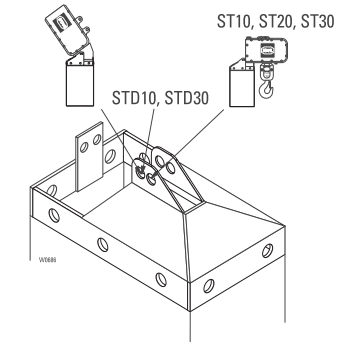

ST 32/ ST50/ST60

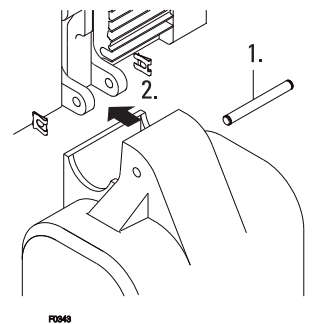

**Lubricate chain with the chain lubricant supplied!**  
**Chain box must be able to move freely.**  
**Max. length of chain see sticker on chain box.**

### 3 Installation

#### 3.8 Fitting control pendant

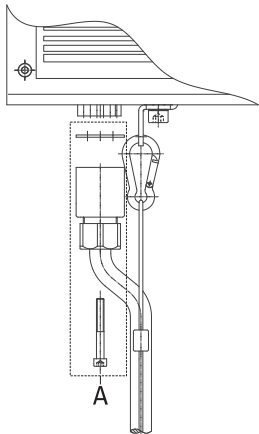

#### N.B.:

The control pendant must be suspended from the strain relief wire and not from the cable!

Ensure sufficient clearance of the cable to the chain by turning the plug if necessary ( $\pm 360^\circ$ )! The cable must **not** touch the chain.

1. Plug in and secure cable.
2. Fit strain relief wire.

If the customer connects the control cable by means of a plug kit, the circuit diagram must be followed (parts marked "A" are supplied loose).

Prepare ends of cable acc. to sketch "Mains connection, plug-type".

For connecting control pendant without plug, see circuit diagram supplied. (Terminal strip X1, terminals 1...9. Connection is via a cable gland.)

#### 3.9 Checking screw connections

M..	[Nm]	M..	[Nm]
M5	6	M16	120
M5*1	5	M20	300
M5*2	1,0	M20x1,5	300
M5*3	1,5	M24	320
M6	10	M30	640
M8	24	M36	1100
M8*1	15		
M10	48		
M12	83		

- Chain guide attachment
- Distance bolt on trolley
- Trolley suspension

\*1 Self-locking/self-tapping screws (ST05)

\*2 Plug connection

\*3 Cable gland (in plastic)

#### 3.10 Mains connection



#### Safety note

The chain hoist may only be connected by a skilled electrician.

The mains cable must meet the specifications given in the technical data, see page 28.

#### Plug-in mains connection

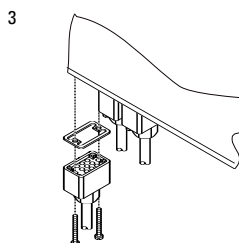
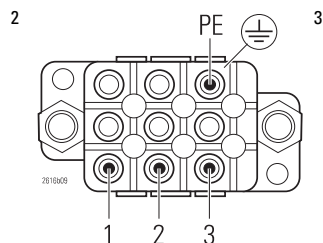
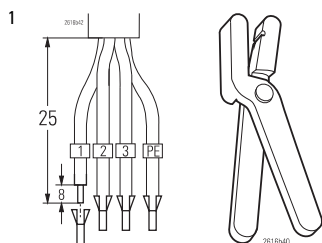

#### Mains connection with cable gland

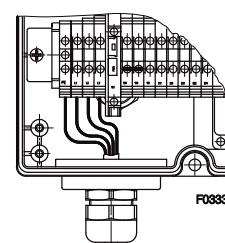

#### 3.11 Dismantling

#### Dismantling chain hoist

1. Remove load from hoist
2. Disconnect chain hoist from mains at main isolator
3. Disconnect electrical connections
4. Remove chain hoist
5. Remove trolley, if any
6. Clean chain hoist and oil lightly
7. Seal air vent screw in gear.

## 4 Commissioning

---



The **test before first commissioning** must be carried out by a **qualified person**, see page 2.

This applies for all chain hoists with electric trolley.  
An exception is made for chain hoists with an S.W.L. <1000 kg with push trolley or in stationary design.\* (Monorail with push trolley, or stationary attachment.)

The following test steps must also be performed when recommissioning after a period in storage or stoppage.

### 4.1 Checklist for commissioning

#### Test steps

- Remove sticker from air vent screw in gear
- Check suspension hook or suspension (visual inspection)
- Check tightening torque of screw connections on hooks
- Check load chain
  - clean and oiled
  - must not be twisted on 2-fall reeving
- Check chain box
  - attachment
- Attach chain stopper to chain with hook at floor level and check chain anchorage
- Measure and record hook aperture
- Check electrical connection
- Check runway
  - clean, free of grease and paint, even
  - end stops present
- Check tightening torque of screw connections of suspension piece or trolley suspension.
- Open step of travel drive clean and greased.



**During the following test steps, you must be able to activate the emergency off button at all times.**

- Check function of chain hoist
  - Direction of movement must correspond to the symbols on the control pendant.  
If not, reverse two phases of the mains connection. (Do not open manufacturer's control.)
- Check function of slipping clutch without load, see page 18, after a long standstill the coupling moment may have altered.
- Check function of brake, see page 20
- Check function of travel drive
  - Direction of motion must correspond to the symbols on the control pendant.
  - Check function of brake, see page 20.
- Check function of overload protection (slipping clutch, see page 18)
- Confirm correct commissioning in test logbook.

If required by national regulations, have chain hoist tested before commissioning by a safety organisation (e.g. TÜV).

\* The above exceptions do not apply if the chain hoist is operated on a crane!

## 5 Operating chain hoist

---

### 5.1 Duties of crane operator



When working with chain hoists, the following must be observed:

- Every day before starting work, check brakes, load suspension devices and limit switches and inspect the installation for any visible defects.
- No-one must stand within the danger area of the moving load.
- Do not move loads above people.
- The crane operator must be able to see the whole of the working area. If this is not the case, an assistant must guide the operator.
- Loads must be attached safely and correctly, do not leave suspended loads unattended. Control and emergency stop devices must be within easy reach.
- Do **not** place your hand between edges which may pinch or cut.
- If the chain should become slack, tauten it at slow speed before lifting.
- The slipping clutch is a safety device.
- It must not be activated during normal operation.
- Approach the final positions for lifting, lowering and travelling in normal operation only if an operational limit switch is fitted.
- As far as possible, avoid inching operation (briefly switching on the motor to achieve small movements.) This could damage switchgear and motors.
- Do not move in the opposite direction until the hoist has come to a stop.
- Observe the safety instructions, see page 4, 5.

## 5 Operating chain hoist

### 5.2 Operating from control pendant

2-step

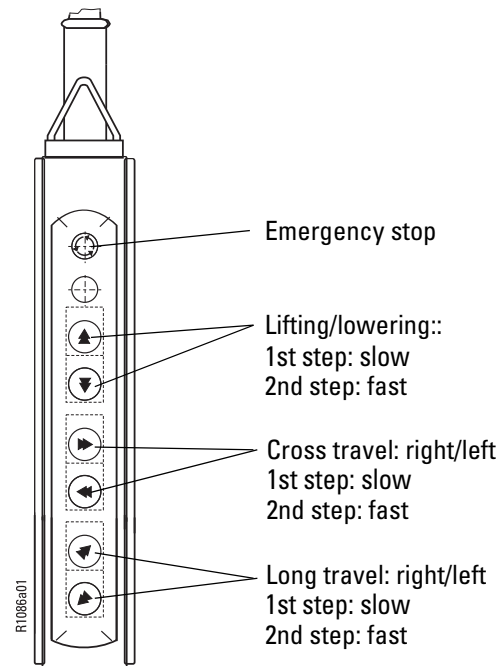

#### Safety note

If the rocker switch is no longer depressed by the operator, it returns to the 0 position, the hoist motion is automatically stopped (dead man's control).  
If the hoist malfunctions, e.g. the actual motion does not correspond to the motion intended in activating the rocker switch, release the rocker switch immediately. If the motion continues, press the emergency stop button.

### 5.3 Emergency stop



Every hoist must have a means of disconnecting the power supply to all drives under load from the ground.

After an emergency stop, the operator must not restart the hoist /crane system until a qualified person has determined that the fault which led to this function being activated has been eliminated and no danger can arise from the continued operation of the system.

- The emergency stop button is on the control pendant.
- Press emergency stop, the system comes to a halt.
- To release the emergency stop: turn the button in the direction shown.

## 6 Maintenance

### 6.1 Maintenance work



Maintenance work on the chain hoist may only be carried out by qualified persons. Maintenance work beyond that described in these operating instructions may only be carried out by the manufacturer or trained after-sales service personnel.

The maintenance intervals below apply to the corresponding mechanism groups in accordance with FEM 9.511. If the chain hoist is operated in the FEM group specified by the manufacturer, the correction factors listed below must be applied for quarterly and annual maintenance work.

1Bm	1Am	2m	4m	Mechanism group (operation)
1	1	2	4	Correction factor

#### Example: Check hook attachment

1 Bm 1 x per quarter

2 m 4 x per quarter

### 6.2 Maintenance intervals

#### 6.2.1 Every day

- Check correct functioning of brake(s).
- Check load chain (visual inspection)
  - clean, lubricated and not twisted
- Check bottom hook block (visual inspection)

#### 6.2.2 Every month

- Check suspension of control pendant (cable and strain relief wire must be fitted).
- Check load chain for wear, see page 17

#### 6.2.3 Every three months

- Check hook for wear, see page 17
- Check hook attachment
- Grease output pinion and open step of gearing on electric trolley
- Check attachment of rigid suspension or trolley suspension
- Clean and lubricate chain
- Check chain attachment (2/1 suspension bolt)

#### 6.2.4 Every year

- Check screw connections (tightening torques, corrosion)
- Adjust brake
- Adjust slipping clutch; function of limit switch is also tested when allowing clutch to slip under overload
- Calculate service life expired. Read operating hours counter if any.
- Check chain stopper (visual inspection)

#### 6.2.5 Every five years

- Gear oil
  - Change oil, see "Oil change" page 21

#### 6.2.6 Safety note

Periodic inspections including maintenance every 12 months, possibly earlier if so prescribed by national regulations, to be performed by a fitter engaged by the manufacturer. Similarly, heavy-duty applications (e.g. multi-shift operation..) or adverse conditions (dirt, solvents) necessitate shortening the inspection and maintenance intervals





## 6 Maintenance

### 6.3 Checking hook for wear

- DIN 15405 part 1

Check load hook or suspension hook for wear. The hook dimensions must not exceed those specified in the following table.

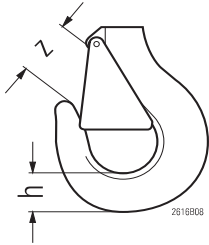

		ST05		ST10		ST20		ST30		ST32		ST50/ST60	
		1/1	2/1	1/1	2/1	1/1	2/1	1/1	2/1	1/1	2/1	1/1	2/1
		[mm]		[mm]		[mm]		[mm]		[mm]		[mm]	
Load hook	h	19	24	19	24	24	31	31	37	31	40	37	48
	h min.	18	22,8	18	22,8	22,8	29,5	29,5	35,2	29,5	38	35,2	45,6
	z	22	29,5	22	29,5	29,5	30	30	33	30	35	33	41
	z max.	24,2	32,5	24,2	32,5	32,5	33	33	36,3	33	38,5	36,5	45,1
Suspension hook	h	24	24	24	24	37	37	37	37	39,5	39,5	39,5	39,5
	h min.	22,8	22,8	22,8	22,8	35,1	35,1	35,1	35,1	37,5	37,5	37,5	37,5
	z	29,5	29,5	31,5	31,5	41	41	41	41	42	42	42	42
	z max.	32,5	32,5	34,6	34,6	45,1	45,1	45,1	45,1	46,2	46,2	46,2	46,2

If load hook or suspension hook should display distortion, breaks, cracks or corrosion impair the lifting capacity they must be replaced.

**N.B.:**

Hook safety latch must close automatically, replace if necessary.

### 6.4 Checking and lubricating load chain

- DIN 685 part 5

- Operate chain hoist under load. If any loud cracking sounds can be heard, check chain, chain sprocket and return sheaves for lubrication and wear.
- Check chain dimensions, measure chain length over 11 links. The chain dimensions must not exceed the values given in the table below.

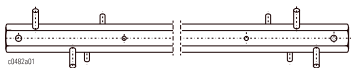
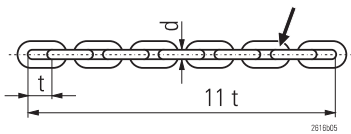

Chain gauge (part no. 14 320 00 65 0)

	ST05	ST10	ST20	ST30	ST32	ST50/ST60
	[mm]	[mm]	[mm]	[mm]	[mm]	[mm]
dxt	4x12	5x16	7x21,9	9x27	9x27	11,3x31
d min	3,6	4,5	6,3	8,1	8,1	10,2
t max	12,5	16,8	23	28,3	28,3	32,5
11 t max	134,4	179,66	245,92	303,18	303,18	350,37

- The load chain must be replaced immediately if it displays distortion, breaks, cracks or corrosion, see page 22

**N.B.:**

Lubricate the load chain above all at the joints.

- Check chain guide, chain sprocket and idler sheave on the bottom hook block and replace if necessary, see page 22
- Check chain anchorage, replace if necessary.

**Caution:** Do not turn and refit a used chain suspension bolt!



### 6.5 Checking function of slipping clutch - without load!

1. Without load, run bottom hook block to top or bottom hook position.
2. Allow slipping clutch to slip in top or bottom hook position for a maximum of 3 sec. The chain must not move, the motor must rotate.

#### N.B.

Slipping clutches and brakes may only be adjusted by a qualified person. When starting to adjust the slipping clutch, the chain drive must be off-loaded! The motor must be at a standstill during all work on the slipping clutch! There is a risk of accidents, we recommend contacting our after-sales service. Before adjustment, the function of the slipping clutch must be checked (see 6.5).

### 6.6 Adjusting slipping clutch - without load

The slipping clutch can be tested easily with the FMD1 slipping clutch testing device, and adjusted if required without any danger to the structural steelwork. 125% of nominal capacity is the specified value for the slipping clutch. The function of the chain hoist must be tested with nominal load at least once a year. Adjusting the slipping clutch with this testing device does not replace this test!

### 6.7 Adjusting slipping clutch with test load

Adjusting the slipping clutch with a test load may only be performed by a qualified person. Before starting, it must be ensured that the entire suspension structure (such as crane, crane runway, crane runway suspensions right up to the roof of the building, etc.) can support the increased load on the chain hoist. Due to the polygon effect, oscillations and tolerances of the friction linings, in accordance with EN 14492-2 adjustment values between min. 110% and max. 160% of nominal load are permissible for chain hoists. If necessary, take the chain hoist down and carry out adjustment on a test stand. The slipping clutch is factory set to 125% nominal load.

**Before adjustment, the function of the slipping clutch must be checked. It is forbidden to hoist test load to top hook position and activate the slipping clutch. The test load may be lifted by a maximum of 300 mm.**

- In bottom hook position attach 1.25 x rated load (test load).
  - Remove cover (1).
  - A small amount of gear oil may escape when the cover is removed (n/a for ST05)
  - Bend back locking plate (2) (ST05).
  - Release slipping clutch setting with clamping screw (2a) (ST32/ST50/ST60)
  - Adjust slipping clutch by turning the adjusting screw or nut (3).
  - Turning to the right → the reaction force increases
  - Turning to the left → the reaction force decreases
- If the reaction force is too high, the adjusting screw or nut must be loosened by one turn.
- Adjust slipping clutch so that the test load is just lifted. The rated load must be held firmly in every position.
  - Bend locking plate (2) up over 2 surfaces of the adjusting screw (ST05).
  - Lock slipping clutch setting with clamping screw (2a) (ST32/ST50/ST60)
- 
- Replace cover (1) and gasket.

ST 05: if no further adjustment is possible, replace clutch  
ST 10 - ST 60: non-wearing lining

## 6 Maintenance

### ST05

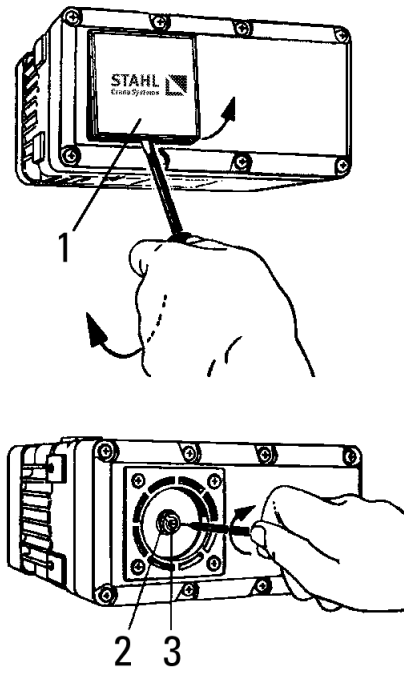

### ST10/ST20/ST30

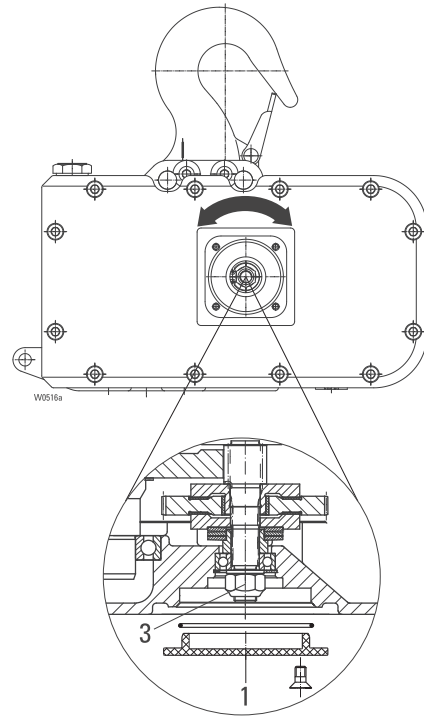

### ST32/ ST50/ST60

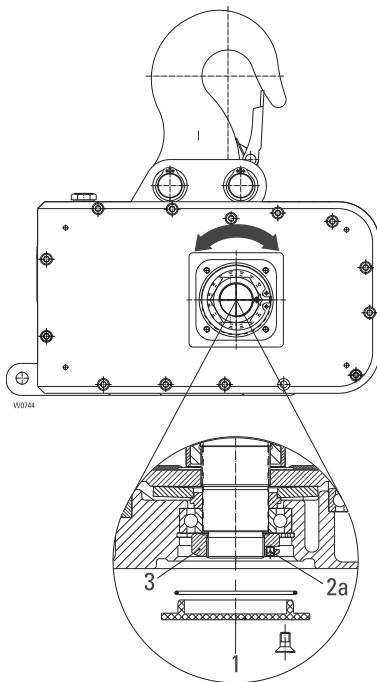

## 6 Maintenance

### 6.8 Hoist motor brake

Check brake at regular intervals

#### 6.8.1 Checking brake

1. Attach rated load
2. Activate brake during lifting and lowering.  
Slowing-down paths of up to 10 cm are permissible.

#### ST05

- Measure distance between fan cover and motor shaft
1. with motor standing still
  2. with motor running

The brake displacement is the difference between these two values. If value (S) is greater than 1.5 mm, the brake must be adjusted. Nominal dimension:  $1 \pm 0.25$  mm.

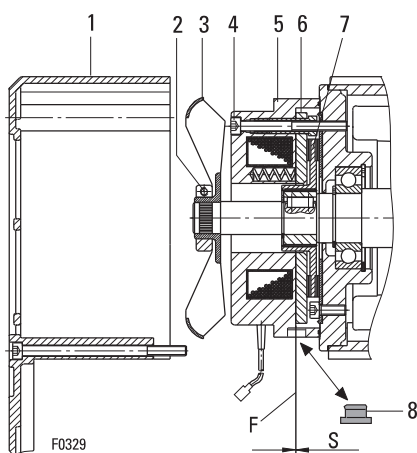
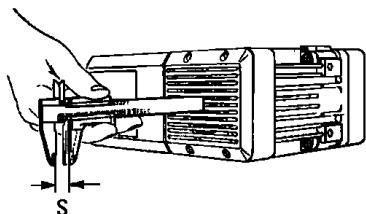

#### ST10 - ST60

1. Remove fan cover (1)
  2. Remove plug (8)
  3. Measure air gap (S) with feeler gauge (F). See table for max. permissible air gap (S). If the max. permissible air gap (S) has been reached, the brake must be replaced
- Clean brake (wear a dust protection mask!)
  - Check friction surfaces for wear

Hoist motor type	S max. [mm]
./E..	1
./E..-MF	0,6

#### 6.8.2 Adjusting brake

#### ST05

- Set load down.  
Calculate number of shims to be removed. The brake displacement is altered by 0.5 mm per shim.  
Example:  
Brake displacement measured: 0.8 mm  
Remove 2 shims: -1.0 mm  
New brake displacement: 0.8 mm
- Lever off cover (1) with a screwdriver.
- Remove 4 screws (2).
- Pull off brake flange (3).
- Remove number of shims (4) calculated.
- Push on brake flange.
- Reassemble in reverse order.
- Check brake displacement.

Replace brake/slipping clutch unit if all shims have been removed. Then reset brake displacement.

**Caution:** After working on brake, always perform a functional test with rated load.

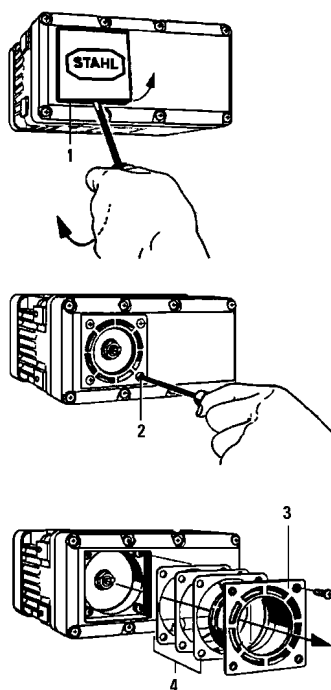

## 6 Maintenance

### 6.9 Travel motor brake

See operating instructions for travel motors

### 6.10 Oil change

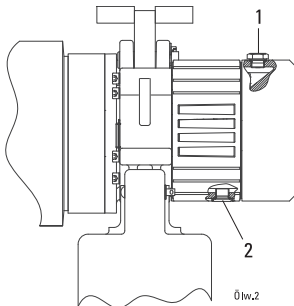

Dispose of used oil in accordance with environmental regulations.

- Change oil while warm if possible.
- See "Technical data" for suitable types and quantity.
- Replace copper gaskets.
- Screw down oil drain plug (2) and oil filling plug (1) (10 Nm).

### 6.11 General overhaul

FEM9.511	1Bm	1Am	2m	3m	4m
D [h]	400	800	1600	3200	6400

The drive mechanism (motor and gear; does not apply to wearing parts) of the ST chain hoist is classified in accordance with FEM 9.511. The theoretical full load lifetime in hours shown opposite (D) is applicable for normal hoist applications. If the full load lifetime (D) minus the lifetime expired is nought, the chain hoist must be overhauled by the manufacturer.

The chain drive is classified in accordance with FEM 9.671.

Components which are in the power flux may only be overhauled by the manufacturer.

### 6.12 Trolley

#### Wheels, wheel drive and runway

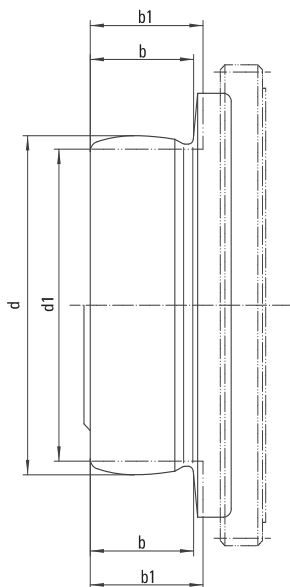

- Visual inspection of wheels for wear. Replace if original diameter is reduced by max. 5%.
- Visual inspection of runway beam for wear. The running characteristics can be improved by a guide system. This avoids wear and the flange play can be reduced.
- Inspection of flanges for wear. A high degree of wear on the flanges indicates that the trolley is canting or running heavily on one side. The cause must be ascertained and eliminated.

d [mm]	d1 [mm]	b [mm]	b1 [mm]
50	≤48	15,5	≥17
63	≤60	17	≥18,5
82	≤76	27,5	≥29,5
100	≤95	33	≥35
125	≤119	38	≥40

Limit for wear → Replace

### 6.13 Operating hours counter

(Option)

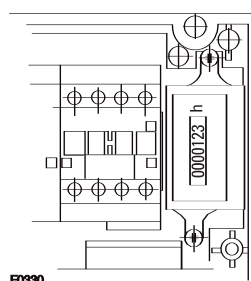

The operating hours counter fitted measures the hoisting time only, thus the value measured must be doubled.

**Example:** 123 h measured; 246 h to be recorded

# 7 Repairs

## 7.1 Chain drive

### 7.1.1 Replacing load chain

Use only original manufacturer chains. Max. chain length, see sticker on chain box.

#### ST05

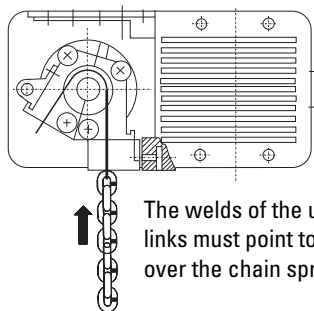

The welds of the upright chain links must point to the outside over the chain sprocket.



#### ST10 - ST60

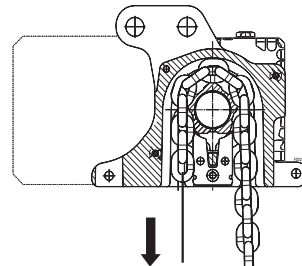
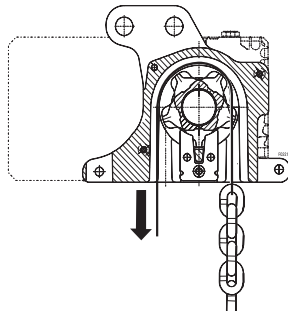

1. Attach a fitting aid, e.g. cable tie, to last link.
  2. Let chain run into guide at slow speed.
- Caution:** risk of injury!

### 7.1.2 Replacing chain stopper

Min. projecting chain length X of free chain end

ST05	X = 130 mm
ST10-ST30	X = 100 mm
ST32-ST60	X = 150 mm

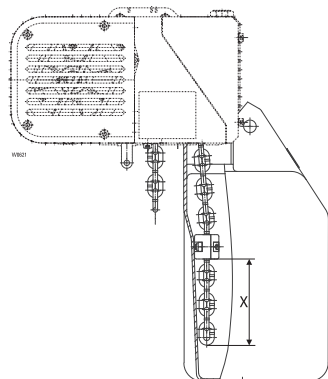

### 7.1.3 Checking and fitting chain anchorage

#### ST05

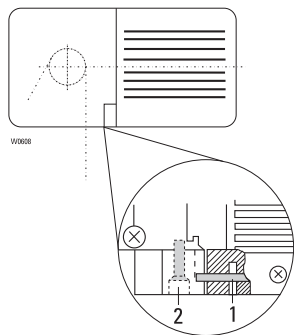

#### ST10 - ST30

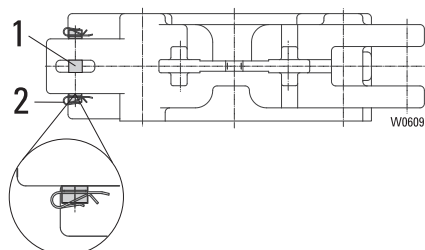

#### ST32/ST50/ST60

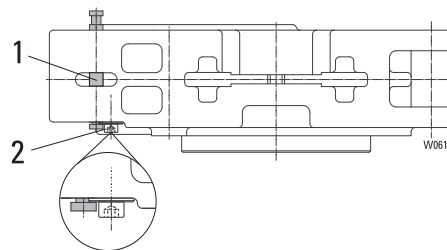

Secure chain suspension bolt (1) with lock (2).  
 Replace chain suspension bolt if any grooves or distortion are visible.  
**Caution:** Do not turn over and refit a used chain suspension bolt!

## 7 Repairs

### 7.1 Chain drive (continued)

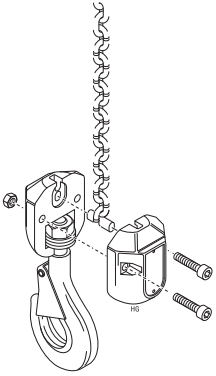

#### 7.1.4 Replacing single-fall bottom hook block

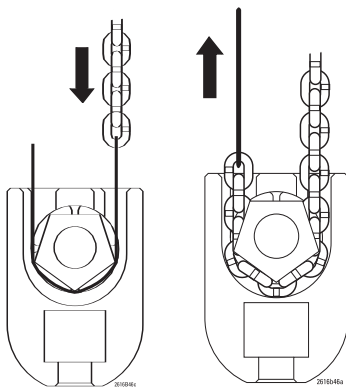

#### 7.1.5 Replacing two-fall bottom hook block

1. Unscrew chain anchorage.
2. Run chain into new bottom hook block.
3. Refit chain anchorage.
4. Grease moving parts.
5. Run through hook path, check that chain is not twisted.

#### 7.1.6 Replacing return sheave

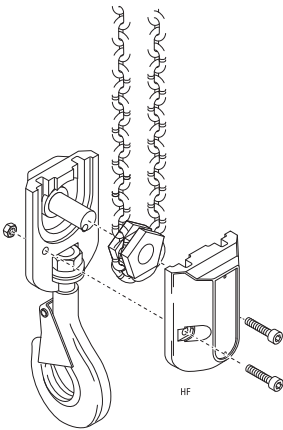

## 8 Wearing parts

### 8.1 Hoist

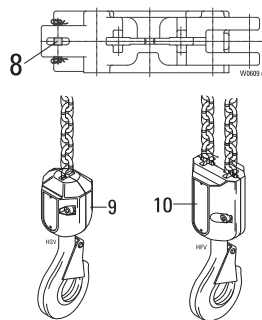
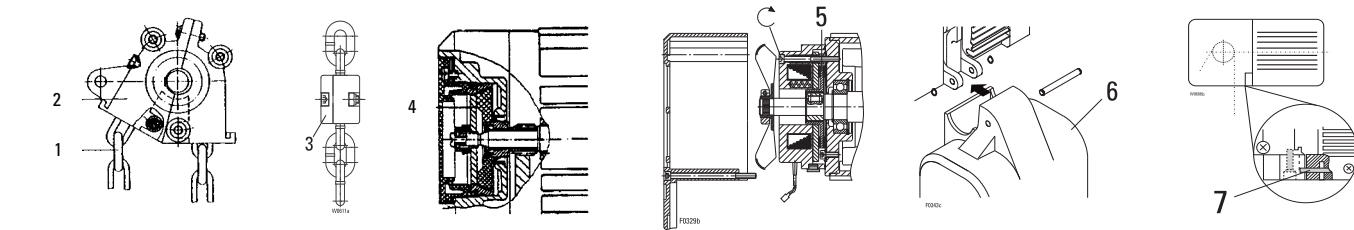

	Designation	ST05	ST10	ST20	ST30	ST32	ST50	ST 60
1*1	Chain	331 005 9	331 006 9	331 001 9	331 004 9	331 004 9	331 013 9	331 023 9
2	Chain drive	nBh	nBh	nBh	nBh	nBh	nBh	nBh
		32 320 96 30 0	14 320 00 41 0	16 320 00 41 0	13 320 00 41 0	17 320 00 41 0	18 320 00 41 0	19 320 00 41 0
		kBh	kBh	kBh	kBh	kBh	kBh	kBh
		32 320 96 30 0	14 320 01 41 0	16 320 01 41 0	13 320 01 41 0	18 320 02 41 0	18 320 01 41 0	19 320 01 41 0
3	Chain stopper	32 320 01 27 0	14 320 01 27 0	16 320 01 27 0	17 320 00 27 0	17 320 00 27 0	18 320 02 27 0	18 320 02 27 0
4	Brake/slipping clutch	32 320 90 30 0	-	-	-	-	-	-
5	Brake/brake set	-	E21	E31	E31	E40/42	E40/42	E40/42
			14 320 09 64 0	16 320 39 64 0	16 320 39 64 0	567 167 0 -100V	567 167 0 -100V	567 167 0 -100V
			E22	E32	E32	567 168 0 -190V	567 168 0 -190V	567 168 0 -190V
			14 320 10 64 0	16 320 40 64 0	16 320 40 64 0	567 169 0 -240V	567 169 0 -240V	567 169 0 -240V
					567 170 0 -290V	567 170 0 -290V	567 170 0 -290V	
6	Chain box	32 320 00 26 0	12m	8m	6m	6m	8m	8m
		32 320 03 20 0	35 322 04 32 0	35 32204 32 0	35 320 04 32 0	17 320 00 32 0	18 320 00 26 0	18 320 00 26 0
		*2	25m	16m	10m	20 m	12m	12m
		33 320 26 26 0	33 320 26 26 0	33 32026 26 0	18 322 00 32 0	18 322 00 32 0	18 322 00 32 0	
7	Suspension bolt	32 322 10 92 0	-	-	-	-	-	-
8	Suspension bolt	-	14 320 00 24 0	16 320 00 24 0	13 320 00 24 0	17 320 00 24 0	18 320 00 24 0	18 320 00 24 0
9	Single-fall bottom hook block	125 kg	14 320 01 59 0	16 320 02 59 0	17 320 00 59 0	17 320 00 59 0	18 320 00 59 0	18 320 00 59 0
		32 320 00 50 0						
		250 kg						
		32 320 01 50 0						
10	Two-fall bottom hook block	32 320 00 50 0	14 320 01 50 0	16 320 03 50 0	13 320 01 50 0	17 320 01 50 0	18 320 01 50 0	19 320 01 50 0

### 8.2 Trolley

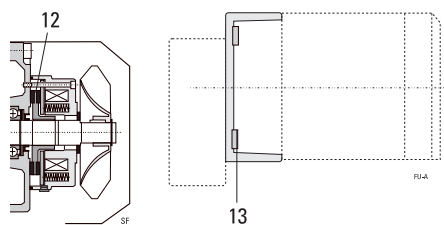

	Designation				
12	Brake disc	SF ... 123 567 100 0	SF ... 133 567 100 0		
13	Brake housing	SU-A 14 .. 1.. 51 250 79 37 0	SU-A 14 .. 2.. 51 250 78 37 0		
15	Wheel	∅ 50	∅ 63 - KE-T	∅ 63 - KF. 10	∅ 80
		a	a	a	a
		01 250 00 41 0	02 250 01 40 0	02 250 03 40 0	03 250 01 64 0
	b	b	b	b	
		01 250 00 41 0	02 250 01 41 0	02 250 02 41 0	03 250 00 64 0
					05 250 04 40 0
					05 250 03 41 0

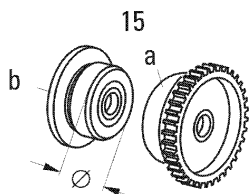

Replacement and repairs may only be performed by skilled personnel!

\*1 Please state length  
\*2 for chain hoist with KE-T trolley  
nBh = standard headroom  
kBh = short headroom



## 9 Technical data

### 9.1 Classification in acc. with FEM (ISO)

1/1					2/1					Type
1Bm (M3)	1Am (M4)	2m (M5)	3m (M6)	4m (M7)	1Bm (M3)	1Am (M4)	2m (M5)	3m (M6)	4m (M7)	
[kg]					[kg]					
-	-	-	125	-	-	-	-	-	-	ST 0501-8
-	-	125	100	-	-	-	-	-	-	ST 0501-16
-	250	200	160	-	-	500	400	320	-	ST 0502-8
320	250	200	160	-	630	500	400	320	-	ST 0503-6
-	400	320	250	-	-	800	630	500	-	ST 1004-16
-	500	400	320	-	-	1000	800	630	-	ST 1005-..
-	-	-	-	630	-	-	-	-	1250	ST 2006-12
-	-	800	630	-	-	-	-	-	-	ST 2008-16
-	-	1000	800	-	-	-	2000	1600	-	ST 2010-8
-	1000	800	630	-	-	2000	1600	1250	-	ST 2010-12
-	-	-	1250	-	-	-	-	-	-	ST 3212-16
1600	1250	1000	800	-	3200	2500	2000	1600	-	ST 3016-8
-	-	1600	1250	-	-	-	3200	2500	-	ST 3216-8
-	1600	1250	1000	-	-	3200	2500	2000	-	ST 3216-12
-	2500	2000	1600	-	-	5000	4000	3200	-	ST 5025-..
3200	2500	2000	1600		6300	5000	4000	3200		ST 6032-6

### 9.2 Ambient conditions

The hoist is designed for use in industry and for the ambient conditions usual in industry.

Special measures must be taken for particular applications such as e.g. high degree of chemical pollution, outdoor use, offshore application, etc.

The manufacturer will be pleased to advise you.

**Protection against dust and moisture in acc. with EN 60 529**  
IP55

#### Permissible ambient temperatures

-20°C ... +40°C (operation)

-20°C ... +60°C (storage)

## 9 Technical data

### 9.3 Hoist

#### 9.3.1 Hoist motor data 50Hz

50 Hz														
Type	Motor type	kW	DC %	c/h	In			Ik			cos φ k	Mains fuse		
					230V	400V	500V	230V	400V	500V		230 V	400 V	500 V
					[A]			[A]						
ST 0501-8	2A04	0,2	40	240	2,3	1,3	1,0	5,7	3,3	2,6	0,88	6	6	6
ST 0501-8/2	2/8A04	0,2/0,05	35/15	120/240	2,3/1,9	1,3/1,1	1,0/0,9	5,7/2,1	3,3/1,2	2,6/1,0	0,88/0,83	6	6	6
ST 0501-16	2A04	0,4	40	240	2,3	1,3	1,0	5,7	3,3	2,6	0,88	6	6	6
ST 0501-16/4	2/8A04	0,4/0,1	35/15	120/240	2,3/1,9	1,3/1,1	1,0/0,9	5,7/2,1	3,3/1,2	2,6/1,0	0,88/0,83	6	6	6
ST 0502-8	2A04	0,4	40	240	2,3	1,3	1,0	5,7	3,3	2,6	0,88	6	6	6
ST 0502-8/2	2/8A04	0,4/0,	35/15	120/240	2,3/1,9	1,3/1,1	1,0/0,9	5,7/2,1	3,3/1,2	2,6/1,0	0,88/0,83	6	6	6
ST 0503-6	2A04	0,4	40	240	2,3	1,3	1,0	5,7	3,3	2,6	0,88	6	6	6
ST 0503-6/1	2/8A04	0,4/0	35/15	120/240	2,3/1,9	1,3/1,1	1,0/0,9	5,7/2,1	3,3/1,2	2,6/1,0	0,88/0,83	6	6	6
ST 1005-8	2E21	0,8	60	360	3,4	2,0	1,6	20,0	11,5	9,2	0,79	10	6	6
ST 1005-8/2	2/8E21	0,8/0,2	40/20	120/240	3,7/2,1	2,2/1,2	1,7/1,0	15,8/4	9,1/2,3	7,3/1,8	0,89/0,73	6	6	6
ST 1005-12	2E22	1,2	60	360	5,4	3,1	2,5	28,2	14,3	13,0	0,85	10	6	6
ST 1005-12/3	2/8E22	1,2/0,3	40/20	120/240	7,1/3,8	4,1/2,2	3,3/1,8	20,5/6,8	11,8/3,9	9,4/3,1	0,93/0,77	10	6	6
ST 2006-12	2E31	1,5	60	360	6,3	3,6	2,9	28,9	16,6	13,3	0,82	16	10	6
ST 2006-12/3	2/8E31	1,5/0,37	40/20	120/240	6,8/3,7	3,9/2,1	3,1/1,7	25,6/7,3	14,7/4,2	11,8/3,4	0,92/0,80	10	6	6
ST 2010-8	2E31	1,5	60	360	6,3	3,6	2,9	28,9	16,6	13,3	0,82	16	10	6
ST 2010-8/2	2/8E31	1,5/0,37	40/20	120/240	6,8/3,7	3,9/2,1	3,1/1,7	25,6/7,3	14,7/4,2	11,8/3,4	0,92/0,80	10	6	6
ST 2010-12	2E32	2,3	60	300	9,0	5,7	4,6	55,7	24,5	19,6	0,90	20	10	10
ST 2010-12/3	2/8E32	2,3/0,57	40/20	120/240	9,9/5,2	5,7/3,0	4,6/2,4	42,6/10,6	24,5/6,1	19,6/4,9	0,90/0,79	16	10	10
ST 3016-8	2E32	2,3	60	300	9,0	5,7	4,6	55,7	24,5	19,6	0,90	20	10	10
ST 3016-8	2/8E32	2,3/0,57	40/20	120/240	9,9/5,2	5,7/3,0	4,6/2,4	42,6/10,6	24,5/6,1	19,6/4,9	0,90/0,79	16	10	10
ST 3212-16	2E42	3,8	60	360	15,7	9,0	7,2	66,8	38,4	30,7	0,8	20	16	16
ST 3212-16/4	2/8E42	3,8/0,9	33/17	100/200	16,0/7,0	9,2/4,0	7,4/3,2	55,7/14,3	32,0/8,2	25,6/6,6	0,86/0,82	20	16	10
ST 3216-8	2E40	2,4	60	360	9,7	5,7	4,5	55,7	25,0	25,6	0,87	20	16	10
ST 3216-8/2	2/8E40	2,4/0,6	40/20	120/240	10,3/5,4	5,7/3,0	4,6/2,4	43,5/10,8	25,0/6,2	20,0/5,0	0,87/0,74	16	10	10
ST 3216-12	2E42	3,8	60	360	15,7	9,0	7,2	66,8	38,4	30,7	0,80	20	16	16
ST 3216-12/3	2/8E42	3,8/0,9	33/17	100/200	16,0/7,0	9,2/4,0	7,4/3,2	55,7/14,3	32,0/8,2	25,6/6,6	0,86/0,82	20	16	10
ST 5025-6	2E42	3,0	70	420	11,1	7,3	5,1	66,8	38,4	30,7	0,80	20	16	16
ST 5025-6/1	2/8E42	3,0/0,76	40/20	120/240	12,7/6,9	7,3/3,8	5,8/3,2	55,7/14,3	32,0/8,2	25,6/6,6	0,86/0,82	20	16	10
ST 5025-8	2E42	3,8	60	360	15,7	9,0	7,2	66,8	38,4	30,7	0,80	20	16	16
ST 5025-8/2	2/8E42	3,8/0,9	33/17	100/200	16,0/7,0	9,2/4,0	7,4/3,2	55,7/14,3	32,0/8,2	25,6/6,6	0,86/0,82	20	16	10
ST6032-6/1	2/8E42	3,8/0,9	33/17	100/200	16,0/7,0	9,2/4,0	7,4/3,2	55,7/14,	32,0/8,2	25,6/6,6	0,86/0,82	20	16	10

## 9 Technical data

### 9.3.2 Hoist motor data 60 Hz

60 Hz														
Type	Motor type	kW	DC %	c/h	In			Ik			cos φ k	Mains fuse		
					400V	460V	575V	400V	460V	575V		400 V	460 V	575 V
					[A]			[A]						
ST 0501-8	2A04	0,24	40	240	1,6	1,4	1,1	4,0	3,5	2,8	0,88	6	6	6
ST 0501-8/2	2/8A04	0,24/0,06	35/15	180/360	1,6/1,3	1,4/1,1	1,1/0,9	4,0/1,5	3,5/1,3	2,8/1,0	0,88/0,83	6	6	6
ST 0501-16	2A04	0,48	40	240	1,6	1,4	1,1	4,0	3,5	2,8	0,88	6	6	6
ST 0501-16/4	2/8A04	0,48/0,12	35/15	120/240	1,6/1,3	1,4/1,1	1,1/0,9	4,0/1,5	3,5/1,3	2,8/1,0	0,88/0,83	6	6	6
ST 0502-8	2A04	0,48	40	240	1,6	1,4	1,1	4,0	3,5	2,8	0,88	6	6	6
ST 0502-8/2	2/8A04	0,48/0,12	35/15	120/240	1,6/1,3	1,4/1,1	1,1/0,9	4,0/1,5	3,5/1,3	2,8/1,0	0,88/0,83	6	6	6
ST 0503-6	2A04	0,48	40	240	1,6	1,4	1,1	4,0	3,5	2,8	0,88	6	6	6
ST 0503-6/1	2/8A04	0,48/0,12	35/15	120/240	1,6/1,3	1,4/1,1	1,1/0,9	4,0/1,5	3,5/1,3	2,8/1,0	0,88/0,83	6	6	6
ST 1005-8	2E21	0,96	60	360	2,2	2,0	1,6	13,2	11,5	9,2	0,79	6	6	6
ST 1005-8/2	2/8E21	0,96/0,24	40/20	120/240	2,5/1,4	2,2/1,2	1,7/1,0	10,5/2,6	9,3/2,3	7,3/1,8	0,89/0,73	6	6	6
ST 1005-12	2E22	1,4	60	360	3,6	3,1	2,5	18,6	16,2	13,0	0,85	10	6	6
ST 1005-12/3	2/8E22	1,4/0,36	40/20	120/240	4,7/2,5	4,1/2,2	3,3/1,8	13,6/4,5	11,8/3,9	9,4/3,1	0,93/0,77	6	6	6
ST 2006-12	2E31	1,8	60	360	4,1	3,6	2,9	19,1	16,6	13,3	0,82	10	10	6
ST 2006-12/3	2/8E31	1,8/0,44	40/20	120/240	4,5/2,4	3,9/2,1	3,1/1,7	16,9/4,8	14,7/4,2	11,8/3,4	0,92/0,80	10	6	6
ST 2010-8	2E31	1,8	60	360	4,1	3,6	2,9	19,1	16,6	13,3	0,82	10	10	6
ST 2010-8/2	2/8E31	1,8/0,44	40/20	120/240	4,5/2,4	3,9/2,1	3,1/1,7	16,9/4,8	14,7/4,2	11,8/3,4	0,92/0,80	10	6	6
ST 2010-12	2E32	2,8	60	360	6,6	5,7	4,1	28,2	24,5	25,6	0,90	10	10	10
ST 2010-12/3	2/8E32	2,8/0,68	40/20	120/240	6,6/3,5	5,7/3,0	4,6/2,4	28,2/7,0	24,5/6,1	19,6/4,9	0,90/0,79	10	10	10
ST 3016-8	2E32	2,8	60	360	6,6	5,7	4,1	28,2	24,5	25,6	0,90	10	10	10
ST 3016-8	2/8E32	2,8/0,68	40/20	120/240	6,6/3,5	5,7/3,0	4,6/2,4	28,2/7,0	24,5/6,1	19,6/4,9	0,90/0,79	10	10	10
ST 3212-16	2E42	4,6	60	360	10,4	9,0	7,2	44,2	38,4	30,7	0,80	16	16	16
ST 3212-16/4	2/8E42	4,6/1,1	33/17	100/200	10,6/4,6	9,2/4,0	7,4/3,2	36,8/9,4	32,0/8,2	25,6/6,6	0,86/0,82	16	16	16
ST 3216-8	2E40	2,9	60	360	6,4	5,6	4,5	36,8	32,0	25,6	0,87	16	16	10
ST 3216-8/2	2/8E40	2,9/0,72	40/20	120/240	6,6/3,5	5,5/3,0	4,6/2,4	28,8/7,1	25,0/6,2	20,0/5,0	0,87/0,74	16	10	10
ST 3216-12	2E42	4,6	60	360	10,4	9,0	7,2	44,2	38,4	30,7	0,80	16	16	16
ST 3216-12/3	2/8E42	4,6/1,1	33/17	100/200	10,6/4,6	9,2/4,0	7,4/3,2	36,8/9,4	32,0/8,2	25,6/6,6	0,86/0,82	16	16	16
ST 5025-6	2E42	3,6	70	420	7,4	6,4	5,1	44,2	38,4	30,7	0,78	16	16	16
ST 5025-6/1	2/8E42	3,6/0,91	40/20	120/240	8,4/4,4	7,3/3,8	5,8/3,0	36,8/9,4	32,0/8,2	25,6/6,6	0,78/0,49	16	16	16
ST 5025-8	2E42	4,6	60	360	10,4	9,0	7,2	44,2	38,4	30,7	0,80	16	16	16
ST 5025-8/2	2/8E42	4,6/1,1	33/17	100/200	10,6/4,6	9,2/4,0	7,4/3,2	36,8/9,4	32,0/8,2	25,6/6,6	0,86/0,82	16	16	16
ST 6032-6/1	2/8E42	4,6/1,1	33/17	100/200	10,6/4,6	9,2/4,0	7,4/3,2	36,8/9,4	32,0/8,2	25,6/6,6	0,86/0,82	16	16	16

## 9.4 Trolley

### 9.4.1 Pole-changing travel motors 50Hz

50 Hz														
Type	Motor Typ	kW	ED %	c/h	In			Ik			cos φ k	Mains fuse		
					230V	400V	500V	230V	400V	500V		230 V	400 V	500 V
					[A]			[A]						
SU-A	2/8A04	0,07/0,32	20/40	-	1,9/2,1	1,1/1,2	0,9/1,0	2,1/5,6	1,2/3,2	1,0/2,6	0,84/0,89	-	-	-
SF 14	8/2F12	0,09/0,37	20/40	-	1,7/2,3	1,0/1,3	0,8/1,0	2,4/5,6	1,4/3,2	1,1/2,6	0,74/0,9	-	-	-

### 9.4.2 Pole-changing travel motors 60Hz

60 Hz														
Type	Motor Typ	kW	ED %	c/h	In			Ik			cos φ k	Mains fuse		
					400	460V	575V	400V	460V	575V		400 V	460 V	575 V
					[A]			[A]						
SU-A	2/8A04	0,09/0,38	20/40	-	1,3/1,4	1,2/1,3	0,9/1,0	1,4/3,7	1,3/3,5	1,0/2,6	0,84/0,89			
SF 14	8/2F12	0,11/0,44	20/40	-	1,2/1,5	1,0/1,3	0,8/1,0	1,6/3,7	1,4/3,2	1,1/2,6	0,76/0,89	-	-	-

## 9 Technical data

### 9.5 Specifications for mains connection

#### Specifications for mains connection

- All poles of the mains cable must be disconnected by a lockable switch.
- The mains voltage must correspond to that stated on the rating plate.
- Fixed installed cables e.g. NYM, NYY
- Flexible cables e.g. RN-F, NGFLGöu, H07VVH2-F
- Cable cross-section min. 1.5 mm<sup>2</sup>
- Mains voltage 380-415 VAC, 50 Hz  
Other mains voltages are available as options.
- In accordance with **EN 50014** a radio interference suppression module FEM1 must be installed for all motors ≤1 kW
- If a current-operated circuit-breaker is used, a fault current of approx. 17 mA must be taken into account for each FEM1.

#### 9.5.1 Max. length of supply cable

Direct control													
50 Hz		Max. cable length with direct control [m]											
Chain hoist		Stationary *1						With trolley along runway *2					
Connecting cable cross-section		1.5 mm <sup>2</sup>			2.5 mm <sup>2</sup>			1.5 mm <sup>2</sup>			2.5 mm <sup>2</sup>		
		230 V	400 V	500 V	230 V	400 V	500 V	230 V	400 V	500 V	230 V	400 V	500 V
Hoist motor type *	2A04	57	170	269	94	283	-	29	80	120	49	-	-
	2/8A04												
	2E21	17	50	79	28	84	131	10	30	47	17	50	79
	8/2E21	18	55	87	31	92	144	11	33	52	18	55	87
	2E22	13	38	60	21	64	99	8	23	36	13	38	60
	8/2E22	14	42	65	23	70	109	8	25	39	14	42	65
	2E31	11	34	53	19	57	89	7	21	32	11	34	53
	8/2E31	11	34	53	19	57	89	7	21	32	11	34	53

Contactor control													
50 Hz		Max. cable length with contactor control [m]											
Chain hoist		Stationary *3						With trolley along runway *4					
Connecting cable cross-section		1,5 mm <sup>2</sup>			2,5 mm <sup>2</sup>			1,5 mm <sup>2</sup>			2,5 mm <sup>2</sup>		
		230 V	400 V	500 V	230 V	400 V	500 V	230 V	400 V	500 V	230 V	400 V	500 V
Hoist motor type *	2A04	113	340	531	-	-	-	71	214	334	118	-	-
	8/2A04												
	2E21	36	109	170	60	181	283	27	81	126	44	134	210
	8/2E21	40	122	190	67	203	317	29	89	139	49	148	231
	2E22	27	81	112	45	135	121	20	61	96	34	102	159
	8/2E22	30	90	141	50	150	234	22	67	104	37	111	174
	2E31	24	73	113	40	121	189	18	55	86	30	91	143
	8/2E31	24	73	114	40	122	190	18	55	86	30	91	142
	2E32	-	45	60	21	75	99	-	34	46	16	57	77
	8/2E32	15	45	70	25	75	117	11	34	54	19	57	90
	2E40	-	45	62	22	66	103	-	31	48	17	58	80
	8/2E40	15	45	71	25	76	118	12	35	55	19	58	91
	2E42	-	32	50	18	54	93	-	25	43	14	42	72
	8/2E42	-	36	56	20	60	93	-	28	43	15	46	72

\* Allocation to chain hoists see "Motor data" table

\*1 Voltage drop 2.5%

\*2 Voltage drop 1.5%

\*3 Voltage drop 5.0%

\*4 Voltage drop 4.0%

## 9 Technical data

### 9.5.2 M1ax. length of supply cable

Direct control													
60 Hz		Max. cable length with direct control [m]											
Chain hoist		Stationary *1						With trolley along runway *2					
Connecting cable cross-section		1.5 mm <sup>2</sup>			2.5 mm <sup>2</sup>			1.5 mm <sup>2</sup>			2.5 mm <sup>2</sup>		
		230 V	400 V	460 V	230 V	400 V	460 V	230 V	400 V	460 V	230 V	400 V	460 V
Hoist motor type *	2A04 8/2A04												
	2E21	14	44	58	24	73	97	9	26	35	14	44	58
	8/2E21	16	48	64	27	80	106	10	29	38	16	48	64
	2E22	12	30	39	20	49	65	7	18	23	12	30	39
	8/2E22	12	36	48	20	61	80	7	22	29	12	36	48
	2E31	10	30	40	16	50	66	6	18	24	10	30	40
8/2E31	10	30	40	16	50	66	6	18	24	10	30	40	

Contactor control													
60 Hz		Max. cable length with contactor control [m]											
Chain hoist		Stationary *3						With trolley along runway *4					
Connecting cable cross-section		1.5 mm <sup>2</sup>			2.5 mm <sup>2</sup>			1.5 mm <sup>2</sup>			2.5 mm <sup>2</sup>		
		400 V	460 V	575 V	400 V	460 V	575 V	400 V	460 V	575 V	400 V	460 V	575 V
Hoist motor type *	2A04 8/2A04	113	340	531	-	-	-	71	214	334	118	-	-
	2E21	36	109	170	60	181	283	27	81	126	44	134	210
	8/2E21	40	122	190	67	203	317	29	89	139	49	148	231
	2E22	27	81	112	45	135	121	20	61	96	34	102	159
	8/2E22	30	90	141	50	150	234	22	67	104	37	111	174
	2E31	24	73	113	40	121	189	18	55	86	30	91	143
	8/2E31	24	73	114	40	122	190	18	55	86	30	91	142
	2E32	-	45	60	21	75	99	-	34	46	16	57	77
	8/2E32	15	45	70	25	75	117	11	34	54	19	57	90
	2E40	-	45	62	22	66	103	-	31	48	17	58	80
8/2E40	15	45	71	25	76	118	12	35	55	19	58	91	
2E42	-	32	50	18	54	93	-	25	43	14	42	72	
8/2E42	-	36	56	20	60	93	-	28	43	15	46	72	

\* Allocation to chain hoists see "Motor data" table

\*1 Voltage drop 2.5%

\*2 Voltage drop 1.5%

\*3 Voltage drop 5.0%

\*4 Voltage drop 4.0%

## 9 Technical data

### 9.6 Lubricants

ST05

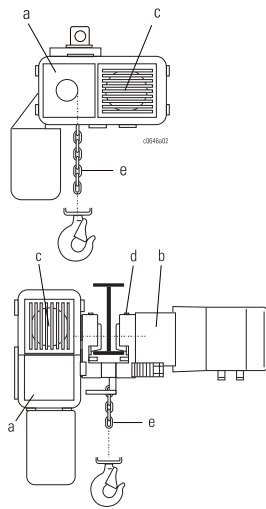

ST10  
ST20  
ST30  
ST32  
ST50  
ST60

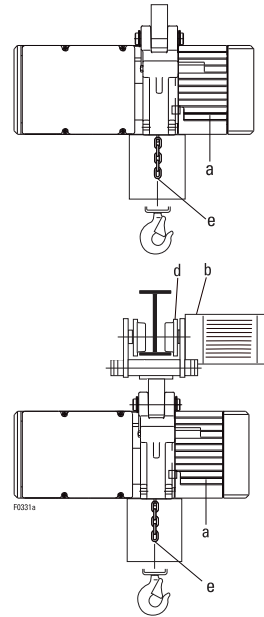

Lubrication point	Type of lubricant	Designation DIN 51502	Quantity	Characteristics, makes	
a = Hoist gear	Oil	CLP 460 (PG 220)	ST 10: 700 ml ST 10: 1000 ml*1 ST 20: 1200 ml ST 20: 1500 ml*1 ST 30: 1200 ml ST 30: 1500 ml*1 ST 32: 2000 ml ST 32: 2500 ml*1 ST 50/ST60: 2000 ml ST 50/ST60: 2500 ml*1	1 2	1 Viscosity 460 cSt/40°C, pour point -20°C, flash point +265°C e.g. Fuchs Renep Compound 110*, Aral Degol BG 460, BP Energol GR-XP 460, Esso Spartan EP 460, Mobilgear 634, Shell Omala Oil 460, Texaco Meropa 460 2 Viscosity 460 cSt/40°C, pour point -40°C, flash point +320°C e.g. Shell Tivela Oil WB 3 Soap base: natron, dripping point approx. +150°C, penetration: 400-430, operating temperature: -30°C to 80°C e.g. Aralub PDP 00, BP Energrease HT 00 EP, ESSO Liquid Gear Grease
	Grease	G00F (GPG00K)	ST 05: 250 ml	3 4	4 Soap base: Li / polyglycol oil, dripping point approx. + 180°C, penetration 400 - 430, operating temperature: down to -40°C e.g. Esso liquid grease S 420
b = Trolley gear	Grease	G00F (GPG00K)	SU-A: 180 g SF 14-1... 100 g SU-A: 180 g SF 14-1... 100 g	3 4	5 Oil or liquid grease Normal ambient conditions: Ceplattyn Chain Lubricant Fluid Extreme applications, food industry, medicinal baths: SKD 3000
c = Hoist motor bearing, shaft seal	Grease	G00F (GPG00K)	ST 05: approx. 50 g	3 4	
d = Wheel gearing	Grease	G00F (GPG00K)		3 4	
e = Chain	Oil	-		5	

( (Lubricant for low ambient temperatures, max. -40°C)

\*1 Short headroom, dual chain hoist

## 9 Technical data

### 9.7 Sound pressure level

#### Hoist

Sound level at 1 m from chain hoist, averaged out for an operating cycle of 50% with rated load and 50% without load.

Typ	[dB A]
ST05 - ST 60	74

#### Travel drives

The sound pressure level was measured at a distance of 1 m from the crane. The mean noise level calculated for one operating cycle (50% with nominal load, 50% without load) can be seen from the tables.

Instead of stating an emission value based on a workplace, the values from the tables at measuring distance "h" can be used.

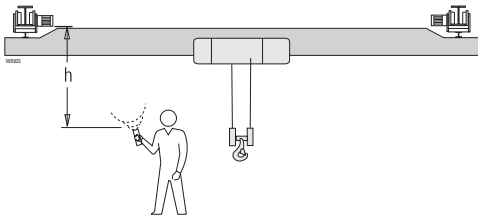





#### Indoors

Travel drive type	[db (A)] +/- 3				
	h [m]				
	1 m	2 m	4 m	8 m	16 m
SU-A ..	78	75	72	69	66
SF .. 2.. ...	72	69	66	66	63
SF .. 8.. ...	78	75	72	69	66

#### Outdoors

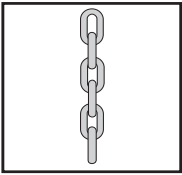
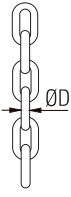
Travel drive type	[db (A)] +/- 3				
	h [m]				
	1 m	2 m	4 m	8 m	16 m
SU-A ..	78	72	66	60	54
SF .. 2.. ...	72	66	60	54	48
SF .. 8.. ...	78	72	66	60	54

### 9.8 Chain certificate

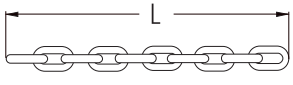
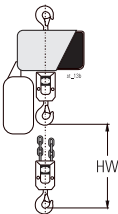
		Order No.					
						1/1	2/1
	[mm]		[kg]	[kN]	[kN]	3 [m]	
	ST 05	331 005 9	320	12,5	20	HW + 0,3	2xHW + 0,4
	ST 10	331 006 9	500	20	32	HW + 0,5	2xHW + 0,6
	ST 20	331 001 9	1000	40	60	HW + 0,6	2xHW + 0,7
	ST 30	331 004 9	1600	63	100	HW + 0,6	2xHW + 0,8
	ST 32	331 004 9	1600	63	100	HW + 0,7	2xHW + 1,0
	ST 50	331 013 9	2500	100	160	HW + 0,7	2xHW + 1,0
	ST 60	331 023 9	3200	100	160	HW + 0,7	2xHW + 1,0

\*1 Tractive force on chain

\*2 Test load

\*3 Minimum breaking load

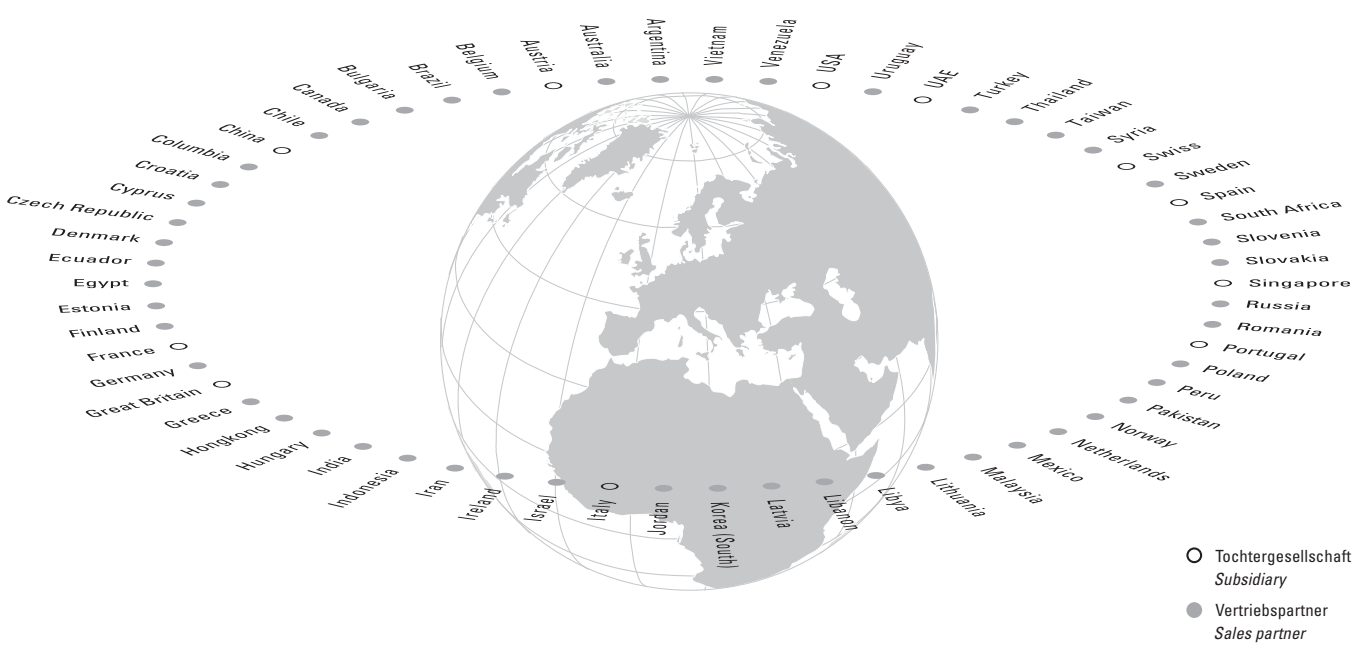

○ **Tochtergesellschaft/Subsidiary**

**Austria**  
Steyregg  
Tel +43 732 641111-0  
Fax +43 732 641111-33  
office@stahlcranes.at

**Great Britain**  
Birmingham  
Tel +44 121 7676400  
Fax +44 121 7676485  
info@stahlcranes.co.uk

**Portugal**  
Lissabon  
Tel +351 21 44471-60  
Fax +351 21 44471-69  
ferrometal@ferrometal.pt

**Switzerland**  
Däniken  
Tel +41 62 82513-80  
Fax +41 62 82513-81  
info@stahlcranes.ch

**China**  
Shanghai  
Tel +86 21 6257 2211  
Fax +86 21 6254 1907  
service\_cn@stahlcranes.cn

**India**  
Chennai  
Tel +91 44 4352-3955  
Fax +91 44 4352-3957  
indiasales@stahlcranes.in

**Singapore**  
Singapore  
Tel +65 6271 2220  
Fax +65 6377 1555  
sales@stahlcranes.sg

**United Arab Emirates**  
Dubai  
Tel +971 4 805-3700  
Fax +971 4 805-3701  
info@stahlcranes.ae

**France**  
Paris  
Tel +33 1 39985060  
Fax +33 1 34111818  
info@stahlcranes.fr

**Italy**  
S. Colombano  
Tel +39 0185 358391  
Fax +39 0185 358219  
info@stahlcranes.it

**Spain**  
Madrid  
Tel +34 91 484-0865  
Fax +34 91 490-5143  
info@stahlcranes.es

**USA**  
Charleston, SC  
Tel +1 843 767-1951  
Fax +1 843 767-4366  
sales@stahlcranes.us

● **Vertriebspartner/Sales partner**

Die Adressen von über 100 Vertriebspartnern weltweit finden Sie im Internet auf [www.stahlcranes.com](http://www.stahlcranes.com) unter Kontakt.  
You will find the addresses of over 100 sales partners on the Internet at [www.stahlcranes.com](http://www.stahlcranes.com) under Contact.

➔ **[www.stahlcranes.com](http://www.stahlcranes.com)**

STAHL CraneSystems GmbH, Daimlerstr. 6, 74653 Künzelsau, Germany  
Tel +49 7940 128-0, Fax +49 7940 55665, marketing@stahlcranes.com

