



---

**Chain Hoists - Options\_**  
Operating and Maintenance Instructions

---

↘ EN



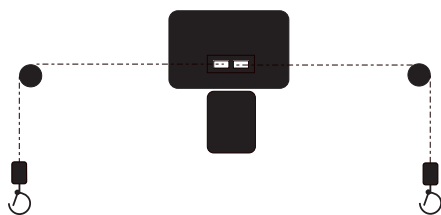

**Chain hoists with two load chains (STD ...)**

<b>1 Safety instructions</b>	Symbols ..... see Op. instr. for ST chain hoists Warranty..... see Op. instr. for ST chain hoists Use for intended purpose ..... see Op. instr. for ST chain hoists Safety-conscious operation..... see Op. instr. for ST chain hoists Organisational safety precautions ..... see Op. instr. for ST chain hoists Electrical voltage ..... see Op. instr. for ST chain hoists Duties of crane operator..... see Op. instr. for ST chain hoists
<b>2 Getting to know the chain hoist</b>	..... see Op. instr. for ST chain hoists
<b>3 Installing</b>	3.1 Installing stationary chain hoist ..... 4 3.2 Installing trolley..... 6 Checking screw connections ..... see Op. instr. for ST chain hoists Mains connection ..... see Op. instr. for ST chain hoists Dismantling ..... see Op. instr. for ST chain hoists
<b>4 Commissioning</b>	4.1 Checklist for commissioning ..... see Op. instr. for ST chain hoists
<b>5 Operating</b>	5.1 Duties of crane operator ..... see Op. instr. for ST chain hoists 5.2 Operating control pendant..... see Op. instr. for ST chain hoists 5.3 Emergency stop ..... see Op. instr. for ST chain hoists
<b>6 Maintenance</b>	..... see Op. instr. for ST chain hoists 6.1 Checking load chains ..... 7 6.2 Replacing load chains..... 7
<b>7 Repairs</b>	..... see Op. instr. for ST chain hoists
<b>8 Wearing parts</b>	..... 9
<b>9 Technical data</b>	..... see Op. instr. for ST chain hoists
<b>10 Declaration of conformity</b>	..... see Op. instr. for ST chain hoists
<b>11 Off-standard equipment</b>	11.1 Lever-type hoist limit switch ..... 10 11.2 Gear limit switch ..... 12

## 3 Installation

### 3.1 Installing chain hoists STD05

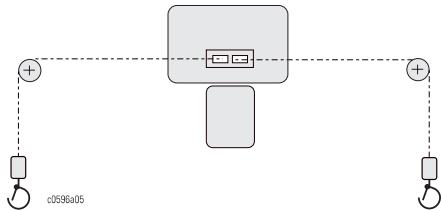

#### 3.1.1 Stationary chain hoist

Install chain hoist and return sheave supports  
Clearances as per Product Information "ST chain hoists"

##### Z version

- Fit chain box.
- Place the ends of the chains (with chain stoppers on the gear side) into the corresponding chambers of the chain box.
- Pull one chain through the opening between the two chambers of the chain box and lead it over the sheave in the return sheave support. (Do not twist chain!)
- Lead the second chain over the sheave into the second return sheave support.
- Shorten the ends of both chains (load side) to the same length. (The chains must not sag while doing so!)

**Before commissioning, run chains out completely to ensure that they are not twisted.**

- Fit bottom hook blocks. (In the case of single-fall blocks, insert a rubber buffer!) In the case of two-fall blocks, attach the ends of the chains to the return sheave supports. (Do not twist chains!)
- 

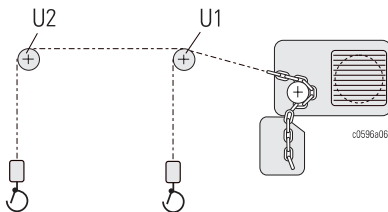

##### E version

- Fit chain box.
- Lead both chains through the return sheave support U1.
- Lead the longer chain end through the return sheave support U2. (Do not twist chain!)
- Cut both chains (load side) to the same length. (Chains must not sag while doing so!)

**Before commissioning, run chains out completely to ensure that they are not twisted.**

- Fit bottom hook blocks (In the case of single-fall blocks, insert a rubber buffer!) In the case of two-fall blocks, attach the ends of the chains to the return sheave supports.

## 3 Installation

STD10.../STD30.../STD50.../STD60...

### 3.1.1 Stationary chain hoist

Install chain hoist and return sheave supports  
Clearances as per Product Information "ST chain hoists"

#### E and Z versions

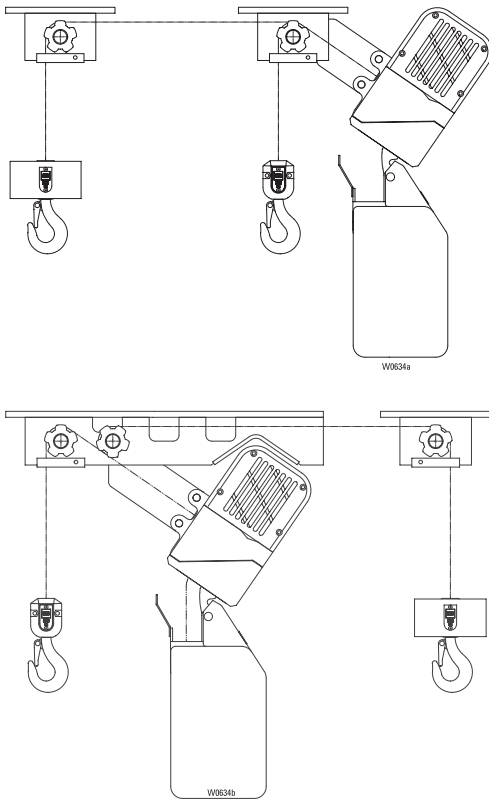

- Run longer chain into chain guide on loose chain and gear side at slow speed.  
**Caution: danger of injury!**
- Run chain over sheaves in both return sheave supports.  
**(Do not twist chain!)**
- Run vertical chain link of second chain into free opening of chain guide on loose fall side at slow speed.  
**Danger of injury!**
- Lead chain over chain sheave in first chain sheave support.  
**(Do not twist chain!)**
- With the chain taut, shorten the chain end of the load side of the first chain to the same distance from the lower edge of the chain sheave support as the second chain.  
**(With 2/1 reeving, the last chain link of both chains must be a vertical link!)**
- Run chain out on load side until at least approx. 250 mm remain on the loose chain side.
- Fit chain stopper on loose fall and gear side so that approx. 150 mm of the chains remain after the stopper and the stopper is around a horizontal chain link.
- Fit chain box and run chain into it.
- Fit single-fall bottom hook blocks on load side of chains or lead chains through two-fall bottom hook blocks and fasten chain ends to return sheave supports.  
**(Do not twist chain!)**

## 3 Installation

### 3.2 Installing trolley

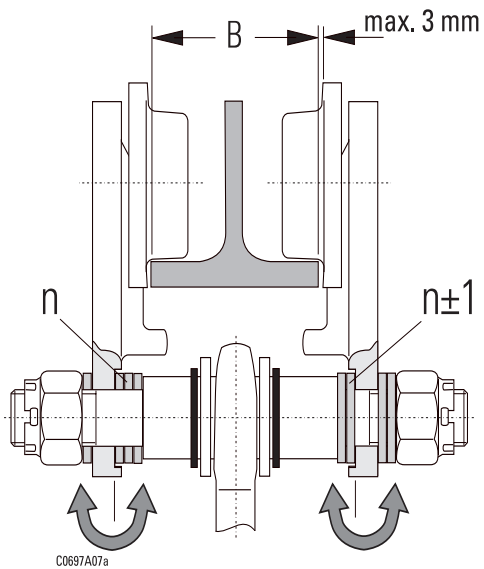

#### 3.2.1 Adjusting trolley to runway flange

1. Adjust play of wheel flanges, see sketch and table
2. Tighten nut with specified torque, see page 12
3. Fit screw retentions.

Suspend the chain hoist in the centre of the trolley.  
Grease wheel gearing.

Use only original spare parts for modifying the flange width.

- STD10/30/50/60
- Mount return sheave supports on trolleys.
- Fit spacer plates between trolleys to return sheave supports with the necessary reinforcements.
- Install chain hoist.
- Continue as described for stationary version.

## 6 Maintenance

### 6.1 Checking load chain

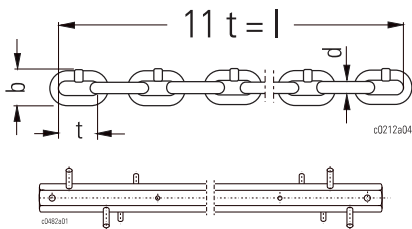

Chain gauge (Part-No. 14 320 00 65 0)

- Operate chain hoist under load. If loud clicking noises can be heard, inspect chain, chain sprocket and return sheaves for lubrication and wear.
- Check chain dimensions, measure length of chain over 11 links. The chain dimensions must not exceed the values given in the table opposite.
- If abrasion is detected, or if the limit values are no longer maintained, the chain must be replaced immediately, see "Replacing load chain".

	STD 05	STD 10	STD 30	STD 50/STD60
dxt	4x12	5x16	7x21,9	9x27
d	3,6	4,5	6,3	8,1
t	12,5	16,7	22,8	28,2
b	13,5	17	24,2	30,4
l	134,4	179,2	245,3	302,5

### 6.2 Replacing load chains

#### STD 05

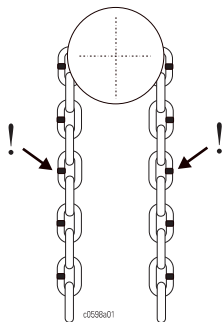
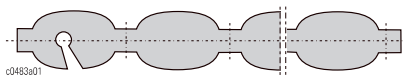

"E"

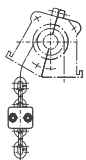

"Z"

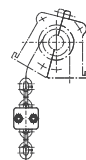

- Remove bottom hook blocks.
- Run load chains out of hoist.
- Replace chain drive.
- Insert new chain into pull-in device (Part no. 32 324 00 99 0-4).
- The welds of the links vertical to the chain sprocket must point to the outside (!).
- On the load side, push the pull-in device over the chain sprocket into the chain guide as far as it will go. Run both chains into the hoist simultaneously with inching motion, at the same time continuing to push the pull-in device in.
- Let the new chains run into the chain hoist until they project approx. 200 mm on the side which will later not be under load (chain box side).
- Fit the chain stopper in the tenth link of the chain fall on the gear side.
- On the load side insert the chain into the return sheave supports and fit bottom hook blocks. Do not twist the chain when attaching it to the chain anchorage! **With two-fall reeving, if the chain fixing bolt should be deformed or slightly worn, it must be replaced without fail.**
- The chains must run straight into the chain box from the chain guide. They must not be placed in the box by hand.

**Each chain fall may only be loaded with the permissible load; i.e. half the total S.W.L. of the chain hoist!**

## 6 Maintenance

### 6.2 Replacing load chains (continued)

STD10.../STD30.../STD50.../STD60..

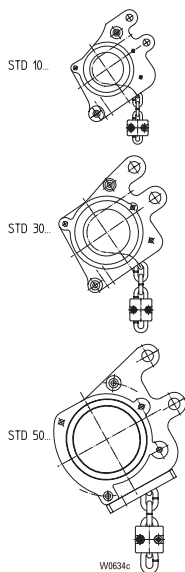

- Remove bottom hook blocks.
- Run load chains out of hoist.
- Check chain drive.
- Run longer chain into chain guide on loose chain and gear side at slow speed.  
**Caution: danger of injury!**
- Run chain over sheaves in both return sheave supports.  
**(Do not twist chain!)**
- Run vertical link of second chain with into free opening of chain guide on loose fall side at slow speed.  
**Danger of injury!**
- Lead chain over chain sheave in first chain sheave support.  
**(Do not twist chain!)**
- With the chain taut, shorten the chain end of the load side of the first chain to the same distance from the lower edge of the chain sheave support as the second chain.  
**(With 2/1 reeving, the last chain link of both chains must be a vertical link!)**
- Run chain out on load side until at least approx. 250 mm remain on the loose chain side.
- Fit chain stopper on loose fall and gear side so that approx. 150 mm of the chains remain after the stopper and the stopper is around a horizontal chain link.
- Fit chain box and run chain into it.
- Fit single-fall bottom hook blocks on load side of chains or lead chains through two-fall bottom hook blocks and fasten chain ends to return sheave supports.  
**(Do not twist chain!)**

**Each chain fall may only be loaded with the permissible load; i.e. half the total S.W.L. of the chain hoist!**

#### Lubricants

see Operating instructions for ST chain hoists

In addition, the bearing points of the return sheaves (1) are to be lubricated once a year:

Grease KP 1 K, soap base, lithium + MoS<sub>2</sub>, dripping point approx. +185 °C, penetration 310-340, operating temperature -20 °C to +120 °C,

e.g.:  
Aral Grease P 64037\*, Aral Aralub PMD 1\*, BP Multi-purpose grease M L 21 M, Esso Multi-purpose grease, Shell Retimax AM, DEA Molytex Grease EP, Fuchs Renolit FLM2\*

(Grease KPF 2 N to -30 °C, penetration 265-295, e.g. Fuchs Renolith FLM 2)

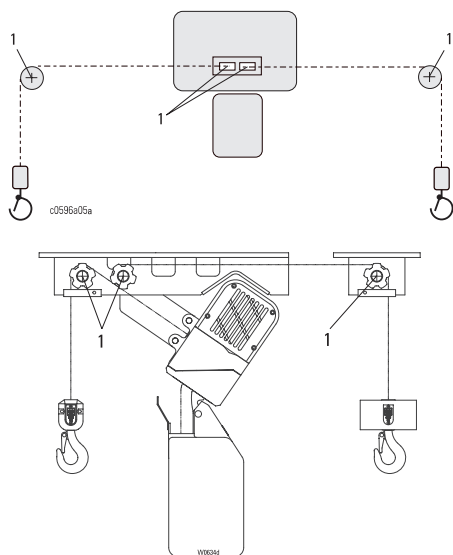

\* Factory filling  
( ) For low temperatures



## 8 Wearing parts

The list of wearing parts comprises those parts which are subject to natural wear.

When ordering, please state:

- Type and serial number of the chain hoist
- Designation and number of the parts.

### STD05

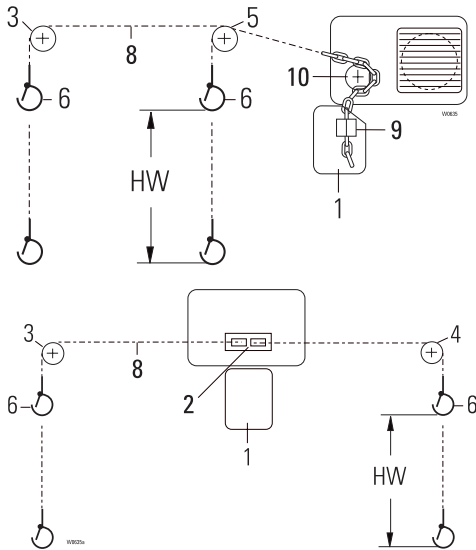

### STD10.../STD30.../STD50.../STD60...

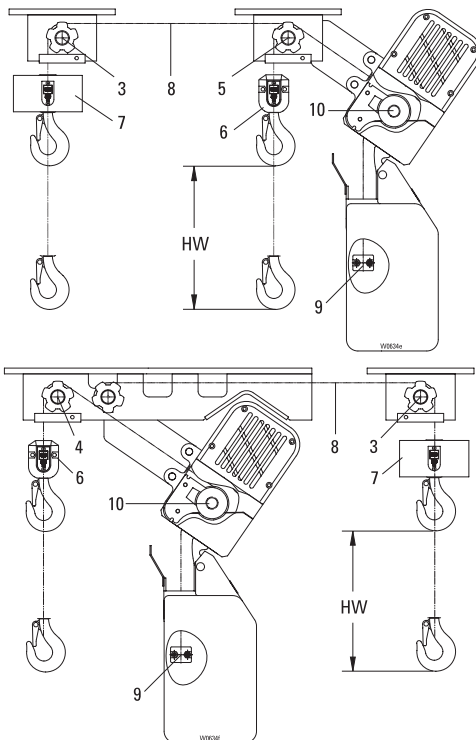

*1	Order no.			
	STD 05...	STD 10...	STD 30...	STD50.../STD60...
1	*2 2x3.5m: 32 320 56 26 0 2x7.5m: 32 320 27 26 0 2x10m: 32 320 58 26 0	*2 2x4m: 33 322 06 32 0 2x9m: 33 320 26 26 0 2x13m: 33 320 27 26 0	*2 2x4m: 33 322 06 32 0 2x6m: 33 320 26 26 0 2x8m: 33 320 27 26 0	*2 2x10m: 18 322 01 32 0 2x25m: 18 322 02 32 0 2x40m: 18 322 03 32 0
	2	"Z" 32 320 50 25 0	-	-
	3	2/2-2: 32 320 48 25 0 4/2-2: 32 320 49 25 0	14 320 11 25 0	13 320 11 25 0
4	2/2-2: 32 320 44 25 0 4/2-2: 32 320 45 25 0	14 320 12 25 0	13 320 12 25 0	18 320 12 25 0
5	2/2-2: 32 320 46 25 0 4/2-2: 32 320 47 25 0	14 320 10 25 0	13 320 10 25 0	18 320 10 25 0
6	2/2-2: (63 kg) 32 320 11 59 0 (125 kg) 32 320 05 59 0 4/2-2: (250 kg) 32 320 01 50 0	2/2-2 14 320 00 59 0 4/2-2 14 320 00 50 0	2/2-2 16 320 02 59 0 4/2-2 16 320 03 50 0	2/2-2 17 320 00 59 0 4/2-2 17 320 01 50 0
	7	-	2/2-2 14 320 02 59 0 4/2-2 14 320 02 50 0	2/2-2 16 320 03 59 0 4/2-2 16 320 04 50 0
	8	331 005 9	331 006 9	331 001 9
9	32 320 01 27 0	14 320 01 27 0	16 320 01 27 0	17 320 00 27 0
10	32 320 50 30 0 *3 32 320 51 30 0 *4	14 320 02 41 0	13 320 02 41 0	18 320 06 64 0

\*1 Item number

- 1 Chain box
- 2 Return sheave support
- 3 Return sheave support
- 4 Return sheave support
- 5 Return sheave support
- 6 Bottom hook block
- 7 Bottom hook block
- 8 Chain
- 9 Chain stopper
- 10 Chain drive

\*2 Hook path on 2/2-2, on 4/2-2: Hook path X 0.5

\*3 E: stationary + with trolley

Z: stationary

\*4 Z: with trolley

# 11 Off-standard equipment

## 11.1 Lever-type hoist limit switch

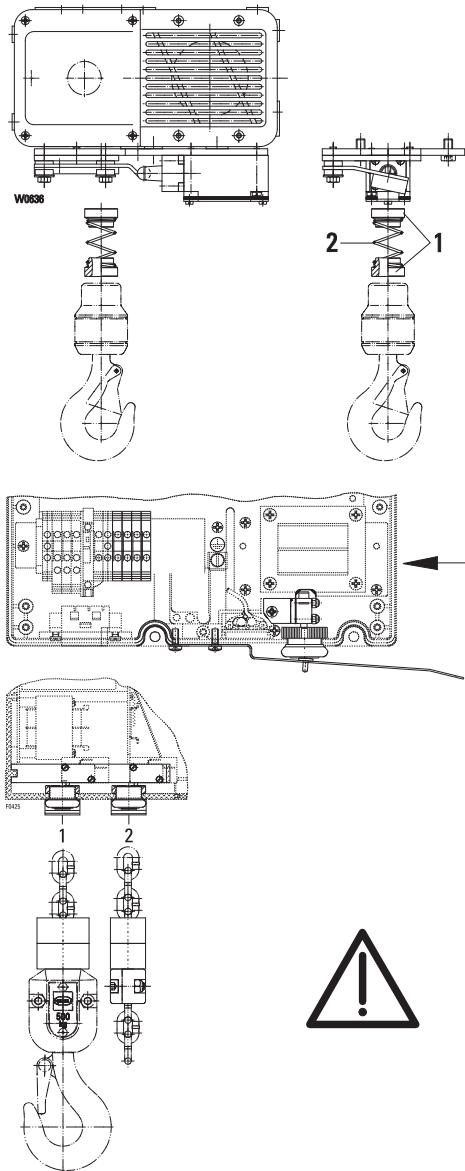

The hoist limit switch limits the highest and lowest hook positions. It can be used as an **operational limit switch**.

The slipping clutch integrated into the chain hoist takes on the function of **emergency limit switch**.

### Method of functioning on ST05

The chain hoist is switched off in highest hook position by a limit switch which is activated by the bottom hook block via pressure springs and a lever. Only lowering motion is then possible.

### Method of functioning on ST10 - ST60

In highest hook position, the microswitch is activated by the contact plate (1) and the hoisting movement is disconnected.

In the lowest hook position, the microswitch is activated by the contact plate (2) and the lowering movement is disconnected.

From highest hook position, only lowering is possible, from lowest hook position only lifting.

### Commissioning

- Check function of hoist limit switch (see Maintenance work).
- Check function of emergency limit switch (slipping clutch) (see Maintenance work).

### Maintenance intervals

#### Every day

- Check function of hoist limit switch (see Maintenance work)

#### Every year

- Visual inspection of sealing lips of microswitch
- Check function of emergency limit switch (slipping clutch) (see Maintenance work)

# 11 Off-standard equipment

## 11.1.1 Maintenance work

### Test hoist limit switch

Press the up button on the control pendant. The hoisting motion must be disconnected in top hook position. The hoist motor stands still.

Press the down button on the control pendant. The lowering motion must be disconnected in bottom hook position. The hoist motor stands still.

### Check slipping clutch as emergency limit switch

The slipping clutch which takes on the function of emergency limit switch can be tested in top and bottom hook position. To do so, the hoist limit switch must be put out of action:

1. Bridge hoist limit switch electrically (see circuit diagram).
2. Move up to top and bottom positions until slipping clutch slips. (Can be seen from the load hook standing still while the motor continues to rotate).

**Let the slipping clutch slip for a maximum of 3 seconds!**

### ST05

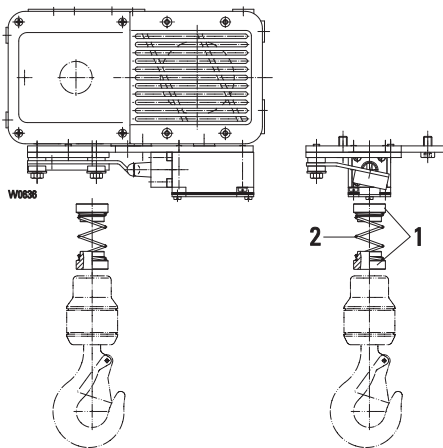

## 11.1.2 Wearing parts

How to order

- State type and serial number of your chain hoist, see rating plate.
- State designation and part number.

### ST05

- |                   |                |
|-------------------|----------------|
| 1 Guide sleeve    | 32 322 00 50 0 |
| 2 Pressure spring | 562 959 0      |

### ST10 - ST60

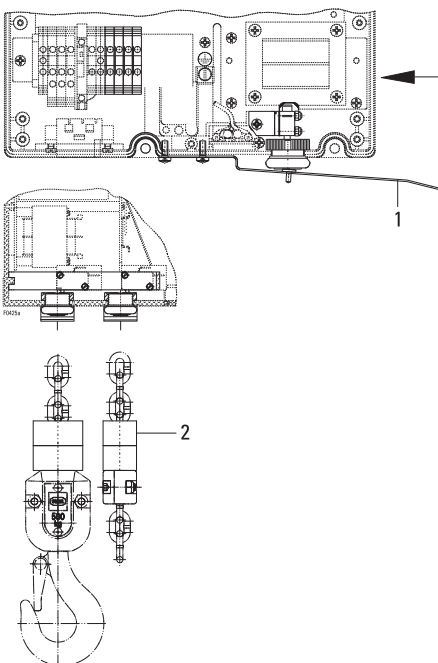

Two guide sleeves are required with each pressure spring; please order accordingly.

When replacing the pressure springs please note the information given in the ST operating instructions "Replacing load chain".

### ST10 - ST60

- |                 |                |
|-----------------|----------------|
| 1 Contact plate |                |
| ST10            | 14 329 00 71 0 |
| ST20            | 16 329 00 71 0 |
| ST30            | 16 329 00 71 0 |
| ST32/ST50       | 18 327 00 71 0 |
| 2 Buffer        |                |
| ST10            | 14 324 00 22 0 |
| ST20            | 16 324 01 22 0 |
| ST30            | 13 324 00 22 0 |
| ST32            | 17 324 00 22 0 |
| ST50            | 18 324 00 22 0 |

# 11 Off-standard equipment

## 11.2 Gear limit switch

ST05 - ST60

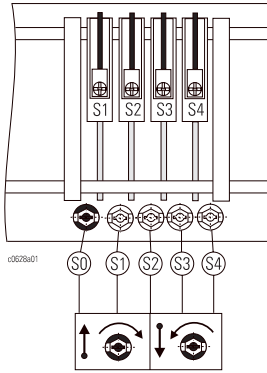

### Safety notes

The limit switch is constructed according to the state of the art and is safe in operation. However dangers may arise if it is used incorrectly and not for its intended purpose.

### Adjusting limit switch

In order to set the contacts, the cover of the limit switch must be removed. This exposes live contact connections. **There is thus a danger of contact with live parts!**

The limit switch can be adjusted at the setscrews (S1) ... (S8) (depending on the number of switching elements):

Turning to the left: switching point is moved "downwards",  
Turning to the right: switching point is moved "upwards".

### Adjusting en bloc

All the cam discs can be moved together with the aid of the black setscrew (S0). The settings of the individual contacts relative to one another remain unchanged.

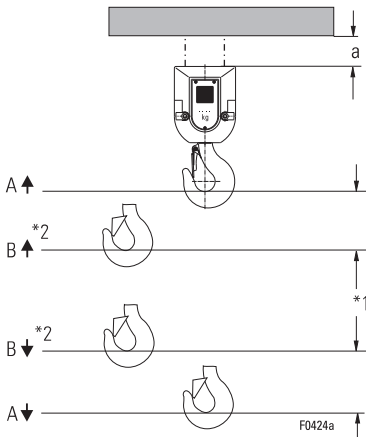

### Testing operational limit switch

- Test at fast and creep speed without load.
1. Activate the **"up" button** on the control pendant carefully, observing the hoisting motion, until the limit switch switches off in top hook position (A↑).
  2. Minimum clearance "a" between bottom hook block and nearest obstacle, see table, if necessary reset the limit switch, see page 13.
  3. Press the **"down" button** and check bottom hook position in the same way.

	a [mm]	
	50 Hz	60 Hz
1/1	130	150
2/1	70	80

### Testing combined operational and emergency hoist limit switch

The emergency hoist limit switch must be checked once a year. To enable this to be done, the operational limit switch must be bridged, see circuit diagram of hoist.

- The distance between the switching points for operational and emergency limit switches is set for normal operating conditions, however it can be adjusted if necessary.

**Note:** The function of emergency hoist limit switch is normally assumed by the slipping clutch installed in the hoist.

When testing, do not let the clutch slip for more than 3 seconds. (Can be seen from the load chain standing still while the motor fan rotates).



\*1 Effective hook path with operational limit switch

\*2 Option

# 11 Off-standard equipment

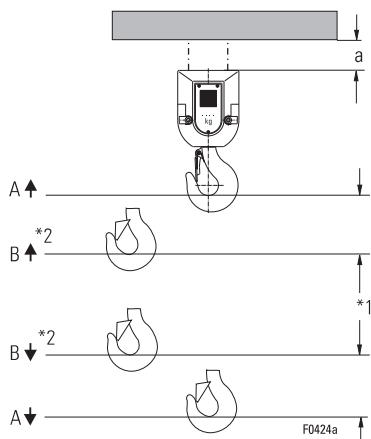

## Setting hoist limit switch

- Set the switching points in the following sequence:

### Standard control with one changeover contactor

#### Operational limit switch:

1. A↑ (S2)
2. A↓ (S1)

#### Combined operational limit switch and fast/slow switch

1. A↑ (S2)
2. B↑ (S4)
3. A↓ (S1)
4. B↓ (S3)

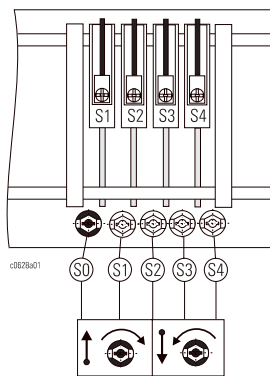

#### Switching point A↑ (S2)

"Operational limit switch top hook position"

- Lift bottom hook block 2/1 to a+10 mm (sketch, table). If necessary turn setscrew (S2) to the right beforehand.
- Turn setscrew (S2) to the left until contact S2 switches audibly.
- Check switching-off point in main and micro hoist.

	a [mm]	
	50 Hz	60 Hz
1/1	130	150
2/1	70	80

#### Switching point B↑ (S4)

fast/slow

(Minimum clearance to A↑ 60 mm for 2/1)

- Lift bottom hook block 2/1 to 10 mm below the desired switching off point, if necessary turn setscrew (S4) to the right beforehand.
- Turn setscrew (S4) to the left until contact S4 switches audibly.
- Check switching-off point in main and creep hoist.

#### Switching point A↓ (S1)

"Operational limit switch bottom hook position"

- Set bottom hook position so that the bottom hook block does not touch the ground (would cause slack chain).
- Lower bottom hook block 2/1 to 120 mm before the desired hook position, if necessary turn setscrew (S1) to the left beforehand.
- Turn setscrew (S1) to the right until contact S1 switches audibly.
- Check switching off point in main and micro hoist.

\*1 Effective hook path with operational limit switch

\*2 Option

# 11 Off-standard equipment



If the gear limit switch is used as emergency limit switch, the corresponding safety clearances for the braking path must be observed, as otherwise the hoist or the installation could be damaged.

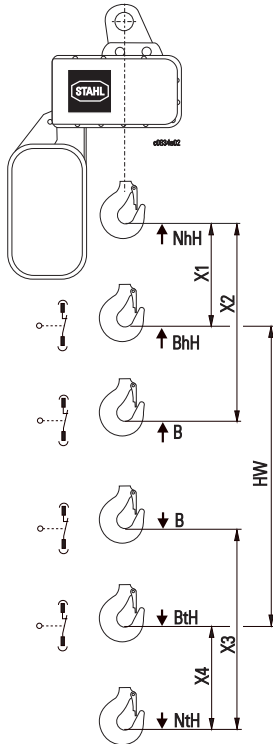

## Emergency and operational limiting (optional)

A gear limit switch disconnects the chain hoist in highest and lowest hook positions during normal operation (BhH and BtH).

With 4 contacts, there is also a fast/slow changeover (B). The switching points (B) can be selected as required.

If BhH or BtH are activated automatically at creep speed, X1 and X4 are reduced to 5 mm.

In the standard version, the **subsequent emergency limit points** (NhH and NtH) are limited by the slipping clutch. These points are only activated if the operational limit switch has not functioned.

BhH = Top hook position, operational limit switch

BtH = Bottom hook position, operational limit switch

B = Operational stop, can be set as required.

Also used for fast/slow changeover

HW = Effective hook path with operational limit switch

NhH = Top hook position, emergency limit point

NtH = Bottom hook position, emergency limit point

### 1/1 - 50 Hz:

ST 05	X1	X2	X3	X4	ST 10	X1	X2	X3	X4	ST 20	X1	X2	X3	X4	ST 30	X1	X2	X3	X4	ST 32	ST 50	ST 60	X1	X2	X3	X4
m/min	[mm]				m/min	[mm]				m/min	[mm]				m/min	[mm]				m/min	[mm]					
16	12	30	50	25	12	12	30	50	25	12	10	20	40	20	8	20	40	50	25	8			30	50	110	45

### 2/1 - 50 Hz: is half 1/1 value

### 60 Hz:

$$X1 = X1_{50\text{Hz}} \times 1,4$$

$$X2 = X2_{50\text{Hz}} \times 1,4$$

$$X3 = X3_{50\text{Hz}} \times 1,4$$

$$X4 = X4_{50\text{Hz}} \times 1,4$$

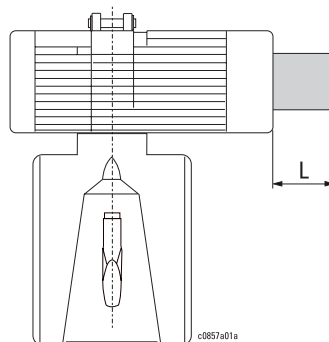

ST 05 - L = 161

ST 10 - L = 158

ST 20 - L = 158

ST 30 - L = 158

ST 32 - L = 158

ST 50 - L = 158

ST 60 - L = 158



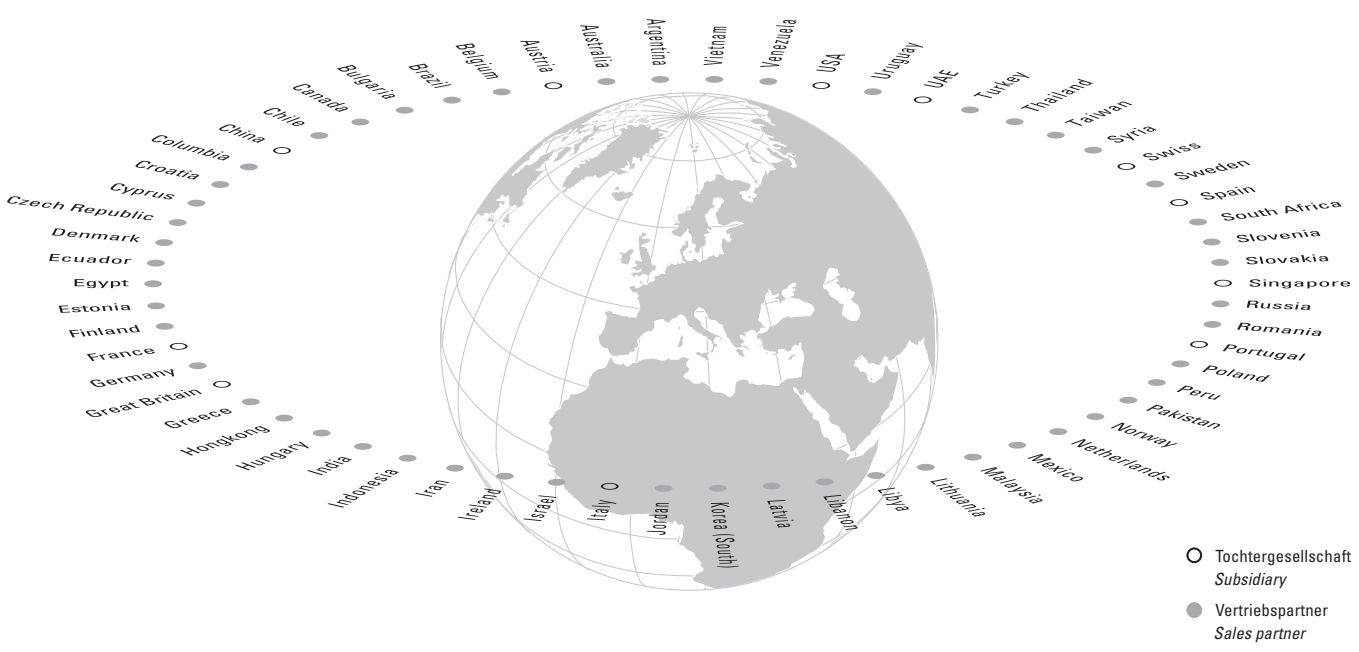

○ **Tochtergesellschaft/Subsidiary**

Austria  
Steyregg  
Tel +43 732 641111-0  
Fax +43 732 641111-33  
office@stahlcranes.at

Great Britain  
Birmingham  
Tel +44 121 7676400  
Fax +44 121 7676485  
info@stahlcranes.co.uk

Portugal  
Lissabon  
Tel +351 21 44471-60  
Fax +351 21 44471-69  
ferrometal@ferrometal.pt

Switzerland  
Däniken  
Tel +41 62 82513-80  
Fax +41 62 82513-81  
info@stahlcranes.ch

China  
Shanghai  
Tel +86 21 6257 2211  
Fax +86 21 6254 1907  
service\_cn@stahlcranes.cn

India  
Chennai  
Tel +91 44 4352-3955  
Fax +91 44 4352-3957  
indiasales@stahlcranes.in

Singapore  
Singapore  
Tel +65 6271 2220  
Fax +65 6377 1555  
sales@stahlcranes.sg

United Arab Emirates  
Dubai  
Tel +971 4 805-3700  
Fax +971 4 805-3701  
info@stahlcranes.ae

France  
Paris  
Tel +33 1 39985060  
Fax +33 1 34111818  
info@stahlcranes.fr

Italy  
S. Colombano  
Tel +39 0185 358391  
Fax +39 0185 358219  
info@stahlcranes.it

Spain  
Madrid  
Tel +34 91 484-0865  
Fax +34 91 490-5143  
info@stahlcranes.es

USA  
Charleston, SC  
Tel +1 843 767-1951  
Fax +1 843 767-4366  
sales@stahlcranes.us

● **Vertriebspartner/Sales partner**

Die Adressen von über 100 Vertriebspartnern weltweit finden Sie im Internet auf [www.stahlcranes.com](http://www.stahlcranes.com) unter Kontakt.  
You will find the addresses of over 100 sales partners on the Internet at [www.stahlcranes.com](http://www.stahlcranes.com) under Contact.

➔ [www.stahlcranes.com](http://www.stahlcranes.com)

STAHL CraneSystems GmbH, Daimlerstr. 6, 74653 Künzelsau, Germany  
Tel +49 7940 128-0, Fax +49 7940 55665, [marketing@stahlcranes.com](mailto:marketing@stahlcranes.com)

