

Krankkomponenten _

↘ DE

Originalteileliste

Crane Components_

↘ EN

Original parts list

STAHL
Crane*Systems*





Notizen
Notes

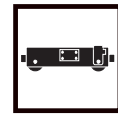

Krankopfträger		Crane endcarrige	
KEH-A080	4	KEH-A080	4
KEH-A100	6	KEH-A100	6
KEH-A125	8	KEH-A125	8
KEH-A160	10	KEH-A160	10
KEH-B080	12	KEH-B080	12
KEL-S125	13	KEL-S125	13
KEL/KZL-S160	14	KEL/KZL-S160	14
KEL/KZL-S200	15	KEL/KZL-S200	15
KEL/KZL-S315	16	KEL/KZL-S315	16
KEL/KZL-E315	17	KEL/KZL-E315	17
KZL-C400	18	KZL-C400	18
KZL-F500	19	KZL-F500	19
FE-A315	20	FE-A315	20
FE-A400	21	FE-A400	21
Fahrertriebe		Travel drives	
SU-A	22	SU-A	22
Fahrmotore SF/SA-C	24	Travel motors SF/SA-C	24
Getriebe SF.	40	Gear SF.	40
Getriebe SA-C	46	Gear SA-C	46
Drehmomentstütze	50	Torque support	50

Austausch und Reparaturen nur von geschultem Personal ausführen lassen.

Replacement and repairs may only be carried out by trained personnel.

Die Angaben in der Spalte "Benennung" dienen nur internen Vorgängen.

The information in the column "Designation" is only for internal use.

Bitte immer die Fabrik-Nr. angeben.

Please always state serial number.



Originalteile
Original parts
KEH-A080

STAHL
CraneSystems

Austausch und Reparaturen nur von geschultem Personal ausführen lassen.

Replacement and repairs may only be carried out by trained personnel.

Die Angaben in der Spalte "Benennung" dienen nur internen Vorgängen.

The information in the column "Designation" is only for internal use.

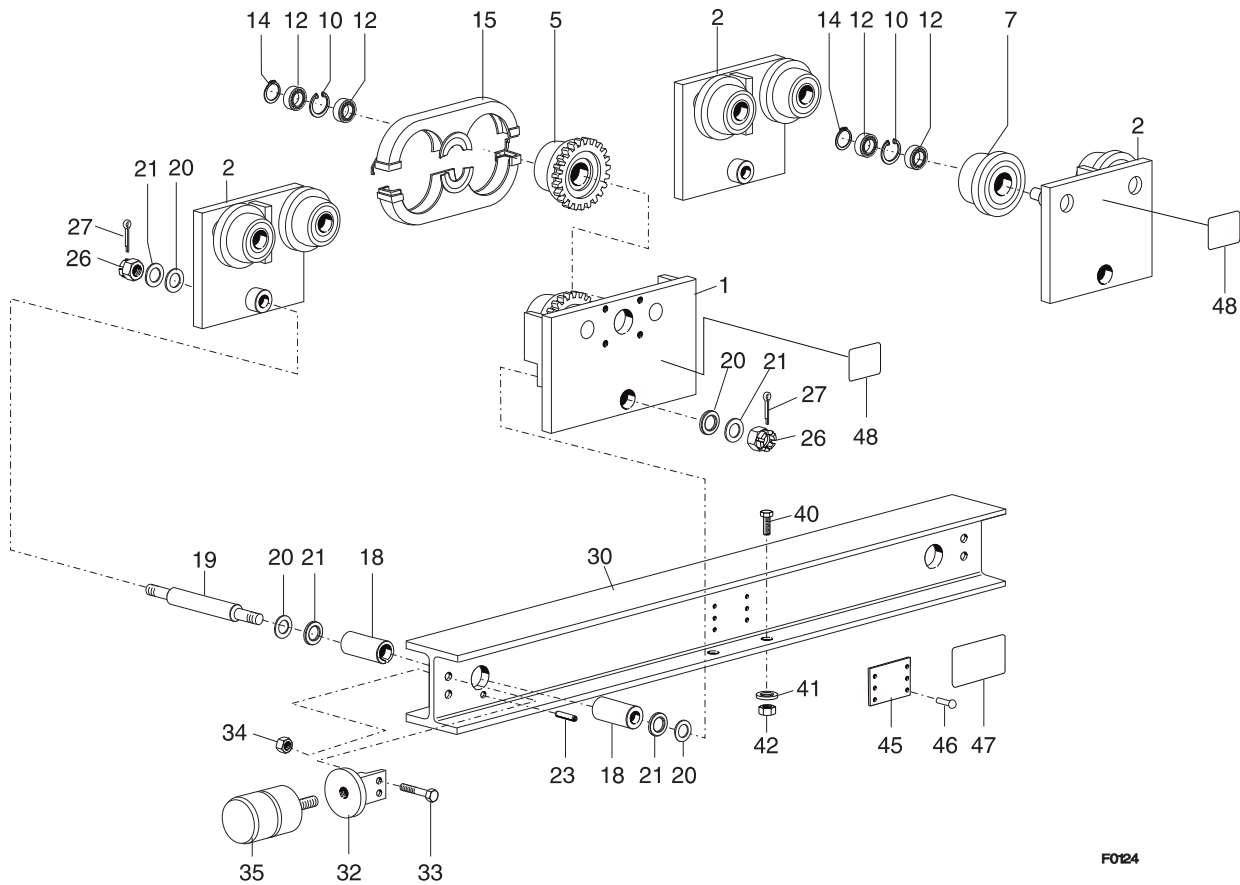

F0124

Pos	Teil-Nummer Part-Number	Stück Piece	Beschreibung Description	Benennung	Designation
1	23 720 00 25 0	1		Fahrwerkschild	Carriage side plate
2	23 720 01 25 0	3		Fahrwerkschild	Carriage side plate
5	03 250 02 40 0	2	A80 (Pos.10+12)	Laufrolle	Wheel
7	03 250 02 41 0	6	B80 (Pos.10+12)	Laufrolle	Wheel
10	506 105 0	8	42x1,75 DIN 472	Sicherungsring	Locking ring
12	560 950 0	16	6004-2RS DIN 625	Rillenkugellager	Grooved ball bearing
14	506 095 0	8	20x1,2 DIN 471	Sicherungsring	Locking ring
15	03 254 02 40 0	2		Laufrollenabdeckung	Wheel cover



Pos	Teil-Nummer Part-Number	Stück Piece	Beschreibung Description	Benennung Designation	Designation
18	23 722 07 50 0	4	55/41/25,2	Buchse	Bushing
	23 722 08 50 0	4	55/41/49,2		
	23 722 09 50 0	4	55/41/70,2		
	23 722 10 50 0	4	55/41/93,2		
	23 722 11 50 0	4	55/41/123,2		
19	23 722 06 92 0	2	73 mm - 110 mm 1)	Aufhängebolzen	Suspension bolt
	23 722 07 92 0	2	113 mm - 154 mm 1)		
	23 722 08 92 0	2	155 mm - 193 mm 1)		
	23 722 09 92 0	2	200 mm - 240 mm 1)		
	23 722 10 92 0	2	260 mm - 300 mm 1)		
20	23 722 00 52 0	8	1,5 mm	Scheibe	Disc
21	04 245 03 03 0	32	3 mm	Scheibe	Disc
23	504 082 0	2	8x30	Spannstift	Dowel pin
				ISO 8752	
26	506 917 0	4	M30x1,5	Kronenmutter	Castellated nut
27	504 061 0	4	6,3x50	Splint	Cotter pin
				DIN 935	
				DIN 94	
30	23 722 00 26 0	1	KEH-A 08010	Kopfträgerprofil	End carriage profile
	23 722 01 26 0	1	KEH-A 08018		
	23 722 02 26 0	1	KEH-A 08025		
32	23 722 01 85 0	2		Pufferbefestigung	Buffer fastening
33	500 303 0	4	M12x40	Skt-Schraube	Hexagon head cap screw
34	506 550 0	4	M12	Skt-Mutter	Hexanal nut
35	577 416 0	2		Kranpuffer	Buffer
				DIN 933-8.8	
				DIN 934	
40	501 110 0	4	M12x60	Sicherungsschraube	Locking screw
41	23 722 06 50 0	4	25/13/8	Buchse	Bushing
42	507 840 0	4	M12	Sicherungsmutter	Locking nut
45	23 720 00 80 0	1		Typenschild	Type plate
46	507 831 0	2	3x51	Blindniet	Blind rivet
				(Pos.46)	
47	23 722 01 42 0	1		Hinweisschild	Information sign
48	23 722 00 42 0	2		Hinweisschild	Information sign

1) Flanschbreite

1) Flange width



Originalteile
Original parts
KEH-A100



Austausch und Reparaturen nur von geschultem Personal ausführen lassen.

Replacement and repairs may only be carried out by trained personnel.

Die Angaben in der Spalte "Benennung" dienen nur internen Vorgängen.

The information in the column "Designation" is only for internal use.

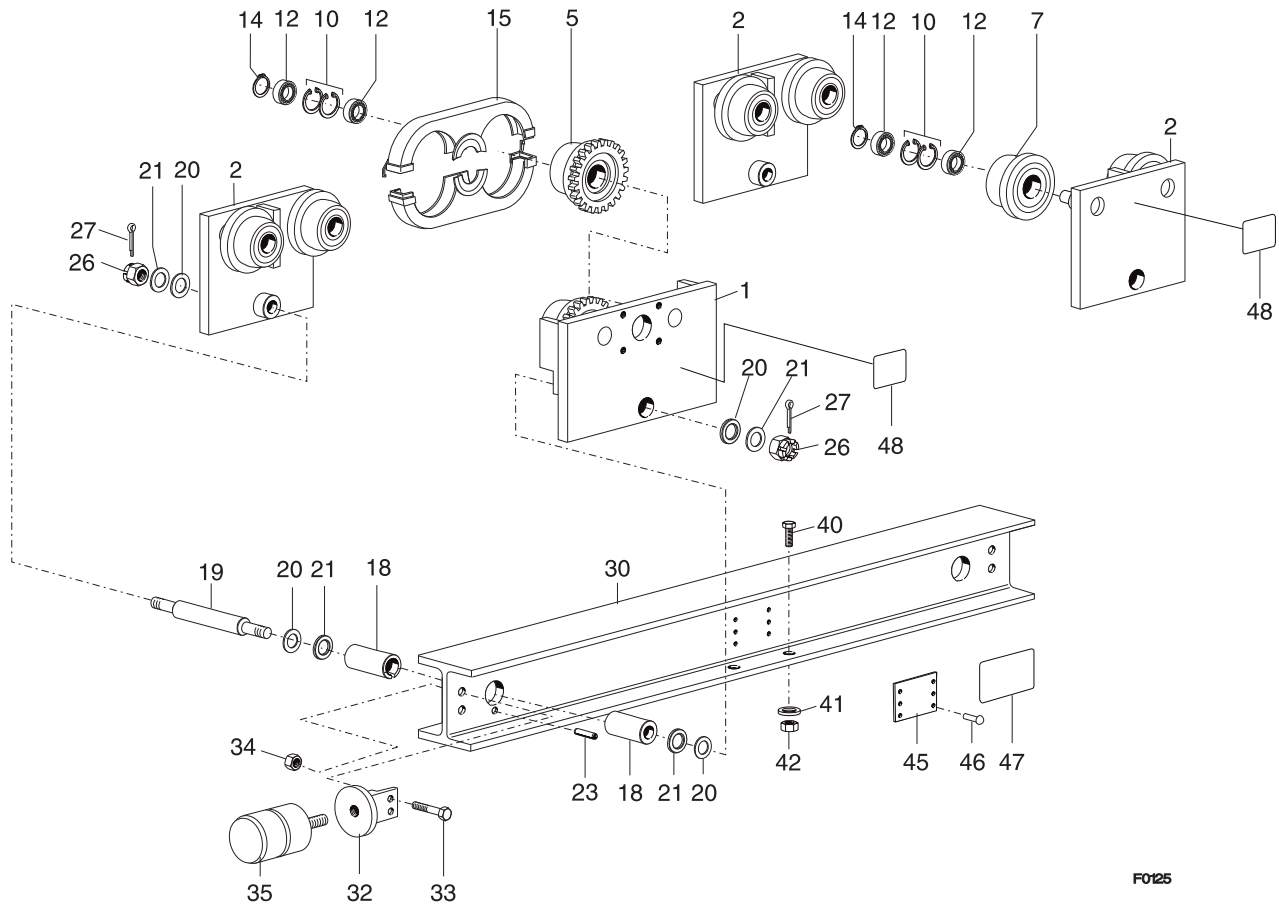

F0125

Pos	Teil-Nummer Part-Number	Stück Piece	Beschreibung Description	Benennung	Designation
1	24 720 00 25 0	1		Fahrwerkschild	Carriage side plate
2	24 720 01 25 0	3		Fahrwerkschild	Carriage side plate
5	04 250 03 40 0	2	A100	Laufrolle	Wheel
7	04 250 02 41 0	6	B100	Laufrolle	Wheel
10	506 263 0	16	55x2	Sicherungsring	Locking ring
12	560 936 0	16	6006-2Z	Rillenkugellager	Grooved ball bearing
14	506 098 0	8	30x1,5	Sicherungsring	Locking ring
15	04 254 02 40 0	2		Laufrollenabdeckung	Wheel cover

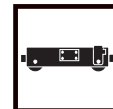

Pos	Teil-Nummer Part-Number	Stück Piece	Beschreibung Description	Benennung Designation	Designation
18	24 722 06 50 0	4	65/49/20,2	Buchse	Bushing
	24 722 07 50 0	4	65/49/44,2		
	24 722 08 50 0	4	65/49/65,2		
	24 722 09 50 0	4	65/49/88,2		
	24 722 10 50 0	4	65/49/118,2		
19	24 722 05 92 0	2	66 mm - 110 mm 1)	Aufhängebolzen	Suspension bolt
	24 722 06 92 0	2	113 mm - 154 mm 1)		
	24 722 07 92 0	2	155 mm - 193 mm 1)		
	24 722 08 92 0	2	200 mm - 240 mm 1)		
	24 722 09 92 0	2	260 mm - 300 mm 1)		
20	24 722 00 52 0	8	1,5 mm	Scheibe	Disc
21	24 722 01 52 0	32	3 mm	Scheibe	Disc
23	504 082 0	2	8x30	Spannstift	Dowel pin
				ISO 8752	
26	506 038 0	4	M36x1,5	Kronenmutter	Castellated nut
27	504 829 0	4	6,3x63	Splint	Cotter pin
				DIN 935	
				DIN 94	
30	24 722 00 26 0	1	KEH-A 10010	Kopfrägerprofil	End carriage profile
	24 722 01 26 0	1	KEH-A 10025		
32	23 722 01 85 0	2		Pufferbefestigung	Buffer fastening
33	500 303 0	4	M12x40	Skt-Schraube	Hexagon head cap screw
34	506 550 0	4	M12	Skt-Mutter	Hexanal nut
35	577 416 0	2		Kranpuffer	Buffer
				DIN 933-8.8	
				DIN 934	
40	501 111 0	4	M16x70	Sicherungsschraube	Locking screw
41	23 722 02 52 0	4	36/17/8	Buchse	Bushing
42	507 840 0	4	M16	Sicherungsmutter	Locking nut
45	23 720 00 80 0	1		Typenschild	Type plate
46	507 841 0	2	3x5	Blindniet	Blind rivet
				(Pos.46)	
47	23 722 01 42 0	1		Hinweisschild	Information sign
48	23 722 00 42 0	2		Hinweisschild	Information sign

1) Flanschbreite

1) Flange width



Originalteile
Original parts
KEH-A125



Austausch und Reparaturen nur von geschultem Personal ausführen lassen.

Replacement and repairs may only be carried out by trained personnel.

Die Angaben in der Spalte "Benennung" dienen nur internen Vorgängen.

The information in the column "Designation" is only for internal use.

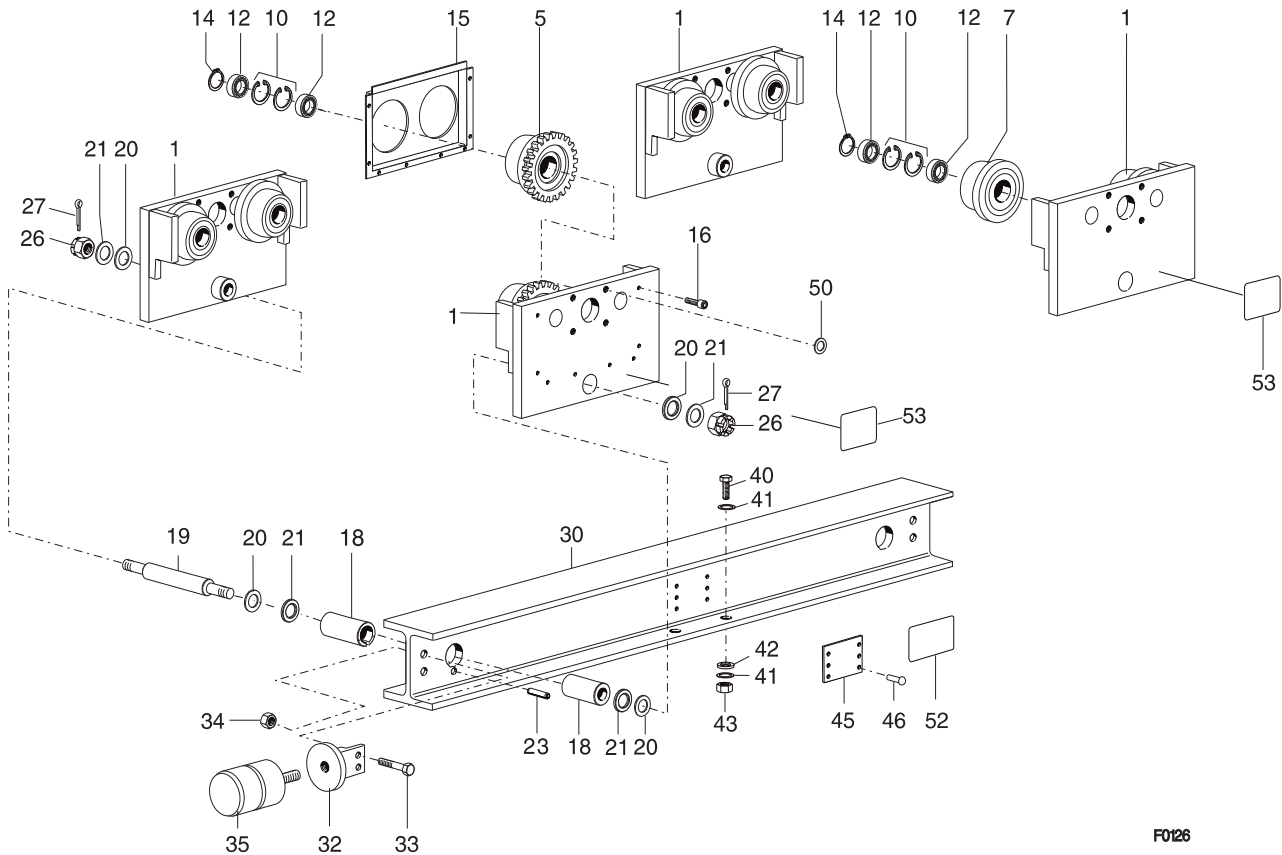

F0126

Pos	Teil-Nummer Part-Number	Stück Piece	Beschreibung Description	Benennung	Designation
1	25 720 00 25 0	4		Fahrwerkschild	Carriage side plate
5	05 250 03 40 0	2	A125	Laufrolle	Wheel
7	05 250 02 41 0	6	B125	Laufrolle	Wheel
10	506 108 0	16	62x2	Sicherungsring	Locking ring
12	560 989 0	16	6007-2Z	Rillenkugellager	Grooved ball bearing
14	506 099 0	8	35x1,5	Sicherungsring	Locking ring
15	05 254 02 40 0	1		Laufrollenabdeckung	Wheel cover
16	505 009 0	8	ST4,8x38	Blechschaube	Screw



Pos	Teil-Nummer Part-Number	Stück Piece	Beschreibung Description	Benennung	Designation
18	25 722 03 50 0	4	88,9/71,3/37,5	Buchse	Bushing
	25 722 04 50 0	4	88,9/71,3/83,5		
19	25 722 02 92 0	2	119 mm - 210 mm 1)	Aufhängebolzen	Suspension bolt
	25 722 03 92 0	2	215 mm - 300 mm 1)		
20	25 722 00 52 0	68	3 mm	Scheibe	Disc
21	25 722 01 52 0	4	7,5 mm	Scheibe	Disc
23	504 961 0	2	10x40	ISO 8750 Spannstift	Dowel pin
26	506 039 0	4	M48x1,5	DIN 935 Kronenmutter	Castellated nut
27	504 126 0	4	8x80	DIN 94 Splint	Cotter pin
30	25 722 00 26 0	1	KEH-A 125	Kopfrägerprofil	End carriage profile
32	23 722 01 85 0	2		Pufferbefestigung	Buffer fastening
33	500 303 0	4	M12x40	DIN 933-8.8 Skt-Schraube	Hexagon head cap screw
34	506 550 0	4	M12	DIN 934 Skt-Mutter	Hexanal nut
35	577 416 0	2		Kranpuffer	Buffer
40	502 966 0	4	M20x80	Skt-Schraube	Hexagon head cap screw
41	507 064 0	12	21	Scheibe	Disc
42	25 722 02 52 0	4	42/21/10	Scheibe	Disc
43	501 070 0	4	M20	Skt-Mutter	Nut
45	23 720 00 80 0	1		(Pos.46) Typenschild	Type plate
46	507 841 0	2	3x5	Blindniet	Blind rivet
50	45 342 00 52 0	4	25/11/5	Beilagscheibe	Disc
52	23 722 01 42 0	1		Hinweisschild	Information sign
53	23 722 00 42 0	2		Hinweisschild	Information sign

1) Flanschbreite

1) Flange width

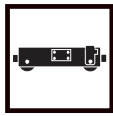

Originalteile
Original parts
KEH-A160



Austausch und Reparaturen nur von geschultem Personal ausführen lassen.

Replacement and repairs may only be carried out by trained personnel.

Die Angaben in der Spalte "Benennung" dienen nur internen Vorgängen.

The information in the column "Designation" is only for internal use.

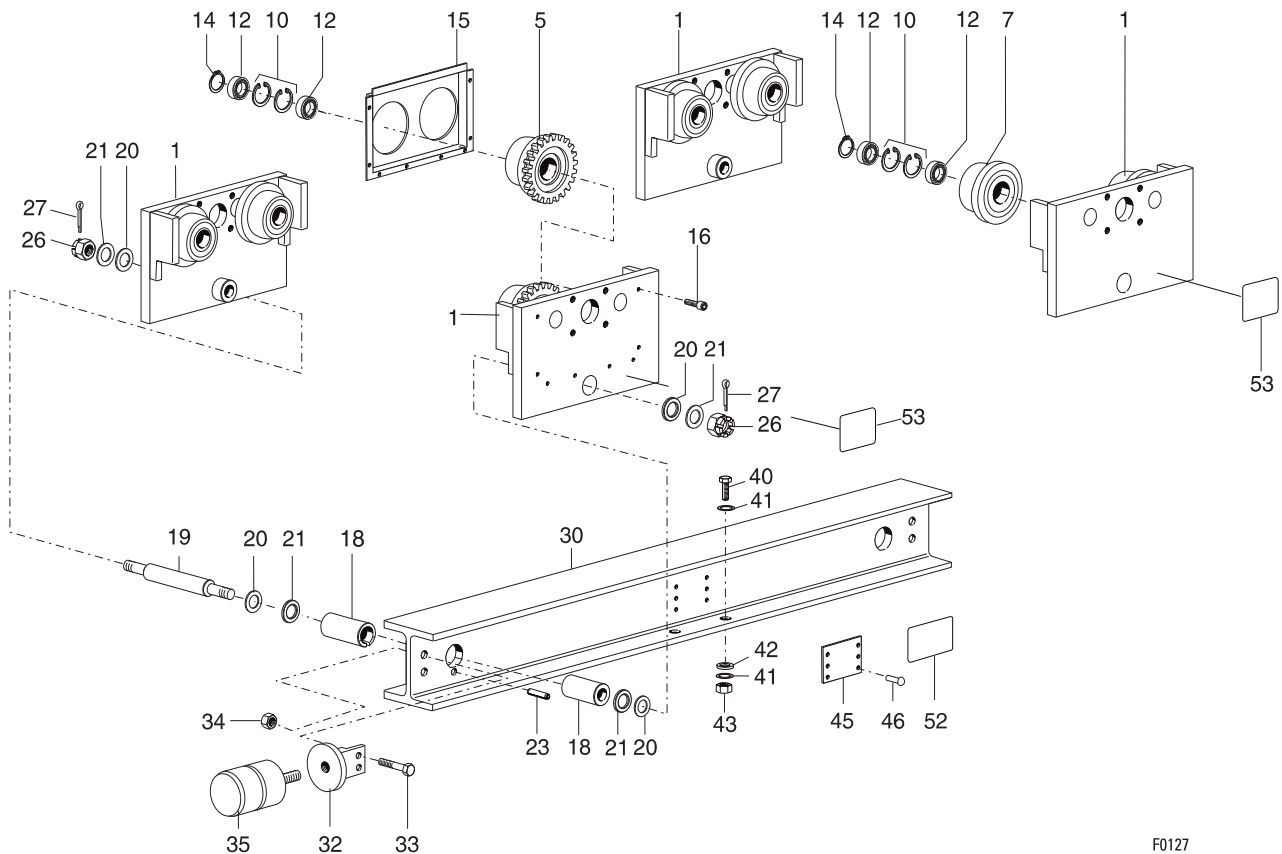

F0127

Pos	Teil-Nummer Part-Number	Stück Piece	Beschreibung Description	Benennung	Designation
1	26 720 00 25 0	4		Fahrwerkschild	Carriage side plate
5	06 250 03 40 0	2	A160	Laufrolle	Wheel
7	06 250 03 41 0	6	B160	Laufrolle	Wheel
10	506 254 0	16	80x2,5	Sicherungsring	Locking ring
12	560 005 0	16	6208-2Z	Rillenkugellager	Grooved ball bearing
14	506 247 0	8	40x1,75	Sicherungsring	Locking ring
15	06 254 04 40 0	2		Laufrollenabdeckung	Wheel cover



Pos	Teil-Nummer Part-Number	Stück Piece	Beschreibung Description	Benennung	Designation
18	26 722 03 50 0	4	88,9/71,3/37,5	Buchse	Bushing
	26 722 04 50 0	4	88,9/71,3/83,5		
19	25 722 02 92 0	2	119 mm - 210 mm 1)	Aufhängebolzen	Suspension bolt
	25 722 03 92 0	2	215 mm - 300 mm 1)		
20	25 722 00 52 0	60	3 mm	Scheibe	Disc
21	25 722 01 52 0	4	7,5 mm	Scheibe	Disc
23	504 961 0	2	10x40	Spannstift	Dowel pin
26	506 039 0	4	M48x1,5	Kronenmutter	Castellated nut
27	504 126 0	4	8x80	Splint	Cotter pin
30	26 722 00 26 0	1	KEH-A 160	Kopfträgerprofil	End carriage profile
32	23 722 01 85 0	2		Pufferbefestigung	Buffer fastening
33	500 303 0	4	M12x40	Skt-Schraube	Hexagon head cap screw
34	506 550 0	4	M12	Skt-Mutter	Hexanal nut
35	577 416 0	2		Kranpuffer	Buffer
40	502 006 0	4	M24x85	Skt-Schraube	Hexagon head cap screw
41	507 078 0	12	21	Scheibe	Disc
42	26 722 00 52 0	4	48/25/10	Scheibe	Disc
43	501 113 0	4	M24	Skt-Mutter	Nut
45	23 720 00 80 0	1		Typenschild	Type plate
46	507 841 0	2	3x5	Blindniet	Blind rivet
47	23 722 01 42 0	1		Hinweisschild	Information sign
48	23 722 00 42 0	2		Hinweisschild	Information sign

1) Flanschbreite

1) Flange width



Originalteile
Original parts
KEH-B080

STAHL
CraneSystems

Austausch und Reparaturen nur von geschultem Personal ausführen lassen.

Replacement and repairs may only be carried out by trained personnel.

Die Angaben in der Spalte "Benennung" dienen nur internen Vorgängen.

The information in the column "Designation" is only for internal use.

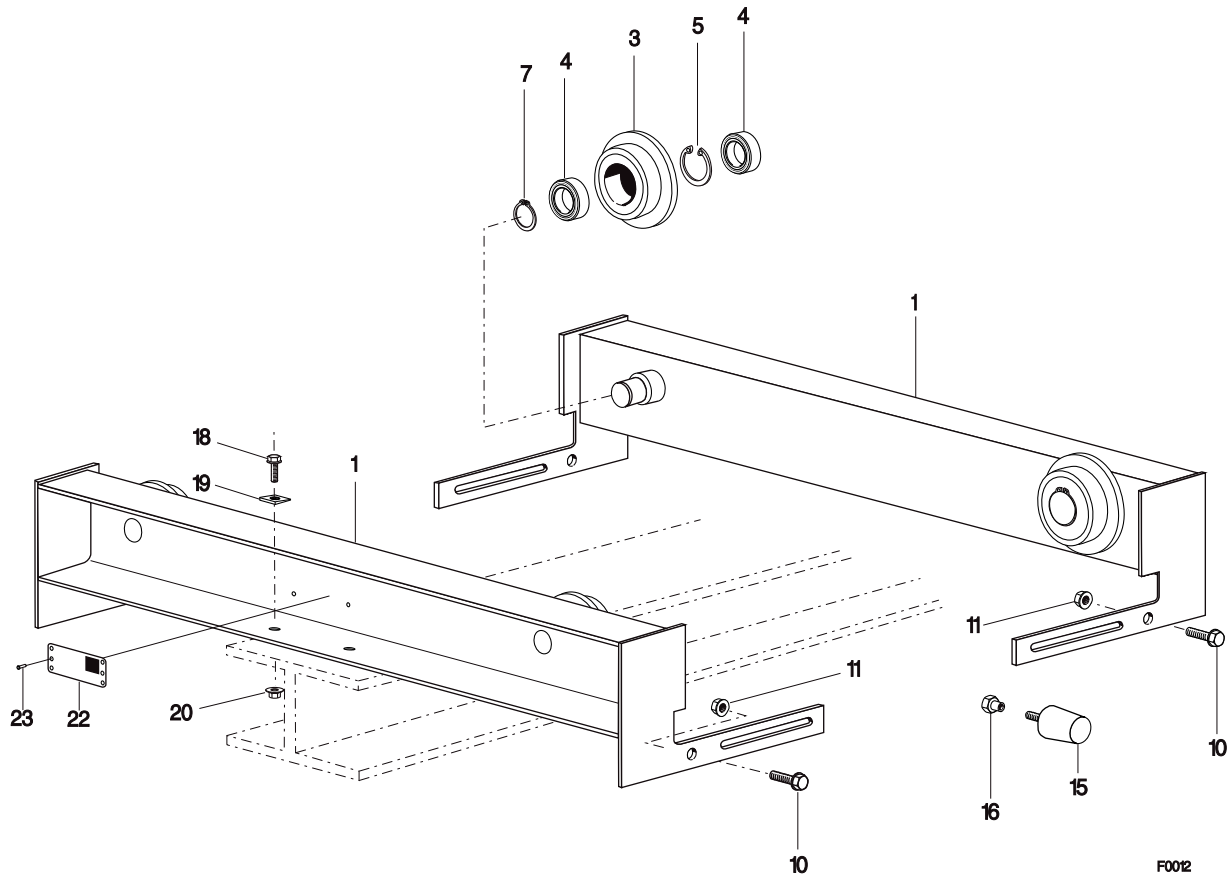

F0012

Pos	Teil-Nummer Part-Number	Stück Piece	Beschreibung Description	Benennung	Designation
1	23 720 02 25 0	2		Fahrwerkschild	Carriage side plate
3	03 250 02 41 0	4	B 80 (Pos.4+5)	Laufrolle	Wheel
4	560 950 0	8	6004-2RS DIN 625	Rillenkugellager	Grooved ball bearing
5	506 105 0	4	42x1,75 DIN 472	Sicherungsring	Locking ring
7	506 095 0	4	20x1,2 DIN 471	Sicherungsring	Locking ring
10	501 112 0	4	M12x40	Sicherungsschraube	Locking screw
11	507 840 0	4	M12	Sicherungsmutter	Locking nut
15	577 985 0	2	40No17 220	Gummipuffer	Rubber buffer
16	23 722 00 91 0	2		Mutter	Nut
18	501 112 0	4	M12x40	Sicherungsschraube	Locking screw
19	506 050 0	4	13 DIN 6918	U-Scheibe	U-Disc
20	507 840 0	4	M12	Sicherungsmutter	Locking nut
22	23 720 00 80 0	1		Typenschild	Type plate
23	507 831 0	2	3x5 (Pos.22)	Blindniet	Blind rivet

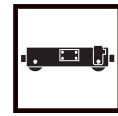

Austausch und Reparaturen nur von geschultem Personal ausführen lassen.

Replacement and repairs may only be carried out by trained personnel.

Die Angaben in der Spalte "Benennung" dienen nur internen Vorgängen.

The information in the column "Designation" is only for internal use.

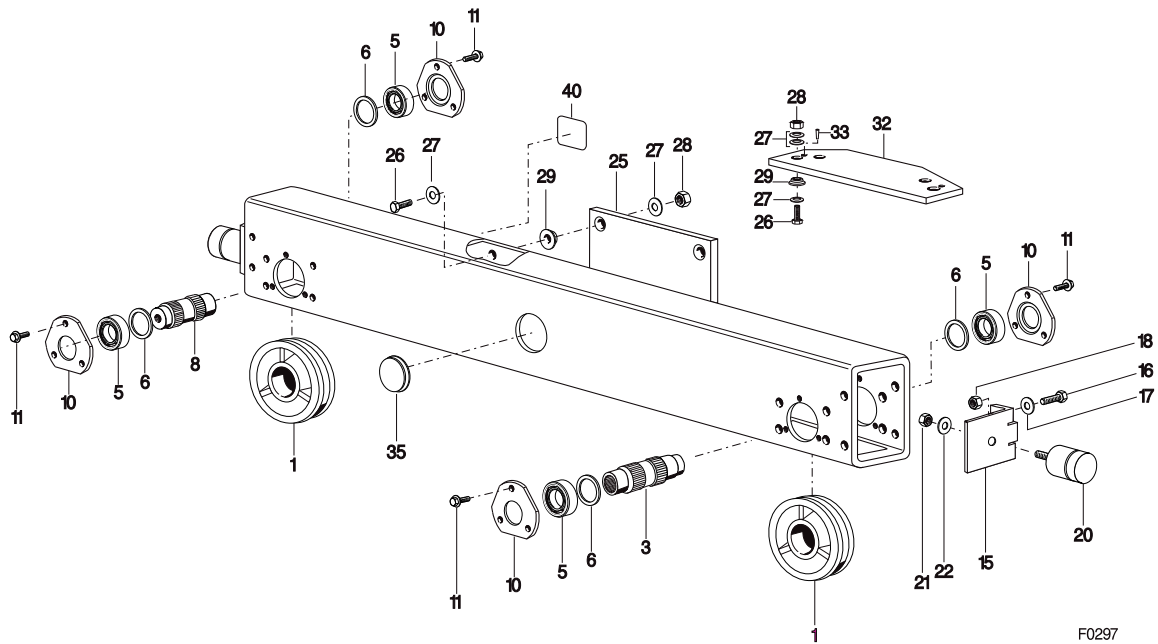

F0297

Pos	Teil-Nummer Part-Number	Stück Piece	Beschreibung Description	Benennung	Designation
1	24 254 10 01 0	2	D 125 mm *) 40 mm	Lauftrad	Travelling wheel
	24 254 11 01 0	2	D 125 mm *) 50 mm		
3	24 254 12 14 0	1		Laufradwelle	Travelling wheel shaft
5	560 005 0	4	6208-2Z DIN 625	Rillenkugellager	Grooved ball bearing
6	33 245 00 03 0	4	60/41/2	Scheibe	Disc
8	24 254 11 17 0	1		Laufradachse	Axle
10	25 712 04 58 0	4		Lagerdeckel	Bearing cover
11	501 104 0	12	M10x20-10	Sicherungsschraube	Locking screw
15	25 710 20 23 0	2		Pufferplatte	Buffer plate
16	500 334 0	4	M12x45 DIN 933	Skt-Schraube	Hexagon head cap screw
17	507 104 0	4	SKM 12	Sperrkantscheibe	Nut
18	506 828 0	4	M12	Setzmutter	Disc
20	577 416 0	2		Kranpuffer	Buffer
21	506 550 0	2	M12 DIN 934	Skt-Mutter	Hexagonal nut
22	507 104 0	2	SKM 12	Sperrkantscheibe	Disc
25	25 710 00 70 0	1		Tragplatte	Supporting plate
26	501 048 0	4	M20x75 DIN 6914	Skt-Schraube	Hexagon head cap screw
27	507 064 0	12	21	Scheibe	Disc
28	501 070 0	4	M20 DIN 6915	Skt-Mutter	Hexagonal nut
29	25 712 01 50 0	4		Buchse	Bushing
32	25 710 04 70 0	1		Tragplatte	Supporting plate
33	504 208 0	2	12x60 DIN 7978	Kegelstift	Pin
35	25 712 00 58 0	1	D 100	Deckel	Cover
40	25 712 00 46 0	1		Klebeschild	Sign

*) Schienenbreite

*) Rail width



Originalteile
Original parts
KEL/KZL-S160



Austausch und Reparaturen nur von geschultem Personal ausführen lassen.

Replacement and repairs may only be carried out by trained personnel.

Die Angaben in der Spalte "Benennung" dienen nur internen Vorgängen.

The information in the column "Designation" is only for internal use.

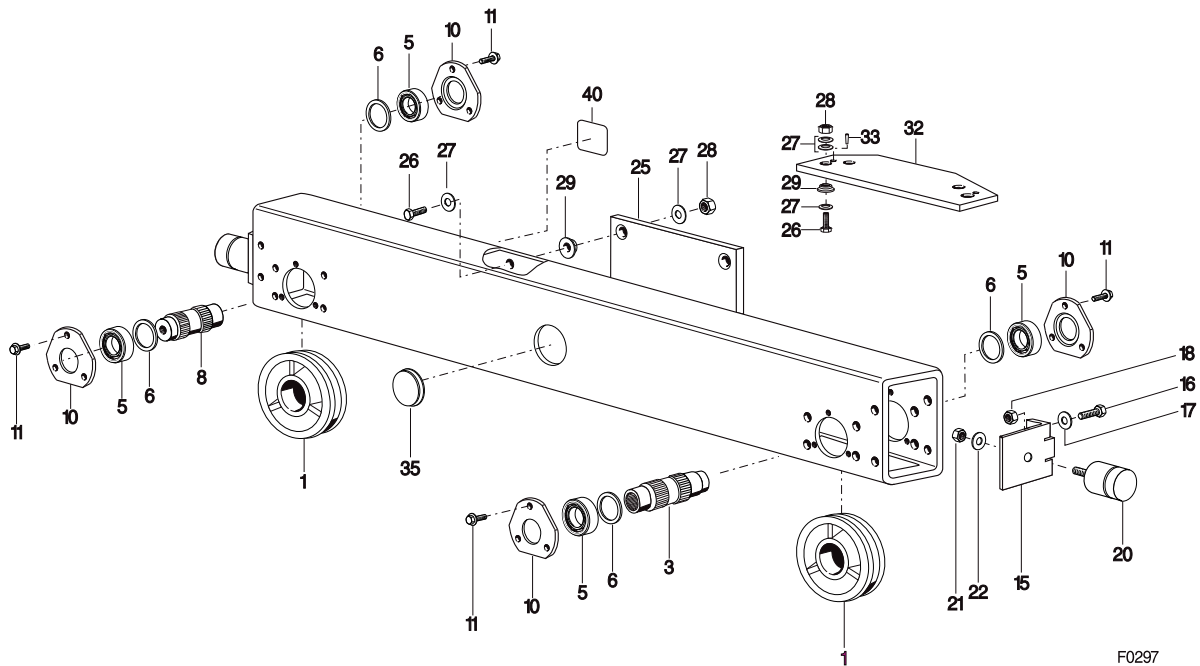

F0297

Pos	Teil-Nummer Part-Number	Stück Piece	Beschreibung Description		Benennung	Designation
1	24 254 20 01 0	2	D 160 mm	*) 40 mm	Laufgrad	Travelling wheel
	24 254 21 01 0	2	D 160 mm	*) 50 mm		
3	24 254 24 14 0	1	SF 25		Laufgradwelle	Travelling wheel shaft
5	560 979 0	4	6211-2Z	DIN 625	Rillenkugellager	Grooved ball bearing
6	26 712 00 51 0	4	70/55,5/10		Distanzring	Supporting ring
8	24 254 21 17 0	1			Laufgradachse	Axle
10	26 712 03 58 0	4			Lgerdeckel	Bearing cover
11	501 104 0	12	M10x20-10		Sicherungsschraube	Locking screw
15	25 712 01 83 0	2			Pufferplatte	Buffer plate
16	500 334 0	4	M12x45	DIN 933	Skt-Schraube	Hexagon head cap screw
17	507 104 0	4	SKM 12		Sperrkantscheibe	Disc
20	577 416 0	2			Kranpuffer	Buffer
21	506 550 0	2	M12	DIN 934	Skt-Mutter	Hexagonal nut
22	507 104 0	2	SKM 12		Sperrkantscheibe	Disc
25	26 710 00 70 0	1	KEL-S	(Pos.29)	Tragplatte	Supporting plate
	26 710 03 70 0	2	KZL-S	(Pos.29)		
26	501 048 0		M20x75	x) DIN 6914	Skt-Schraube	Hexagon head cap screw
27	507 064 0		21	x)	Scheibe	Disc
28	501 070 0		M20	x) DIN 6915	Skt-Mutter	Hexagonal nut
29	25 712 01 50 0			x)	Buchse	Bushing
32	26 710 06 70 0	1			Tragplatte	Supporting plate
33	504 208 0	2	12x60	DIN 7978	Kegelstift	Pin
35	25 712 00 58 0		D 100	x)	Deckel	Cover
43	25 712 00 46 0	1			Klebeschild	Sign

*) Schienenbreite

x) Stückzahl nach Bedarf

*) Rail width

x) Quantity as required

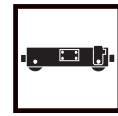

Austausch und Reparaturen nur von geschultem Personal ausführen lassen.

Replacement and repairs may only be carried out by trained personnel.

Die Angaben in der Spalte "Benennung" dienen nur internen Vorgängen.

The information in the column "Designation" is only for internal use.

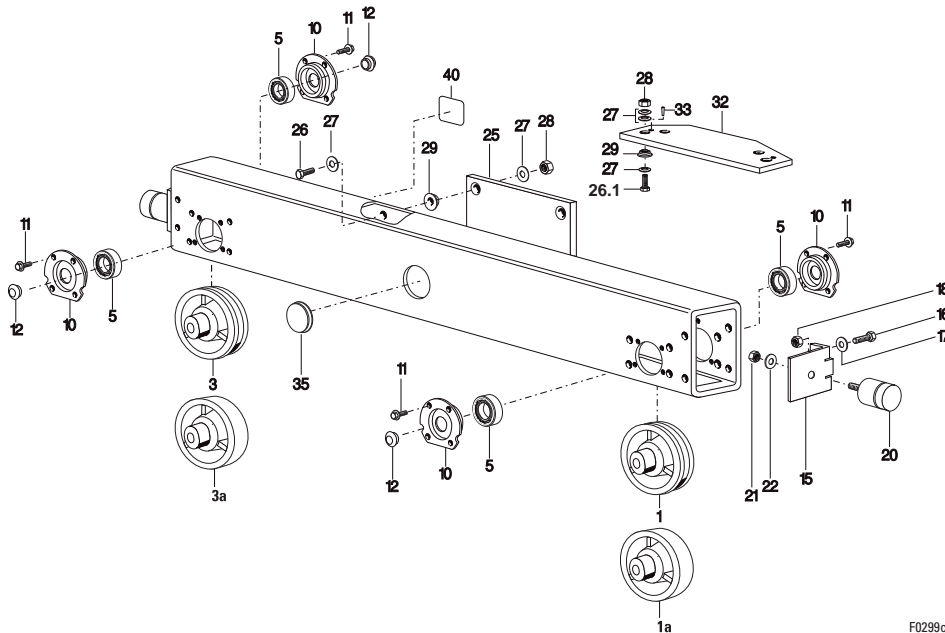

F0299c

Pos	Teil-Nummer Part-Number	Stück Piece	Beschreibung Description	Benennung Designation	Designation
1	07 257 04 01 0	1	D 200 mm *) 40 mm **)	LaufRad	Travelling wheel
	07 257 05 01 0	1	D 200 mm *) 50 mm **)		
	07 257 06 01 0	1	D 200 mm *) 60 mm **)		
1a	07 257 08 01 0	1	D 200 mm *)		
3	07 257 00 05 0	1	D 200 mm 40 mm **)	LaufRad	Travelling wheel
	07 257 01 05 0	1	D 200 mm 50 mm **)		
	07 257 02 05 0	1	D 200 mm 60 mm **)		
3a	07 257 03 05 0	1	D 200 mm		
5	560 040 0	4	6311-2Z	Rillenkugellager	Grooved ball bearing
10	27 712 03 58 0	4		Lagerflansch	Flange bearing
11	501 117 0	16	M10x30	Sicherungsschraube	Locking screw
12	515 030 0	3		Verschluß	Plug
15	27 712 01 83 0	2		Pufferplatte	Buffer plate
16	500 334 0	4		SkT-Schraube	Hexagon head cap screw
17	507 104 0	4	SKM 12	Sperrkantscheibe	Disc
18	506 828 0	4	M12	Setzmutter	Nut
20	577 417 0	2		Kranpuffer	Buffer
21	506 550 0	2	M12	SkT-Mutter	Hexagonal nut
22	507 104 0	2	SKM 12	Sperrkantscheibe	Disc
25	27 710 04 70 0	1	KEL-S (Pos.29)	Tragplatte	Supporting plate
	27 710 05 70 0	2	KZL-S 200.....36 (Pos.29)		
	27 710 06 70 0	2	KZL-S 200.....56 (Pos.29)		
26	502 966 0	4	M20x80 KEL-S	SkT-Schraube	Hexagon head cap screw
	501 048 0	8	M20x75 KZL-S		
26.1	502 967 0	4	M20x85		
27	507 064 0	21	x) DIN 6915	Scheibe	Disc
28	501 070 0	M20	x)	SkT-Mutter	Hexagonal nut
29	25 712 01 50 0		x)	Buchse	Bushing
32	27 710 11 70 0	1	(Pos.29)	Tragplatte	Supporting plate
33	504 208 0	2	12x60 ISO 8736	Kegelstift	taper pin
35	27 712 04 58 0		D 150 x)	Deckel	Cover
40	25 712 00 46 0	1		Klebeschild	Sign

*) für Antrieb

**) Schienenbreite

x) Stückzahl nach Bedarf

*) for drive

**) Rail width

x) Quantity as required



Originalteile
Original parts
KEL/KZL-S315



Austausch und Reparaturen nur von geschultem Personal ausführen lassen.

Replacement and repairs may only be carried out by trained personnel.

Die Angaben in der Spalte "Benennung" dienen nur internen Vorgängen.

The information in the column "Designation" is only for internal use.

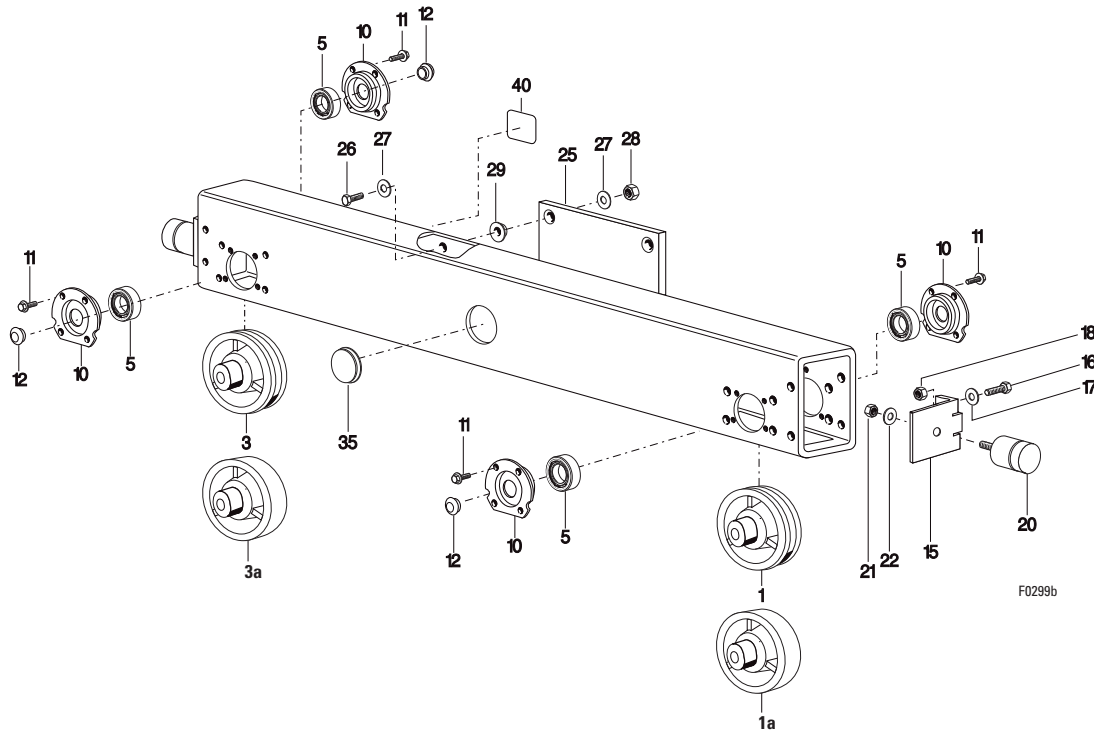

F0299b

Pos	Teil-Nummer Part-Number	Stück Piece	Beschreibung Description	Benennung Designation
1	09 257 06 01 0	1	D 315 mm *) 40 mm **)	LaufRad Travelling wheel
	09 257 07 01 0	1	D 315 mm *) 50 mm **)	
	09 257 08 01 0	1	D 315 mm *) 60 mm **)	
1a	09 257 09 01 0	1	D315 mm *)	
3	09 257 00 05 0	1	D 315 mm 40 mm **)	LaufRad Travelling wheel
	09 257 01 05 0	1	D 315 mm 50 mm **)	
	09 257 02 05 0	1	D 315 mm 60 mm **)	
3a	09 257 03 05 0	1	D 315 mm	
5	560 001 0	4	6218-2Z DIN 625	Rillenkugellager Grooved ball bearing
10	29 712 04 58 0	4		Lagerflansch Flange bearing
11	502 980 0	16	M12x30	Sicherungsschraube Locking screw
12	515 952 0	3		Verschluss Plug
15	27 712 01 83 0	2		Pufferplatte Buffer plate
16	500 334 0	4	M12x45 DIN 933	Skt-Schraube Hexagon head cap screw
17	507 104 0	4	SKM 12	Sperrkantscheibe Disc
18	506 828 0	4	M12	Setzmutter Nut
20	577 418 0	2		Kranpuffer Buffer
21	506 550 0	2	M12 DIN 934	Skt-Mutter Hexagonal nut
22	507 104 0	2	SKM 12	Sperrkantscheibe Disc
25	29 710 04 70 0	1	KEL-S (Pos.29)	Tragplatte Supporting plate
	29 710 05 70 0	2	KZL-S 315.....36 (Pos.29)	
	29 710 06 70 0	2	KZL-S 315.....56 (Pos.29)	
26	502 966 0	4	M20x80 KEL-S DIN 6914	Skt-Schraube Hexagon head cap screw
	501 048 0	12	M20x75 KZL-S DIN 6914	
27	507 064 0		x)	Scheibe Disc
28	501 070 0		21 x) DIN 6915	Skt-Mutter Hexagonal nut
29	25 712 01 50 0		M20 x)	Buchse Bushing
35	27 712 04 58 0		D 150 x)	Deckel Cover
40	25 712 00 46 0	1		Klebeschild Sign

*) für Antrieb
**) Schienenbreite
x) Stückzahl nach Bedarf

*) for drive
**) Rail width
x) Quantity as required

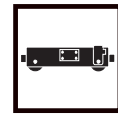

Austausch und Reparaturen nur von geschultem Personal ausführen lassen.

Replacement and repairs may only be carried out by trained personnel.

Die Angaben in der Spalte "Benennung" dienen nur internen Vorgängen.

The information in the column "Designation" is only for internal use.

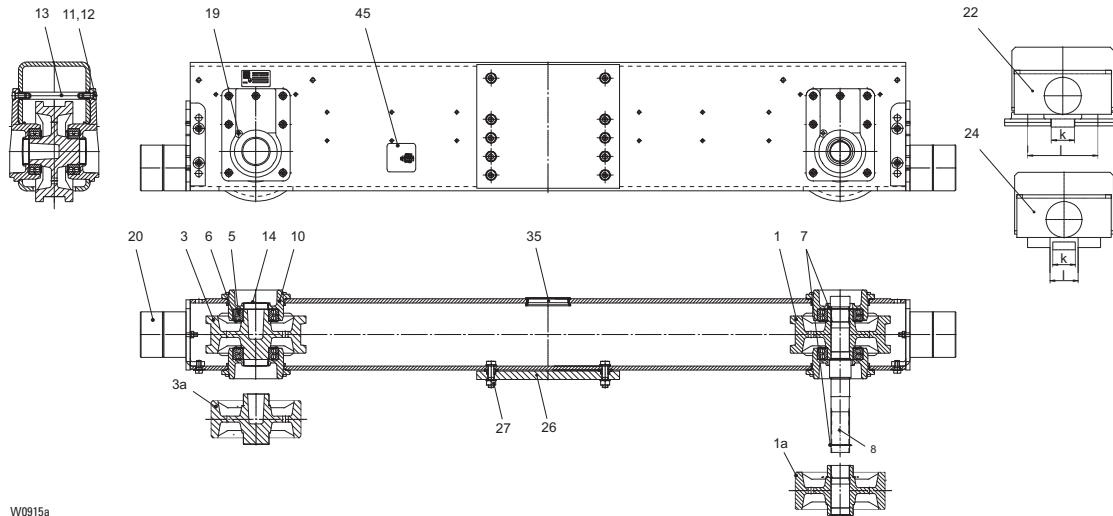

W0915a

Pos	Teil-Nummer Part-Number	Stück Piece	Beschreibung Description	Benennung	Designation
1	09 257 15 01 0	1	D 315 mm A *) 50 mm **)	Laufgrad	Travelling wheel
	09 257 16 01 0	1	D 315 mm A *) 60 mm **)		
	09 257 17 01 0	1	D 315 mm A *) 70 mm **)		
	09 257 18 01 0	1	D 315 mm A *) 80 mm **)		
	09 257 19 01 0	1	D 315 mm A *) -		
3	09 257 15 05 0	1	D 315 mm B 50 mm **)	Laufgrad	Travelling wheel
	09 257 16 05 0	1	D 315 mm B 60 mm **)		
	09 257 17 05 0	1	D 315 mm B 70 mm **)		
	09 257 18 05 0	1	D 315 mm B 80 mm **)		
	09 257 19 05 0	1	D 315 mm B -		
3a	09 257 19 05 0	1	D 315 mm B -	Pendelrollenlager	Self aligning roller bearing
5	560 808 0	4	222 18	Nilosring	Nilos ring
6	561 148 0	4		Sicherungsring	Circlip
7	506 916 0	2	65x2,5	Laufgradwelle	Travelling wheel shaft
8	09 257 02 14 0	1		Lagerflansch	Flange bearing
10	39 712 03 58 0	4		Zyl-Schraube	Socket head cap screw
11	500 812 0	28	M16x35	Sicherungsscheibe	Lock washer
12	507 001 0	28	S16	Bolzen	Bolt
13	39 712 02 92 0	2		Verschluss	Plug
14	515 107 0	2		Schmiernippel	Grease nipple
19	519 005 0	4			
20	39 710 00 23 0	2		Puffer	Buffer
22	39 710 40 31 0	1	k=50 l=253	Führungsrollenträger	Guige roller support
	39 710 08 31 0	1	k=60 l=263		
	39 710 09 31 0	1	k=70 l=273		
	39 710 10 31 0	1	k=80 l=283		
	39 710 11 31 0	1	k=100 l=303		
	39 710 12 31 0	1	k=A75 l=278		
	39 710 13 31 0	1	k=A55 l=258		
	39 710 14 31 0	1	k=A65 l=263		
	39 710 15 31 0	1	k=A100 l=303		
	39 710 18 31 0	1	k=55-75 l=100		
	39 710 19 81 0	1	K=80-100 l=125		
26	39 710 01 70 0	1	KEL-E	Tragplatte	Supporting plate
	39 710 02 70 0	2	KZL-E315.....36		
	39 710 03 70 0	2	KZL-E315.....56		
27	39 710 05 26 0	1	KEL-E	Anschluss	Connection
	39 710 04 26 0	2	KZL-E		
35	27 712 04 58 0	x		Deckel	Cap
45	25 712 01 46 0	1		Klebeschild	Sign

*) für Antrieb
**) Schienenbreite
x) Stückzahl nach Bedarf

*) for drive
**) Rail width
x) Quantity as required

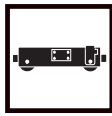

Austausch und Reparaturen nur von geschultem Personal ausführen lassen.

Replacement and repairs may only be carried out by trained personnel.

Die Angaben in der Spalte "Benennung" dienen nur internen Vorgängen.

The information in the column "Designation" is only for internal use.

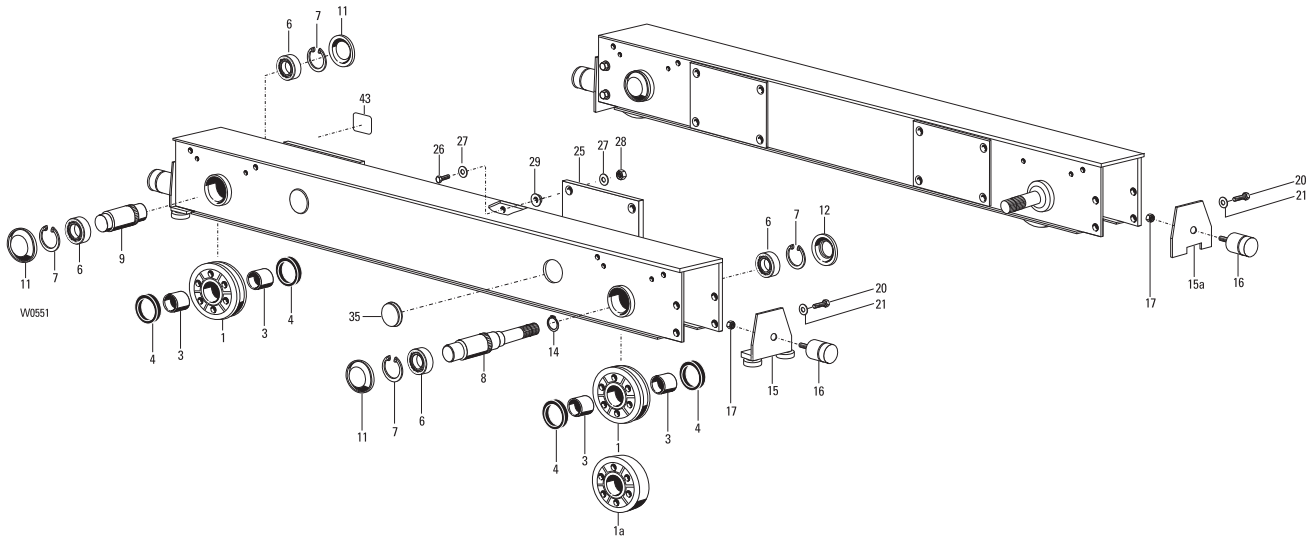

Pos	Teil-Nummer Part-Number	Stück Piece	Beschreibung Description		Benennung	Designation	
1	24 254 62 01 0	2	D 400 mm	*)	50 mm	Laufрад	Travelling wheel
	24 254 63 01 0	2	D 400 mm	*)	60 mm		
	24 254 64 01 0	2	D 400 mm	*)	70 mm		
1a	24 254 60 01 0	2	D 400 mm		Laufрад	Travelling wheel	
3	561 001 0	4			Buchse	Bushing	
4	518 303 0	4			Dichtring	Sealing ring	
6	560 808 0	4	222 18		Pendelrollenlager	Poller bearing	
7	506 922 0	4	160x4		Sicherungsring	Locking ring	
8	24 254 60 14 0	1			Laufradwelle	Travelling wheel shaft	
9	24 254 60 17 0	1			Laufradachse	Axle	
11	29 712 00 58 0	3			Verschlussdeckel	End cap	
12	29 712 01 58 0	1			Verschlussdeckel	End cap	
14	506 916 0	1	65x2,5		Sicherungsring	Locking ring	
15	30 710 00 31 0	2	50 mm	*)	(Pos.16+17)	Führungsrollenträger	Guide roller support
	30 710 01 31 0	2	60 mm	*)	(Pos.16+17)		
	30 710 02 31 0	2	70 mm	*)	(Pos.16+17)		
	30 710 03 31 0	2	100 mm	*)	(Pos.16+17)		
15a	30 710 79 31 0	2	<= 60 mm	*)	(Pos.16+17)	Entgleisungsschutz	Anti-derail device
	30 710 80 31 0	2	> 60 mm <= 100 mm	*)	(Pos.16+17)		
16	577 418 0	2			Kranpuffer	Buffer	
17	506 828 0	2	M12		Setzmutter	Nut	
20	500 919 0	8	M24x60		Skt-Schraube	Hexagon head cap screw	
21	562 000 0	8	24		Spannscheibe	Disc	
25	30 710 00 70 0	2	KZL-C 400.9.31.140		(Pos.29)	Tragplatte	Supporting plate
	30 710 02 70 0	2	KZL-C 400.5.40.140		(Pos.29)		
	30 710 02 70 0	1	KEL-C		(Pos.29)		
	30 710 01 70 0	2	KZL-C 400.....58		(Pos.29)		
26	502 978 0		M30x105	x)	DIN 6914	Skt-Schraube	Hexagon head cap screw
27	507 080 0		31	x)	DIN 6916	Scheibe	Disc
28	501 073 0		M30	x)	DIN 6915	Skt-Mutter	Hexagonal nut
29	30 712 01 50 0			x)		Buchse	Bushing
35	27 712 04 58 0	2			Deckel	Cover	
43	25 712 00 46 0	1			Klebeschild	Sign	

*) Schienenbreite
x) Stückzahl nach Bedarf

*) Rail width
x) Quantity as required

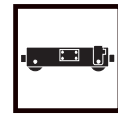

Austausch und Reparaturen nur von geschultem Personal ausführen lassen.

Replacement and repairs may only be carried out by trained personnel.

Die Angaben in der Spalte "Benennung" dienen nur internen Vorgängen.

The information in the column "Designation" is only for internal use.

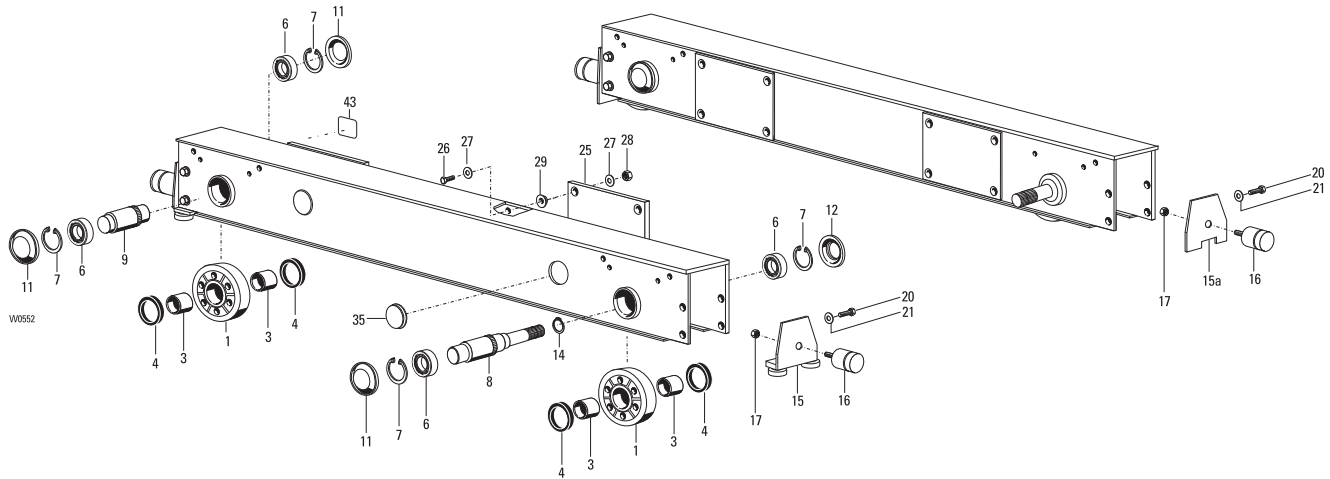

Pos	Teil-Nummer Part-Number	Stück Piece	Beschreibung Description	Benennung	Designation
1	24 254 70 01 0	2	D 500 mm	Laufrad	Travelling wheel
3	561 001 0	4		Buchse	Bushing
4	518 303 0	4		Dichtring	Sealing ring
6	560 808 0	4	222 18	Pendelrollenlager	Poller bearing
7	506 922 0	4	160x4	Sicherungsring	Locking ring
8	24 254 60 14 0	1		Laufradwelle	Travelling wheel shaft
9	24 254 60 17 0	1		Laufradachse	Axle
11	29 712 00 58 0	3		Verschußdeckel	End cap
12	29 712 01 58 0	1		Verschußdeckel	End cap
14	506 916 0	1	65x2,5	Sicherungsring	Locking ring
15	31 710 00 31 0	2	50 mm *)	Führungsrollenträger	Guide roller support
	31 710 01 31 0	2	60 mm *)		
	31 710 02 31 0	2	70 mm *)		
	31 710 03 31 0	2	100 mm *)		
15a	31 710 79 31 0	2	<=60 mm *)	Entgleisungsschutz	Anti-derail device
	31 710 80 31 0	2	>60 mm <= 100 mm *)		
16	577 419 0	2		Kranpuffer	Buffer
17	506 828 0	2	M12	Setzmutter	Nut
20	500 919 0	8	M24x60	Skt-Schraube	Hexagon head cap screw
21	562 000 0	8	24	Spannscheibe	Disc
25	31 710 00 70 0	2	KZL-F 500.....140	Tragplatte	Supporting plate
	31 710 01 70 0	2	KZL-F 500.....58		
	31 710 02 70 0	2	KZL-F 500.....578		
26	502 978 0	12	M30x105	Skt-Schraube	Hexagon head cap screw
27	507 080 0	24	31	Scheibe	Disc
28	501 073 0	12	M30	Skt-Mutter	Hexagonal nut
29	30 712 01 50 0	8		Buchse	Bushing
35	27 712 04 58 0	2		Deckel	Cover
43	25 712 00 46 0	1		Klebeschild	Sign

*) Schienenbreite

*) Rail width



Originalteile
Original parts
FE-A 315

STAHL
CraneSystems

Austausch und Reparaturen nur von geschultem Personal ausführen lassen.

Replacement and repairs may only be carried out by trained personnel.

Die Angaben in der Spalte "Benennung" dienen nur internen Vorgängen.

The information in the column "Designation" is only for internal use.

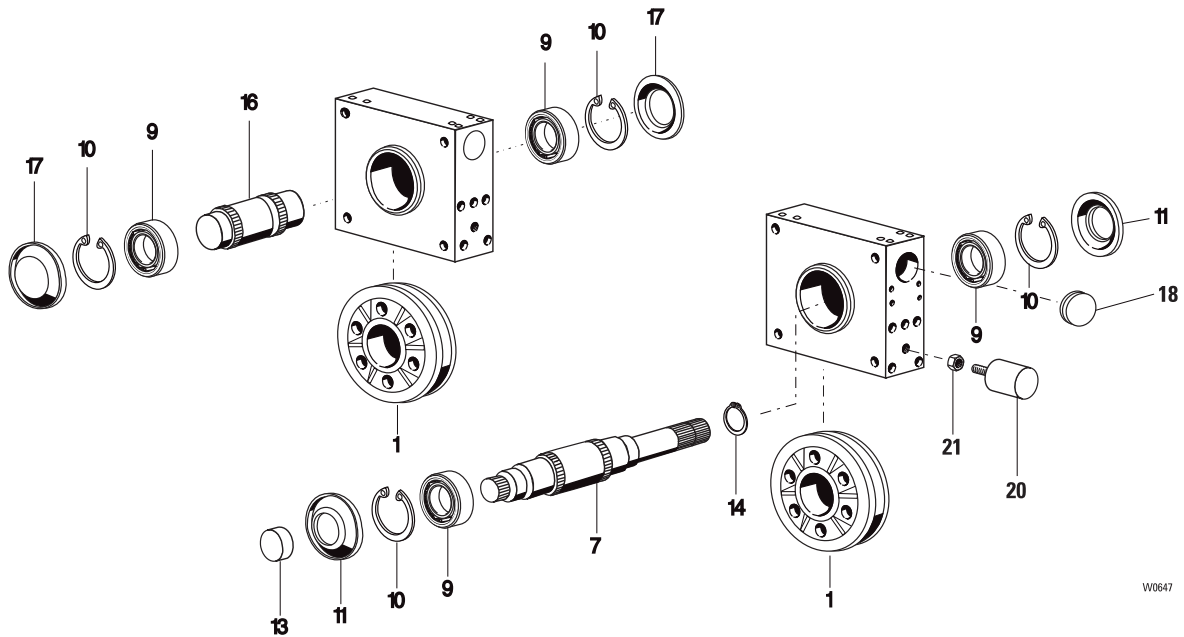

W0647

Pos	Teil-Nummer Part-Number	Stück Piece	Beschreibung Description	Benennung	Designation
1	24 254 50 01 0	4	D315 1) 40 mm	LaufRad	Wheel
	24 254 51 01 0	4	D315 1) 50 mm		
	24 254 52 01 0	4	D315 1) 60 mm		
7	24 254 51 14 0	2		LaufRadwelle	Axle
9	560 001 0	8	6218-2Z	Rillenkugellager	Grooved ball bearing
10	506 922 0	8	160x4	Sicherungsring	Locking ring
11	29 712 01 58 0	4		Verschlußdeckel	Cover
13	518 022 0	2		Schutzkappe	Protective cap
14	506 916 0	2	65x2,5	Sicherungsring	Locking ring
16	24 254 50 17 0	2		LaufRadachse	Axle
17	29 712 00 58 0	4		Verschlußdeckel	Cover
18	25 712 00 58 0	4		Deckel	over
20	577 416 0		x)	Cellasto-Kranpuffer	Buffer
21	506 550 0		x)	Skt-Mutter	Hexagonal nut

1) Schienenbreite
x) Stückzahl nach Bedarf

1) Rail width
x) Quantity as required

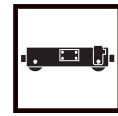

Austausch und Reparaturen nur von geschultem Personal ausführen lassen.

Replacement and repairs may only be carried out by trained personnel.

Die Angaben in der Spalte "Benennung" dienen nur internen Vorgängen.

The information in the column "Designation" is only for internal use.

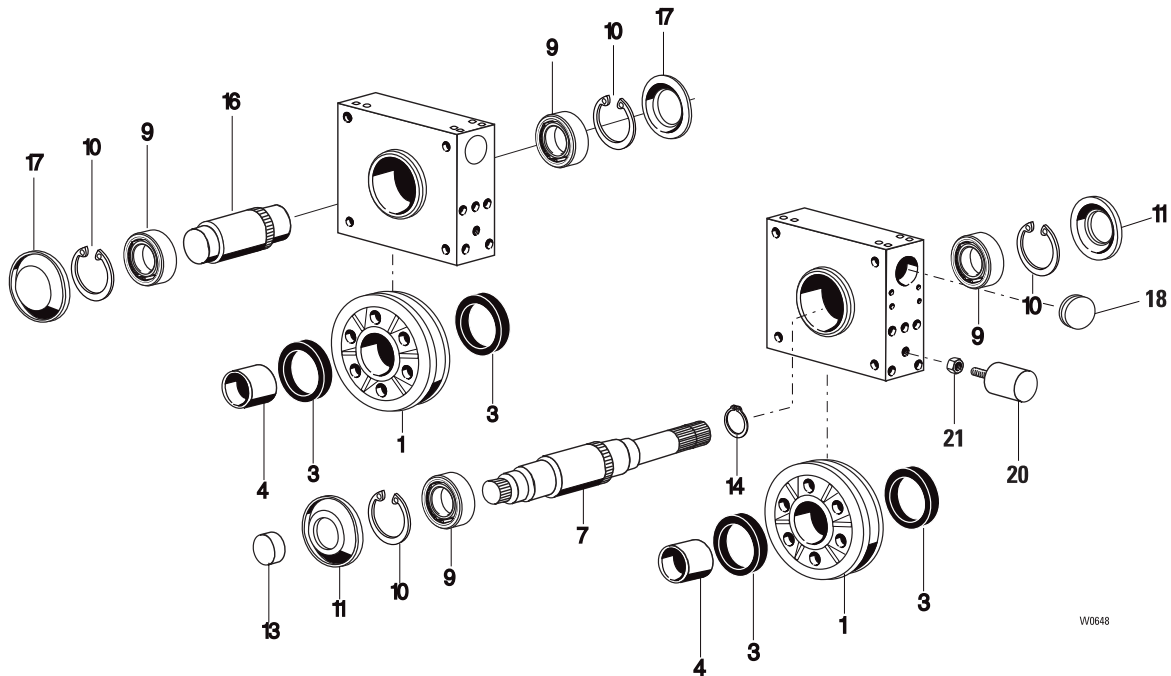

W0648

Pos	Teil-Nummer Part-Number	Stück Piece	Beschreibung Description			Benennung	Designation
1	24 254 62 01 0	4	D400	1)	50 mm	Laufрад	Wheel
	24 254 63 01 0	4	D400	1)	60 mm		
	24 254 64 01 0	4	D400	1)	70 mm		
3	518 303 0	8				Dichtring	Sealing ring
4	561 001 0	4				Buchse	Bushing
7	24 254 61 14 0	2				Laufрадwelle	Axle
9	560 808 0	8	222 18		DIN 625	Pendelrollenlager	Roller bearing
10	506 922 0	8	160x4		DIN 472	Sicherungsring	Locking ring
11	29 712 01 58 0	4				Verschlußdeckel	Cover
13	518 022 0	2				Schutzkappe	Protective cap
14	506 916 0	2	65x2,5		DIN 471	Sicherungsring	Locking ring
16	24 254 60 17 0	2				Laufradachse	Axle
17	29 712 00 58 0	4				Verschlußdeckel	Cover
18	25 712 00 58 0	4				Deckel	Cover
20	577 416 0			x)		Cellasto-Kranpuffer	Buffer
21	506 550 0			x)		Skt-Mutter	Hexagonal nut

1) Schienenbreite
x) Stückzahl nach Bedarf

1) Rail width
x) Quantity as required



Austausch und Reparaturen nur von geschultem Personal ausführen lassen.

Replacement and repairs may only be carried out by trained personnel.

Die Angaben in der Spalte "Benennung" dienen nur internen Vorgängen.

The information in the column "Designation" is only for internal use.

A 04

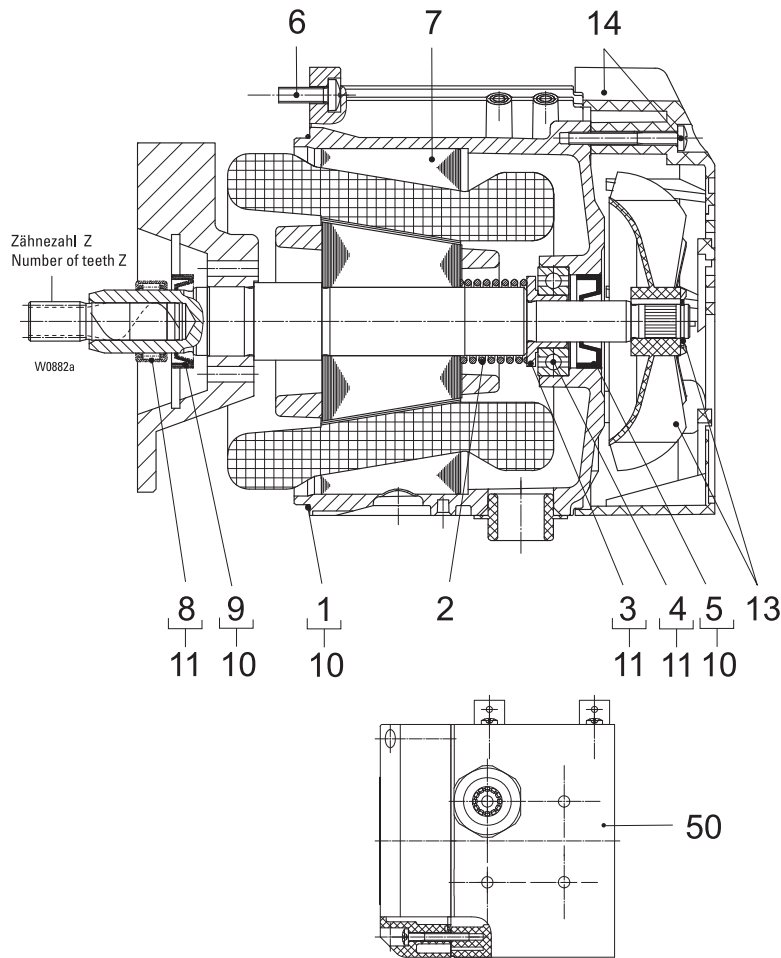

Pos	Teil-Nummer Part-Number	Stück Piece	Beschreibung Description	Benennung	Designation	
	34 330 66 11 9	1	2A04 S	1) (Pos.1-7) Z=11	Motor	Motor
	34 330 65 11 9	1	2A04 S	1) (Pos.1-7) Z=13		
	34 330 64 11 9	1	2A04 S	1) (Pos.1-7) Z=15		
	34 330 63 11 9	1	2A04 S	1) (Pos.1-7) Z=19		
	34 330 73 11 9	1	2/8A04 S	1) (Pos.1-7) Z=11		
	34 330 74 11 9	1	2/8A04 S	1) (Pos.1-7) Z=13		
	34 330 72 11 9	1	2/8A04S	1) (Pos.1-7) Z=15		
	34 330 71 11 9	1	2/8A04S	1) (Pos.1-7) Z=19		
	34 330 69 11 9	1	4/A04S	1) (Pos.1-7) Z=13		
	34 330 67 11 9	1	4/A04S	1) (Pos.1-7) Z=19		
1	1	116x1,5		Runddichtring	round sealing ring
2	34 331 01 94 0	1			Druckfeder	Pressure spring
3	1			Lagerbuchse	Bushing
4	1	6003-2RS		Rillenkugellager	Grooved ball bearing
5	1	13x30x8		Wellendichtring	Shaft seal
6	4	5x16	DIN 7500	Schraube	Screw
7	1			Sator	Stator
8	1			Nadelhülse	Needle bush
9	1	20x30x7		Wellendichtring	Shaft seal
10	34 330 00 64 0	1		(Pos.1,5,9)	Motor-Dichtung-Set	Motor seal set
11	34 330 01 64 0	1		(Pos.3,4,8)	Motor-Lager-Set	Motor bearing set
13	34 330 00 17 0	1			Lüfterrad-Set	Fan wheel set
14	34 330 00 19 0	1			Lüfterhaube-Set	Fan cowling set
50	14 320 16 91 0	1			Gerätekasten	Terminal box

1) Bitte Betriebsspannung und Frequenz angeben.

1) Please state operating voltage and frequency.

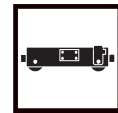

Getriebe / gear

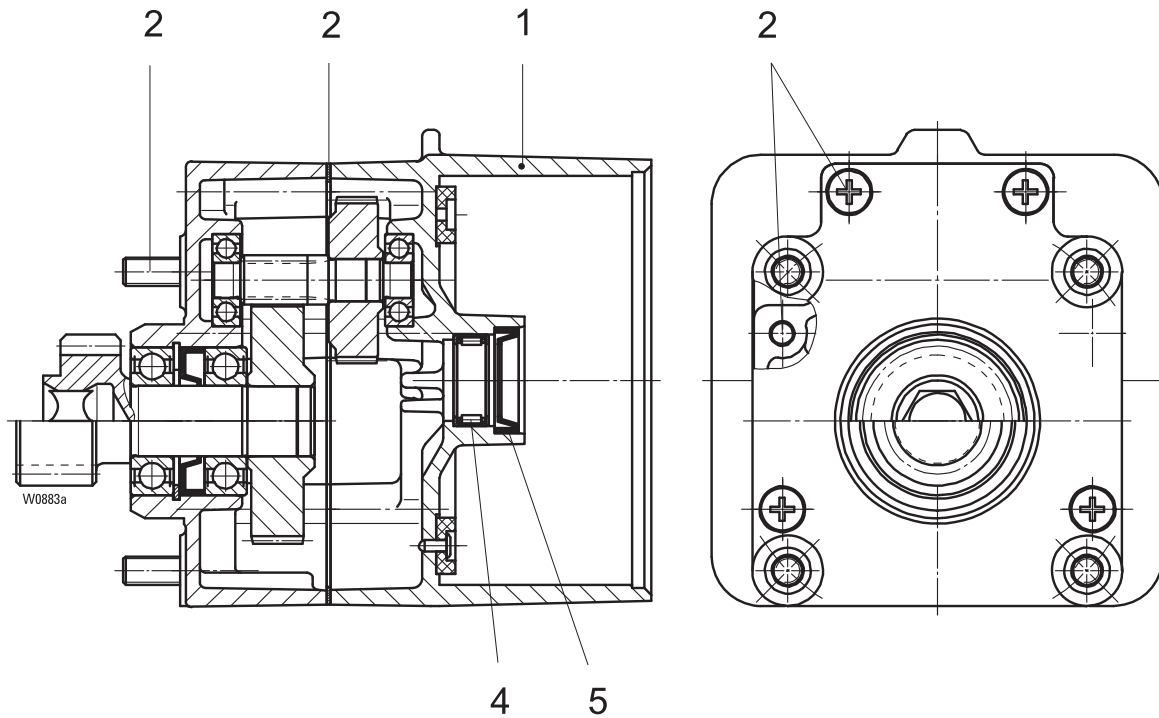

Pos	Teil-Nummer Part-Number	Stück Piece	Beschreibung Description	Benennung Designation	
	51 250 04 29 0	1	SU-A 12 4. 110 (Pos.1-5)	Getriebe komplett Gear complete	
	51 250 05 29 0	1	SU-A 12 4. 108 (Pos.1-5)		
	51 250 06 29 0	1	SU-A 12 4. 106 (Pos.1-5)		
	51 250 07 29 0	1	SU-A 12 4. 104 (Pos.1-5)		
	51 250 22 29 0	1	SU-A 12 4. 222 (Pos.1-5)		
	51 250 23 29 0	1	SU-A 12 4. 220 (Pos.1-5)		
	51 250 24 29 0	1	SU-A 12 4. 218 (Pos.1-5)		
	51 250 25 29 0	1	SU-A 12 4. 216 (Pos.1-5)		
	51 250 26 29 0	1	SU-A 12 4. 214 (Pos.1-5)		
	51 250 27 29 0	1	SU-A 12 4. 212 (Pos.1-5)		
1	51 250 79 37 0	1	SU-A 12 4. 1.. (Pos.4+5)		Getriebegehäuse mit Bremsb. Gear box with brake lining
	51 250 78 37 0	1	SU-A 12 4. 2.. (Pos.4+5)		
2	51 250 01 64 0	1			Getriebe-Dichtung Set Gear seal set
4	1	HK2010 1)		Nadelhülse Needle bush
5	1	20x30x7 2)	Wellendichtring Shaft seal	

1) siehe Pos.11 Seite 22
2) siehe Pos.10 Seite 22

1) see pos.11 page 22
2) see pos.10 page 22



Austausch und Reparaturen nur von geschultem Personal ausführen lassen.

Replacement and repairs may only be carried out by trained personnel.

Die Angaben in der Spalte "Benennung" dienen nur internen Vorgängen.

The information in the column "Designation" is only for internal use.

8/2F12

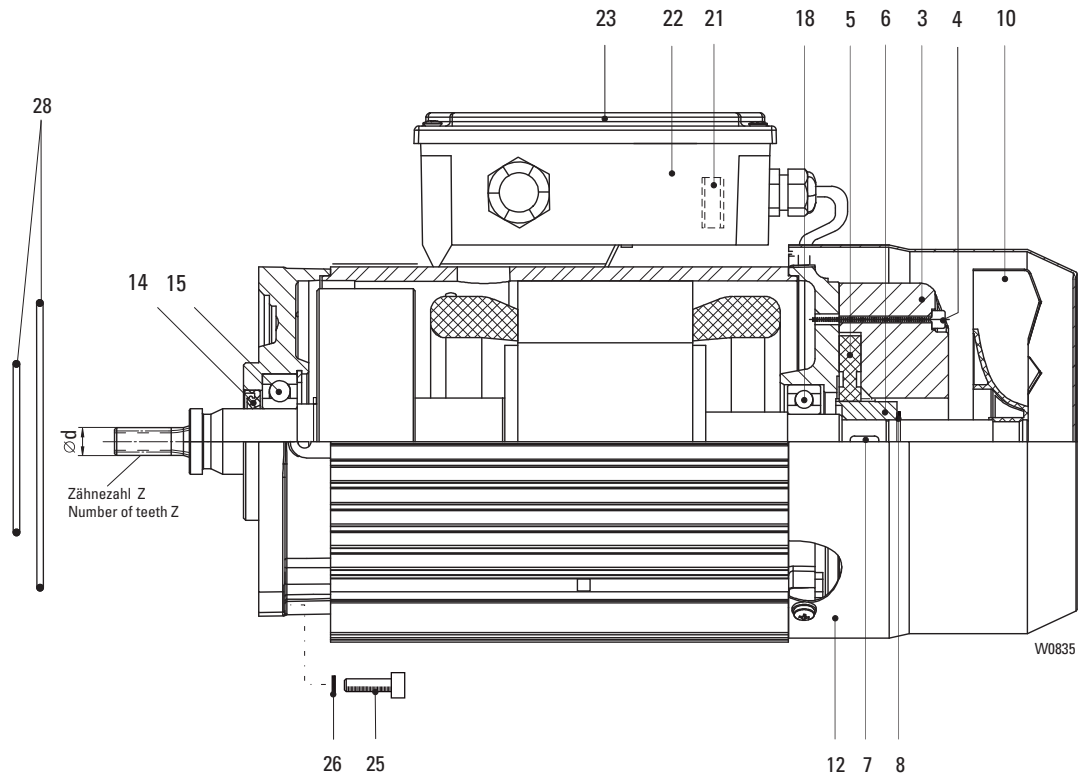

Pos	Teil-Nummer Part-Number	Stück Piece	Beschreibung Description			Z	d	Benennung	Designation
	21 270 87 11 9	1	SF 17 113 123	1)	(Pos.1-23)	6	9,60	Motor kompl.	Motor compl.
		1	SF 14 113 123	1)	(Pos.1-23)				
	21 270 86 11 9	1	SF 17 111 123	1)	(Pos.1-23)	7	10,75		
		1	SF 17 219 123	1)	(Pos.1-23)				
		1	SF 15 226 123	1)	(Pos.1-23)				
		1	SF 14 111 123	1)	(Pos.1-23)				
		1	SF 25 230 123	1)	(Pos.1-23)				
		1	SF 11 226 123	1)	(Pos.1-23)				
		1	SF 11 224 123	1)	(Pos.1-23)				
	21 270 85 11 9	1	SF 17 109 123	1)	(Pos.1-23)	9	12,85		
		1	SF 17 217 123	1)	(Pos.1-23)				
		1	SF 15 224 123	1)	(Pos.1-23)				
		1	SF 14 109 123	1)	(Pos.1-23)				
		1	SF 25 226 123	1)	(Pos.1-23)				
		1	SF 25 228 123	1)	(Pos.1-23)				
		1	SF 11 217 123	1)	(Pos.1-23)				
		1	SF 11 224 123	1)	(Pos.1-23)				
		1	SA-C 57 38 123	1)	(Pos.1-23)				
		1	SA-C 57 42 123	1)	(Pos.1-23)				
		1	SA-C 57 40 123	1)	(Pos.1-23)				
		1	SA-C 67 42 123	1)	(Pos.1-23)				
		1	SA-C 67 44 123	1)	(Pos.1-23)				
1	SA-C 67 46 123	1)	(Pos.1-23)						
	21 270 84 11 9	1	SF 17 107 123	1)	(Pos.1-23)	11	14,95		
		1	SF 17 215 123	1)	(Pos.1-23)				
		1	SF 15 222 123	1)	(Pos.1-23)				
		1	SF 14 107 123	1)	(Pos.1-23)				
		1	SF 11 215 123	1)	(Pos.1-23)				
		1	SF 11 222 123	1)	(Pos.1-23)				



Pos	Teil-Nummer Part-Number	Stück Piece	Beschreibung Description				Benennung Designation		
					Z	d			
	21 270 83 11 9	1	SF 17 213 123	1)	(Pos.1-23)	9	19,20	Motor kompl.	Motor complete
		1	SF 15 220 123	1)	(Pos.1-23)				
		1	SF 25 222 123	1)	(Pos.1-23)				
		1	SF 25 224 123	1)	(Pos.1-23)				
		1	SF 11 213 123	1)	(Pos.1-23)				
		1	SF 11 220 123	1)	(Pos.1-23)				
	21 270 82 11 9	1	SF 17 211 123	1)	(Pos.1-23)	11	22,30		
		1	SF 15 218 123	1)	(Pos.1-23)				
		1	SA-C 57 36 123	1)	(Pos.1-23)				
		1	SA-C 67 40 123	1)	(Pos.1-23)				
	21 270 74 11 9	1	SF 17 209 123	1)	(Pos.1-17)	9	27,85		
	21 270 73 11 9	1	SF 17 207 123	1)	(Pos.1-17)	11	32,35		
3	567 102 0	1	104 - 120V	2)	190 - 460V	50Hz	3)	Bremse	Brake
	567 103 0	1	130 - 150V	2)	480 - 525V	50Hz	3)		
	567 104 0	1	156 - 180V	2)	575 - 720V	50Hz	3)		
4	502 942 0	3	M4x45		ISO 4762			Zyl-Schraube	Socket head cap screw
5	567 100 0	1	Gr.08					Bremsrotor	Brake rotor
6	567 349 0	1						Nabe	Hub
7	537 011 0	1	5x5x16		DIN 6885			Passfeder	Feather key
8	506 093 0	1	15x1		DIN 471			Sicherungsring	Circlip
10	576 051 0	1						Lüfterrad	Fan wheel
12	567 344 0	1						Lüfterhaube	Fan cowling
14	561 012 0	1	20x35x7	4)				Wellendichtring	Shaft seal
15	560 091 0	1	6204-2RS		DIN 625			Rillenkugellager	Grooved ball bearing
18	560 017 0	1	6202-2RS		DIN 625			Rillenkugellager	Grooved ball bearing
21	567 108 0	1	PME400	5)				Gleichrichter	Rectifier
	567 190 0	1	PMB400	6)					
22	570 076 0	1						Klemmenkasten	Terminal box
23	567 347 0	1						Klemmenkastendeckel	Terminal box lid
25	500 231 0	4	M6x20		ISO 4762-8.8			Zyl-Schraube	Socket head cap screw
26	506 838 0	4	S6					Sicherungsscheibe	Lock washer
28	515 020 0	1	130x2		SF 1.			Runddichtring	Round sealing ring
	515 953 0	1	70x2		SF 25; SA-C .7				

1) Bitte Betriebsspannung, Frequenz, Getriebemotortyp und Motortyp angeben.

1) Please state operating voltage, frequency, type of geared motor and type of motor.

2) Spulenspannung

2) Coil voltage

3) Betriebsspannung Motor

3) Operating voltage motor

4) nur austauschbar bei Z 6 - 11, d < 20mm

4) Only replaceable at Z 6 - 11, d < 20mm

5) Nicht für Motorspannungen 190...210V/60Hz

5) Not for supply voltage 190...210V/60Hz

6) Nur für Motorspannungen 190...210V/60Hz

6) Only for supply voltage 190...210V/60Hz

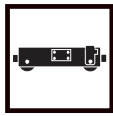

8/2F13

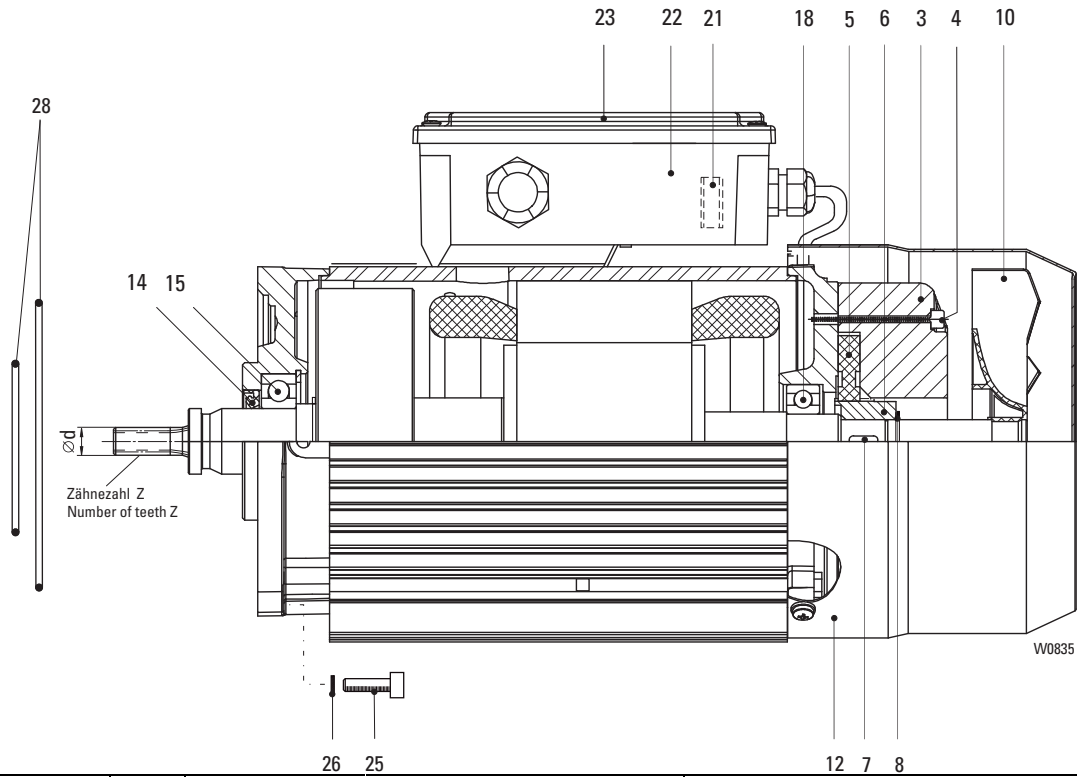

Pos	Teil-Nummer Part-Number	Stück Piece	Beschreibung Description	Benennung Designation
	21 270 81 11 9	1	SF 17 111 133 1) (Pos.1-23)	Motor kompl. Motor compl.
		1	1) (Pos.1-23)	
	21 270 80 11 9	1	SF 11 217 133 1) (Pos.1-23)	Motor kompl. Motor compl.
		1	SF 17 109 133 1) (Pos.1-23)	
		1	SF 17 217 133 1) (Pos.1-23)	
		1	SF 25 226 133 1) (Pos.1-23)	
		1	SF 25 228 133 1) (Pos.1-23)	
		1	SA-C 57 38 133 1) (Pos.1-23)	
		1	SA-C 57 40 133 1) (Pos.1-23)	
		1	SA-C 67 42 133 1) (Pos.1-23)	
		1	SA-C 67 44 133 1) (Pos.1-23)	
		1	SA-C 67 46 133 1) (Pos.1-23)	
	21 270 79 11 9	1	SF 11 215 133 1) (Pos.1-23)	Motor kompl. Motor compl.
		1	SF 17 107 133 1) (Pos.1-23)	
		1	SF 17 215 133 1) (Pos.1-23)	
		1	SF 15 222 133 1) (Pos.1-23)	
	21 270 78 11 9	1	SF 11 213 133 1) (Pos.1-23)	Motor kompl. Motor compl.
		1	SF 11 220 133 1) (Pos.1-23)	
		1	SF 17 213 133 1) (Pos.1-23)	
		1	SF 15 220 133 1) (Pos.1-23)	
		1	SF 25 222 133 1) (Pos.1-23)	
		1	SF 25 224 133 1) (Pos.1-23)	
	21 270 77 11 9	1	SF 11 211 133 1) (Pos.1-23)	Motor kompl. Motor compl.
		1	SF 17 211 133 1) (Pos.1-23)	
		1	SF 15 218 133 1) (Pos.1-23)	
		1	SA-C 57 32 133 1) (Pos.1-23)	
		1	SA-C 57 34 133 1) (Pos.1-23)	
		1	SA-C 57 36 133 1) (Pos.1-23)	
		1	SA-C 67 36 133 1) (Pos.1-23)	
		1	SA-C 67 38 133 1) (Pos.1-23)	
		1	SA-C 67 40 133 1) (Pos.1-23)	



Pos	Teil-Nummer Part-Number	Stück Piece	Beschreibung Description				Z	d	Benennung	Designation
	21 270 76 11 9	1	SF 17 209 133	1)	(Pos.1-23)	9	27,85	Motor kompl.	Motor complete	
		1	SF 15 216 133	1)	(Pos.1-23)					
		1	SF 25 218 133	1)	(Pos.1-23)					
		1	SF 25 220 133	1)	(Pos.1-23)					
	21 270 75 11 9	1	SF 17 207 133	1)	(Pos.1-23)	11	32,35			
		1	SF 15 214 133	1)	(Pos.1-23)					
	21 270 71 11 9	1	SF 35 832 133	1)	(Pos.1-23)	13	36,90			
		1	SF 35 834 133	1)	(Pos.1-23)					
		1	SF 35 836 133	1)	(Pos.1-23)					
		1	SF 25 830 133	1)	(Pos.1-23)					
		1	SF 25 832 133	1)	(Pos.1-23)					
		1	SF 25 834 133	1)	(Pos.1-23)					
3	567 135 0	1	104 - 120V	2)	190 - 460V	50Hz	3)	Bremse	Brake	
	567 188 0	1	130 - 150V	2)	480 - 525V	50Hz	3)			
	567 189 0	1	156 - 180V	2)	575 - 720V	50Hz	3)			
4	502 942 0	3	M4x45		ISO 4762			Zyl-Schraube	Socket head cap screw	
5	567 100 0	1	Gr.08					Bremsrotor	Brake rotor	
6	567 349 0	1						Nabe	Hub	
7	537 011 0	1	5x5x16		DIN 6885			Passfeder	Feather key	
8	506 093 0	1	15x1		DIN 471			Sicherungsring	Circlip	
10	576 051 0	1						Lüfterrad	Fan wheel	
12	567 344 0	1						Lüfterhaube	Fan cowl	
14	561 012 0	1	20x35x7	4)				Wellendichtring	Shaft seal	
15	560 091 0	1	6204-2RS		DIN 625			Rillenkugellager	Grooved ball bearing	
18	560 017 0	1	6202-2RS		DIN 625			Rillenkugellager	Grooved ball bearing	
21	567 108 0	1	PME400	5)				Gleichrichter	Rectifier	
	567 190 0	1	PMB400	6)						
22	570 076 0	1						Klemmenkasten	Terminal box	
23	567 347 0	1						Klemmenkastendeckel	Terminal box cover	
25	500 231 0	4	M6x20		ISO 4762-8.8			Zyl-Schraube	Socket head cap screw	
26	506 838 0	4	S6					Sicherungsscheibe	Lock washer	
28	515 020 0	1	130x2		SF1.			Runddichtring	Round sealing ring	
	515 953 0	1	70x2		SF25; SF35; SA-C.7					

1) Bitte Betriebsspannung, Frequenz, Getriebemotortyp und Motortyp angeben.

1) Please state operating voltage, frequency, type of geared motor and type of motor.

2) Spulenspannung

2) Coil voltage

3) Betriebsspannung Motor

3) Operating voltage motor

4) nur austauschbar bei Z 7 - 11, d < 20mm

4) Only replaceable at Z 7 - 11, d < 20mm

5) Nicht für Motorspannungen 190...210V/60Hz

5) Not for supply voltage 190...210V/60Hz

6) Nur für Motorspannungen 190...210V/60Hz

6) Only for supply voltage 190...210V/60Hz



8/2F31

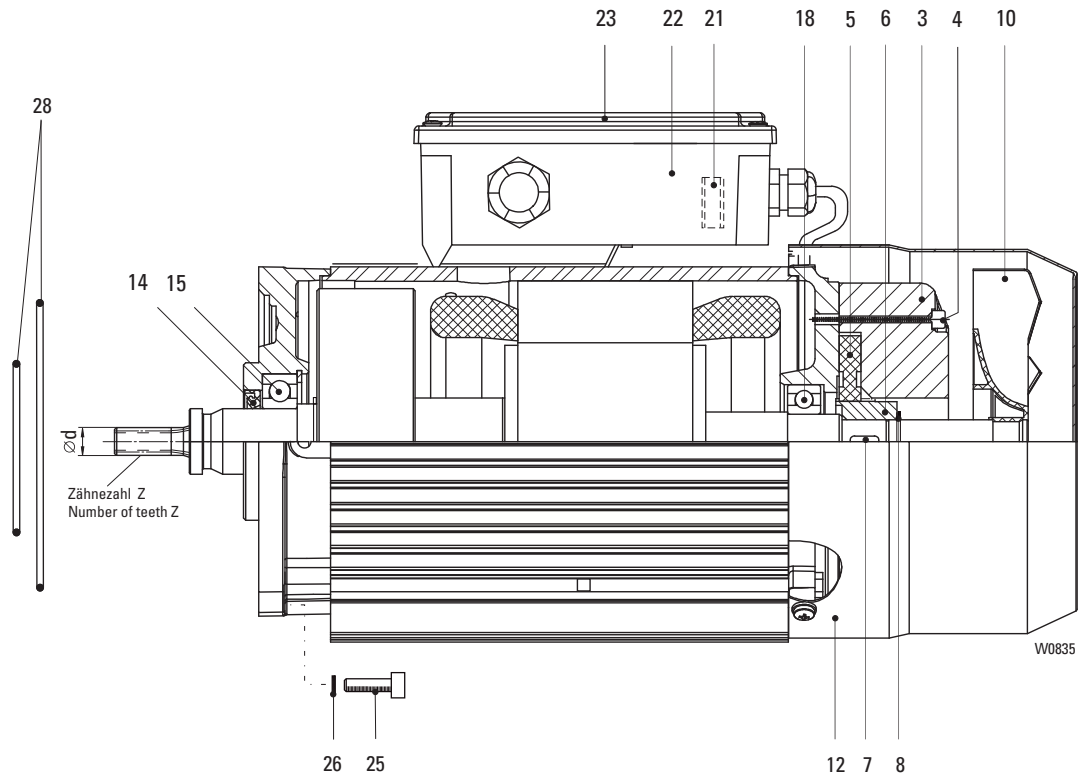

Pos	Teil-Nummer Part-Number	Stück Piece	Beschreibung Description	Benennung Designation
	23 270 77 11 9	1	SF 11 217 313 1) (Pos.1-23)	Motor kompl. Motor compl.
		1	SF 25 226 313 1) (Pos.1-23)	
		1	SF 25 228 313 1) (Pos.1-23)	
		1	SA-C 57 38 313 1) (Pos.1-23)	
		1	SA-C 67 42 313 1) (Pos.1-23)	
		1	SA-C 67 44 313 1) (Pos.1-23)	
	23 270 76 11 9	1	SF 11 213 313 1) (Pos.1-23)	Motor kompl. Motor compl.
		1	SF 17 213 313 1) (Pos.1-23)	
		1	SF 25 222 313 1) (Pos.1-23)	
		1	SF 25 224 313 1) (Pos.1-23)	
		1	SF 35 226 313 1) (Pos.1-23)	
		1	SF 35 228 313 1) (Pos.1-23)	
	23 270 79 11 9	1	SF 25 218 313 1) (Pos.1-23)	Motor kompl. Motor compl.
		1	SF 25 220 313 1) (Pos.1-23)	
	23 270 75 11 9	1	SF 25 216 313 1) (Pos.1-23)	Motor kompl. Motor compl.
		1	SF 35 834 313 1) (Pos.1-23)	
		1	SF 35 832 313 1) (Pos.1-23)	
	23 270 71 11 9	1	SF 11 215 313 1) (Pos.1-23)	Motor kompl. Motor compl.
		1	SF 35 230 313 1) (Pos.1-23)	
	23 270 80 11 9	1	SA-C 57 36 313 1) (Pos.1-23)	Motor kompl. Motor compl.
		1	SA-C 57 34 313 1) (Pos.1-23)	
		1	SA-C 57 32 313 1) (Pos.1-23)	
		1	SA-C 57 30 313 1) (Pos.1-23)	
		1	SA-C 57 28 313 1) (Pos.1-23)	
		1	SA-C 57 26 313 1) (Pos.1-23)	
		1	SA-C 67 40 313 1) (Pos.1-23)	
		1	SA-C 67 38 313 1) (Pos.1-23)	
		1	SA-C 67 36 313 1) (Pos.1-23)	
		1	SA-C 67 34 313 1) (Pos.1-23)	
		1	SA-C 67 32 313 1) (Pos.1-23)	
		1	SA-C 67 30 313 1) (Pos.1-23)	



Pos	Teil-Nummer Part-Number	Stück Piece	Beschreibung Description				Benennung	Designation	
3	567 128 0	1	104 - 120V	2)	190 - 460V	50Hz	3)	Bremse	Brake
	567 129 0	1	130 - 150V	2)	480 - 525V	50Hz	3)		
	567 130 0	1	156 - 180V	2)	575 - 720V	50Hz	3)		
4	500 389 0	3	M6x55		ISO 4762			Zyl-Schraube	Socket head cap screw
5	567 360 0	1						Bremsrotor	Brake rotor
6	567 362 0	1						Nabe	Hub
7	537 008 0	1	6x6x16		DIN 6885			Passfeder	Feather key
8	506 095 0	1	20x1,2		DIN 471			Sicherungsring	Circlip
10	576 052 0	1						Lüfterrad	Fan wheel
12	567 345 0	1						Lüfterhaube	Fan cowling
14	561 053 0	1	30x47x7	4)				Wellendichtring	Shaft seal
15	560 089 0	1	6206-2Z JC3		DIN 625			Rillenkugellager	Grooved ball bearing
18	560 096 0	1	6205-2Z JC3		DIN 625			Rillenkugellager	Grooved ball bearing
21	567 108 0	1	PME400	5)				Gleichrichter	Rectifier
	567 190 0	1	PMB400	6)					
22	570 077 0	1						Klemmenkasten	Terminal box
23	567 348 0	1						Klemmenkastendeckel	Terminal box cover
25	500 148 0	4	M10x25	SF.;	SA-C	ISO 4762-8.8		Zyl-Schraube	Socket head cap screw
	500 236 0	4	M10x30	SF 25		DIN 912-8.8			
26	506 840 0	4	S10					Sicherungsscheibe	Lock washer
28	515 020 0	1	130x2		SF1.			Runddichtring	Round sealing ring
	515 953 0	1	70x2		SF25; SF35; SA-C.7				

1) Bitte Betriebsspannung, Frequenz, Getriebemotortyp und Motortyp angeben.

1) Please state operating voltage, frequency, type of geared motor and type of motor.

2) Spulenspannung

2) Coil voltage

3) Betriebsspannung Motor

3) Operating voltage motor

4) nur austauschbar bei Z 9 - 11, d < 30mm

4) Only replaceable at Z 9 - 11, d < 30mm

5) Nicht für Motorspannungen 190...210V/60Hz

5) Not for supply voltage 190...210V/60Hz

6) Nur für Motorspannungen 190...210V/60Hz

6) Only for supply voltage 190...210V/60Hz



8/2F42

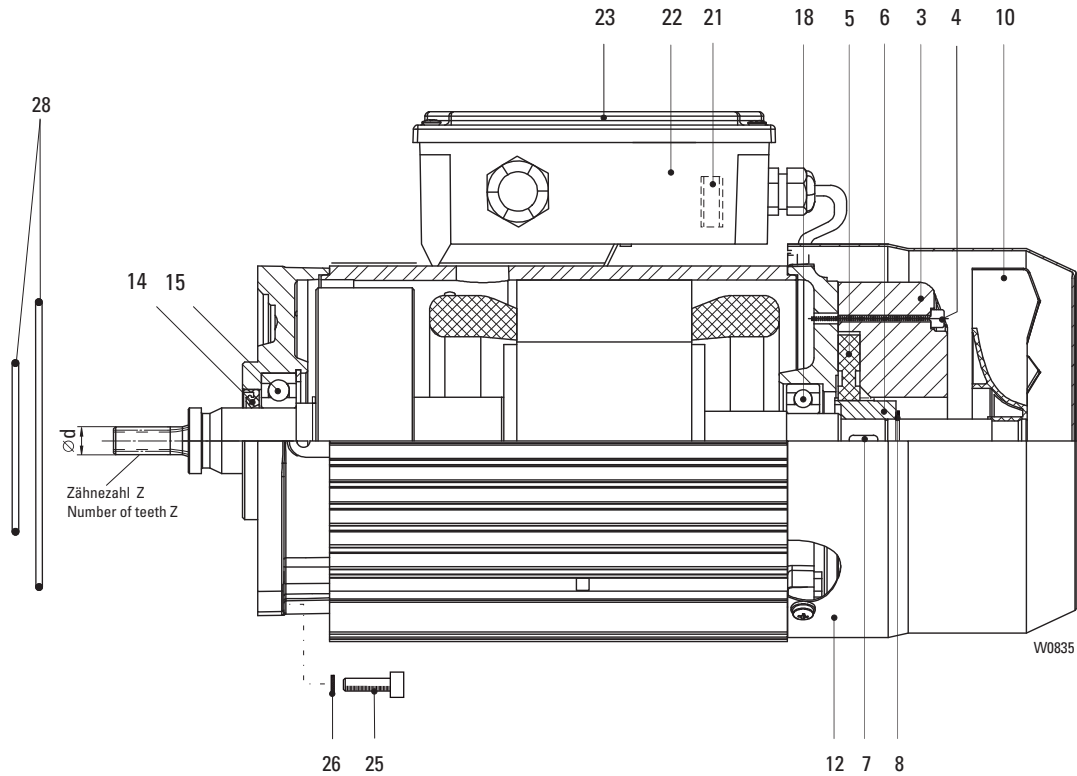

Pos	Teil-Nummer Part-Number	Stück Piece	Beschreibung Description				Benennung Designation	Designation
					Z	d		
	24 270 81 11 9	1	SF 25 216 423	1) (Pos.1-23)	13	36,90	Motor kompl.	Motor compl.
	24 270 82 11 9	1	SF 25 218 423	1) (Pos.1-23)	9	27,85		
		1	SF 25 220 423	1) (Pos.1-23)				
		1	SF 35 224 423	1) (Pos.1-23)				
		1	SF 35 222 423	1) (Pos.1-23)				
	24 270 80 11 9	1	SF 35 230 423	1) (Pos.1-23)	11	14,95		
	24 270 79 11 9	1	SF 25 224 423	1) (Pos.1-23)	9	19,20		
		1	SF 25 222 423	1) (Pos.1-23)				
		1	SF 35 228 423	1) (Pos.1-23)				
		1	SF 35 226 423	1) (Pos.1-23)				
	24 270 65 11 9	1	SA-C 57 32 423	1) (Pos.1-23)	11	22,30		
		1	SA-C 57 30 423	1) (Pos.1-23)				
		1	SA-C 57 28 423	1) (Pos.1-23)				
		1	SA-C 57 26 423	1) (Pos.1-23)				
		1	SA-C 67 38 423	1) (Pos.1-23)				
		1	SA-C 67 36 423	1) (Pos.1-23)				
		1	SA-C 67 34 423	1) (Pos.1-23)				
		1	SA-C 67 32 423	1) (Pos.1-23)				
		1	SA-C 67 30 423	1) (Pos.1-23)				

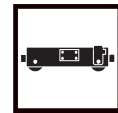

Pos	Teil-Nummer Part-Number	Stück Piece	Beschreibung Description					Benennung	Designation
3	567 131 0	1	104 - 120V	2)	190 - 460V	50Hz	3)	Bremse	Brake
	567 132 0	1	130 - 150V	2)	480 - 525V	50Hz	3)		
	567 133 0	1	156 - 180V	2)	575 - 720V	50Hz	3)		
4	500 389 0	3	M6x55		ISO 4762			Zyl-Schraube	Socket head cap screw
5	567 360 0	1						Bremsrotor	Brake rotor
6	567 362 0	1						Nabe	Hub
7	537 008 0	1	6x6x16		DIN 6885			Passfeder	Feather key
8	506 095 0	1	20x1,2		DIN 471			Sicherungsring	Circlip
10	576 052 0	1						Lüfterrad	Fan wheel
12	567 345 0	1						Lüfterhaube	Fan cowling
14	561 053 0	1	30x47x7	4)				Wellendichtring	Shaft seal
15	560 089 0	1	6206-2Z JC3		DIN 625			Rillenkugellager	Grooved ball bearing
18	560 096 0	1	6205-2ZJ C3		DIN 625			Rillenkugellager	Grooved ball bearing
21	567 108 0	1	PME400	5)				Gleichrichter	Rectifier
	567 190 0	1	PMB400	6)					
22	570 077 0	1						Klemmenkasten	Terminal box
23	567 348 0	1						Klemmenkastendeckel	Terminal box cover
25	500 148 0	4	M10x25	SF 35; SA-C	ISO 4762-8.8			Zyl-Schraube	Socket head cap screw
	500 236 0	4	M10x30	SF 25	DIN 912-8.8				
26	506 840 0	4	S10					Sicherungsscheibe	Lock washer
28	515 953 0	1	70x2		SF25; SF35; SA-C.7			Runddichtring	Round sealing ring

1) Bitte Betriebsspannung, Frequenz, Getriebemotortyp und Motortyp angeben.

1) Please state operating voltage, frequency, type of geared motor and type of motor.

2) Spulenspannung

2) Coil voltage

3) Betriebsspannung Motor

3) Operating voltage motor

4) nur austauschbar bei Z 9 - 11, d < 30mm

4) Only replaceable at Z 9 - 11, d < 30mm

5) Nicht für Motorspannungen 190...210V/60Hz

5) Not for supply voltage 190...210V/60Hz

6) Nur für Motorspannungen 190...210V/60Hz

6) Only for supply voltage 190...210V/60Hz



8/2F52

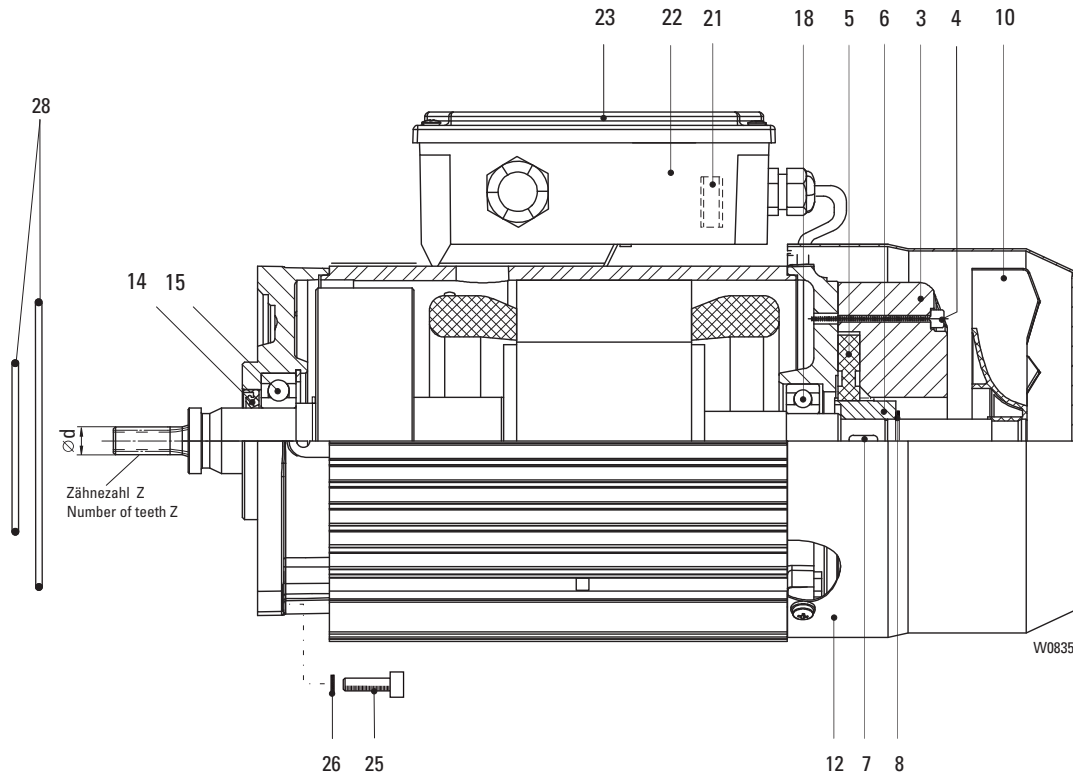

Pos	Teil-Nummer Part-Number	Stück Piece	Beschreibung Description	Benennung Designation
	25 270 85 11 9	1	SA-C 57 26 523 (Pos.1-23)	Motor kompl. Motor compl.
		1	SA-C 57 28 523 (Pos.1-23)	
		1	SA-C 57 30 523 (Pos.1-23)	
		1	SA-C 67 30 523 (Pos.1-23)	
		1	SA-C 67 32 523 (Pos.1-23)	
		1	SA-C 67 34 523 (Pos.1-23)	
		1	SA-C 67 36 523 (Pos.1-23)	
			Z 9	d 27,85

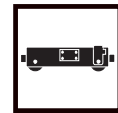

Pos	Teil-Nummer Part-Number	Stück Piece	Beschreibung Description			Benennung	Designation	
3	567 137 0	1	104 - 120V	2)	190 - 460V 50Hz	3)	Bremse	Brake
	567 138 0	1	130 - 150V	2)	480 - 525V 50Hz	3)		
	567 139 0	1	156 - 180V	2)	575 - 720V 50Hz	3)		
4	500 975 0	3	M6x60		ISO 4762		Zyl-Schraube	Socket head cap screw
5	567 361 0	1					Bremsrotor	Brake rotor
6	567 363 0	1					Nabe	Hub
7	537 005 0	1	6x6x20		DIN 6885		Passfeder	Feather key
8	506 095 0	1	20x1,2		DIN 471		Sicherungsring	Circlip
10	576 053 0	1					Lüfterrad	Fan wheel
12	567 346 0	1					Lüfterhaube	Fan cowling
14	561 053 0	1	30x47x7	4)			Wellendichtring	Shaft seal
15	560 089 0	1	6206-2Z JC3		DIN 625		Rillenkugellager	Grooved ball bearing
18	560 096 0	1	6205-2Z JC3		DIN 625		Rillenkugellager	Grooved ball bearing
21	567 108 0	1	PME400	5)			Gleichrichter	Rectifier
	567 190 0	1	PMB400	6)				
22	570 077 0	1					Klemmenkasten	Terminal box
23	567 348 0	1					Klemmenkastendeckel	Terminal box cover
25	500 148 0	4	M10x25		ISO 4762-8.8		Zyl-Schraube	Socket head cap screw
26	506 840 0	4	S10				Sicherungsscheibe	Lock washer
28	515 953 0	1	70x2				Runddichtring	Round sealing ring

1) Bitte Betriebsspannung, Frequenz, Getriebemotortyp und Motortyp angeben.

2) Spulenspannung

3) Betriebsspannung Motor

4) nur austauschbar bei Z 9, d < 30mm

5) Nicht für Motorspannungen 190...210V/60Hz

6) Nur für Motorspannungen 190...210V/60Hz

1) Please state operating voltage, frequency, type of geared motor and type of motor.

2) Coil voltage

3) Operating voltage motor

4) Only replaceable at Z 9, d < 30mm

5) Not for supply voltage 190...210V/60Hz

6) Only for supply voltage 190...210V/60Hz

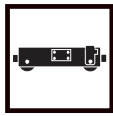

4F18

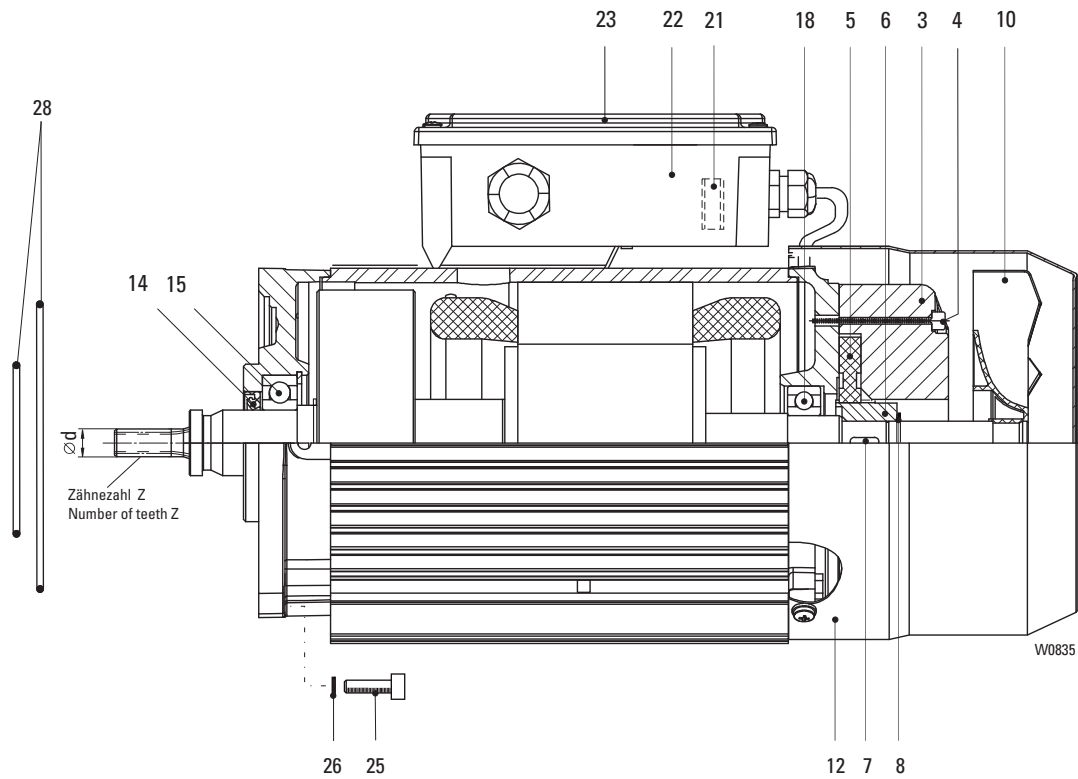

Pos	Teil-Nummer Part-Number	Stück Piece	Beschreibung Description	Benennung Designation
	21 270 62 11 9	1	SF 17 207 184 1) (Pos.1-23)	Motor kompl. Motor compl.
		1	SF 15 214 184 1) (Pos.1-23)	
	21 270 63 11 9	1	SF 17 209 184 1) (Pos.1-23)	Motor kompl. Motor compl.
		1	SF 15 216 184 1) (Pos.1-23)	
		1	SF 25 200 184 1) (Pos.1-23)	
		1	SF 25 218 184 1) (Pos.1-23)	
	21 270 64 11 9	1	SF 11 211 184 1) (Pos.1-23)	Motor kompl. Motor compl.
		1	SF 17 211 184 1) (Pos.1-23)	
		1	SF 15 218 184 1) (Pos.1-23)	
		1	SA-C 57 32 184 1) (Pos.1-23)	
		1	SA-C 57 34 184 1) (Pos.1-23)	
	21 270 65 11 9	1	SF 17 213 184 1) (Pos.1-23)	Motor kompl. Motor compl.
		1	SF 15 220 184 1) (Pos.1-23)	
		1	SF 25 224 184 1) (Pos.1-23)	
		1	SF 25 222 184 1) (Pos.1-23)	
	21 270 66 11 9	1	SF 11 215 184 1) (Pos.1-23)	Motor kompl. Motor compl.
		1	SF 17 215 184 1) (Pos.1-23)	
		1	SF 17 107 184 1) (Pos.1-23)	
		1	SF 15 222 184 1) (Pos.1-23)	
	21 270 67 11 9	1	SF 11 224 184 1) (Pos.1-23)	Motor kompl. Motor compl.
		1	SF 17 217 184 1) (Pos.1-23)	
		1	SF 17 109 184 1) (Pos.1-23)	
		1	SF 15 224 184 1) (Pos.1-23)	
		1	SF 25 228 184 1) (Pos.1-23)	
		1	SF 25 226 184 1) (Pos.1-23)	
		1	SA-C 57 40 184 1) (Pos.1-23)	
		1	SA-C 57 42 184 1) (Pos.1-23)	
		1	SA-C 67 40 184 1) (Pos.1-23)	
		1	SA-C 67 42 184 1) (Pos.1-23)	

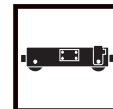

Pos	Teil-Nummer Part-Number	Stück Piece	Beschreibung Description					Benennung Designation	Designation	
						Z	d			
	21 270 68 11 9	1	SF 17 219 184	1)	(Pos.1-23)		7	9,60	Motor kompl. Motor compl.	
		1	SF 17 111 184	1)	(Pos.1-23)					
		1	SF 15 226 184	1)	(Pos.1-23)					
		1	SF 25 230 184	1)	(Pos.1-23)					
	21 270 69 11 9	1	SF 17 113 184	1)	(Pos.1-23)		6	9,60		
	21 270 61 11 9	1	SF 25 834 184	1)	(Pos.1-23)		13	36,90		
		1	SF 25 832 184	1)	(Pos.1-23)					
		1	SF 35 836 184	1)	(Pos.1-23)					
		1	SF 35 834 184	1)	(Pos.1-23)					
		1	SF 35 832 184	1)	(Pos.1-23)					
3	567 135 0 567 134 0	1 1	104 - 120V 180 - 207V	2) 2)	190 - 240V 380 - 460V	50Hz 50Hz	3) 3)			Bremse Brake
4	502 942 0	3	M4x45		ISO 4762					Zyl-Schraube Socket head cap screw
5	567 100 0	1	Gr.08							Bremsrotor Brake rotor
6	567 349 0	1							Nabe Hub	
7	537 011 0	1	5x5x16		DIN 6885				Passfeder Feather key	
8	506 093 0	1	15x1		DIN 471				Sicherungsring Circlip	
10	576 051 0	1							Lüfterrad Fan wheel	
12	567 344 0	1							Lüfterhaube Fan cowling	
14	561 012 0	1	20x35x7	4)					Wellendichtring Shaft seal	
15	560 091 0	1	6204-2RS		DIN 625				Rillenkugellager Grooved ball bearing	
18	560 017 0	1	6202-2RS		DIN 625				Rillenkugellager Grooved ball bearing	
21	567 108 0	1	PME400	5)					Gleichrichter Rectifier	
	567 367 0	1	PME500	6)						
22	570 077 0	1							Klemmenkasten Terminal box	
23	567 347 0	1							Klemmenkastendeckel Terminal box cover	
25	500 231 0	4	M6x20		ISO 4762-8.8				Zyl-Schraube Socket head cap screw	
26	506 838 0	4	S6						Sicherungsscheibe Lock washer	
28	515 020 0	1	130x2		SF1.				Runddichtring Round sealing ring	
	515 953 0	1	70x2		SF25; SF35;SA-C					

1) Bitte Betriebsspannung, Frequenz, Getriebemotortyp und Motortyp angeben.

1) Please state operating voltage, frequency, type of geared motor and type of motor.

2) Spulenspannung

2) Coil voltage

3) Betriebsspannung Motor

3) Operating voltage motor

4) nur austauschbar bei Z 6 - 11, d < 20mm

4) Only replaceable at Z 6 - 11, d < 20mm

5) Nicht für Motorspannungen 380...460V/50Hz, 440...480V/60Hz

5) Not for supply voltage 380...460V/50Hz, 440...480V/60Hz

6) Nur für Motorspannungen 1380...460V/50Hz, 440...480V/60Hz

6) Only for supply voltage 380...460V/50Hz, 440...480V/60Hz

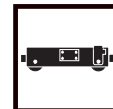

Pos	Teil-Nummer Part-Number	Stück Piece	Beschreibung Description			Benennung	Designation	
3	567 131 0	1	104 - 120V	2)	190 - 240V 50Hz	3)	Bremse	Brake
	567 136 0	1	180 - 207V	2)	380 - 460V 50Hz	3)		
4	500 389 0	3	M6x55		ISO 4762		Zyl-Schraube	Socket head cap screw
5	567 360 0	1					Bremsrotor	Brake rotor
6	567 362 0	1					Nabe	Hub
7	537 008 0	1	6x6x16		DIN 6885		Passfeder	Feather key
8	506 095 0	1	20x1,2		DIN 471		Sicherungsring	Circlip
10	576 052 0	1					Lüfterrad	Fan wheel
12	567 345 0	1					Lüfterhaube	Fan cowling
14	561 053 0	1	30x47x7	4)			Wellendichtring	Shaft seal
15	560 089 0	1	6206-2Z JC3		DIN 625		Rillenkugellager	Grooved ball bearing
18	560 096 0	1	6205-2Z JC3		DIN 625		Rillenkugellager	Grooved ball bearing
21	567 108 0	1	PME400	5)			Gleichrichter	Rectifier
	567 367 0	1	PME500	6)				
22	570 077 0	1					Klemmenkasten	Terminal box
23	567 348 0	1					Klemmenkastendeckel	Terminal box cover
25	500 148 0	4	M10x25	SF1.	ISO 4762-8.8		Zyl-Schraube	Socket head cap screw
	500 236 0	4	M10x30	SF25; SF35	DIN 912-8.8			
26	506 840 0	4	S10				Sicherungsscheibe	Lock washer
28	515 020 0	1	130x2		SF1.		Runddichtring	Round sealing ring
	515 953 0	1	70x2		SF25; SF35			

1) Bitte Betriebsspannung, Frequenz, Getriebemotortyp und Motortyp angeben.

2) Spulenspannung

3) Betriebsspannung Motor

4) nur austauschbar bei Z 9 - 11, d < 30mm

5) Nicht für Motorspannungen 380...460V/50Hz, 440...480V/60Hz

6) Nur für Motorspannungen 1380...460V/50Hz, 440...480V/60Hz

1) Please state operating voltage, frequency, type of geared motor and type of motor.

2) Coil voltage

3) Operating voltage motor

4) Only replaceable at Z 9 - 11, d < 30mm

5) Not for supply voltage 380...460V/50Hz, 440...480V/60Hz

6) Only for supply voltage 380...460V/50Hz, 440...480V/60Hz



4F48

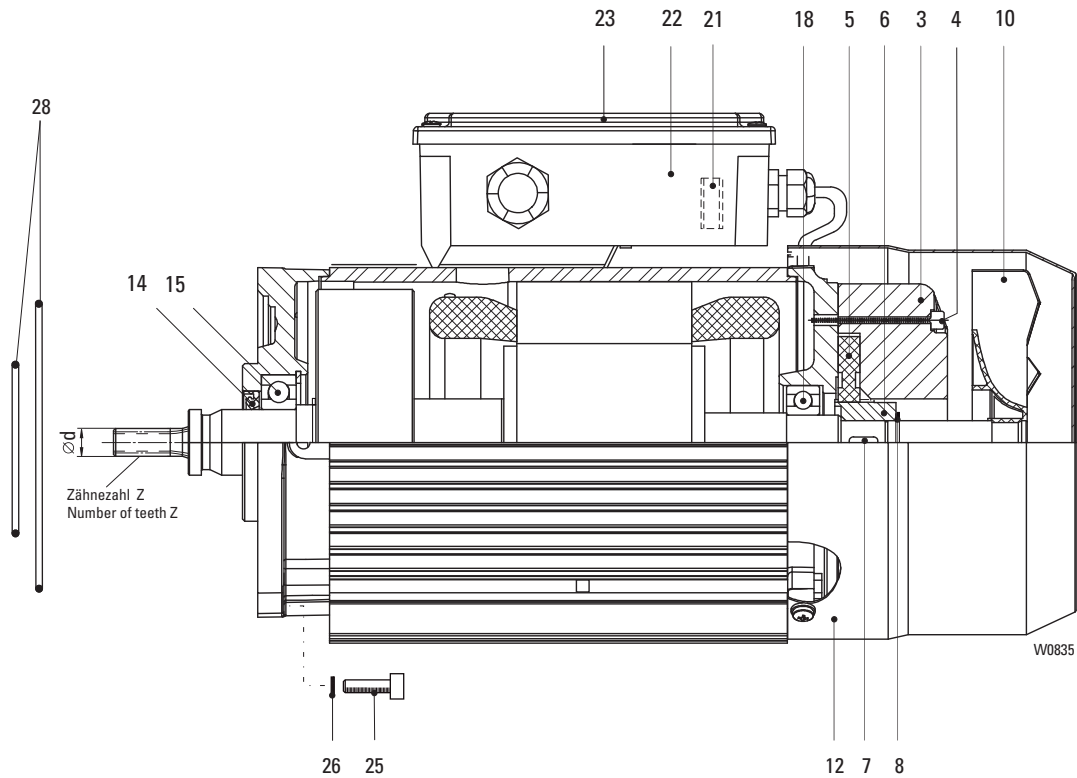

Pos	Teil-Nummer Part-Number	Stück Piece	Beschreibung Description				Benennung Designation	Designation
					Z	d		
	24 270 71 11 9	1	SF 35 230 484	1) (Pos.1-23)	11	14,95	Motor kompl.	Motor compl.
	24 270 70 11 9	1	SF 35 228 484	1) (Pos.1-23)	9	19,20		
		1	SF 35 226 484	1) (Pos.1-23)				
	24 270 69 11 9	1	SF 25 216 484	1) (Pos.1-23)	9	27,85		
		1	SF 25 218 484	1) (Pos.1-23)				
		1	SF 25 220 484	1) (Pos.1-23)				
		1	SF 35 224 484	1) (Pos.1-23)				
		1	SF 35 222 484	1) (Pos.1-23)				

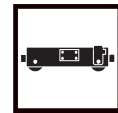

Pos	Teil-Nummer Part-Number	Stück Piece	Beschreibung Description			Benennung	Designation	
3	567 350 0	1	104 - 120V	2)	190 - 240V 50Hz	3)	Bremse	Brake
	567 351 0	1	130 - 150V	2)	380 - 460V 50Hz	3)		
4	500 389 0	3	M6x55		ISO 4762		Zyl-Schraube	Socket head cap screw
5	567 360 0	1					Bremsrotor	Brake rotor
6	567 362 0	1					Nabe	Hub
7	537 008 0	1	6x6x16		DIN 6885		Passfeder	Feather key
8	506 095 0	1	20x1,2		DIN 471		Sicherungsring	Circlip
10	576 052 0	1					Lüfterrad	Fan wheel
12	567 345 0	1					Lüfterhaube	Fan cowling
14	561 053 0	1	30x47x7	4)			Wellendichtring	Shaft seal
15	560 089 0	1	6206-2Z JC3		DIN 625		Rillenkugellager	Grooved ball bearing
18	560 096 0	1	6205-2Z JC3		DIN 625		Rillenkugellager	Grooved ball bearing
21	567 108 0	1	PME400	5)			Gleichrichter	Rectifier
	567 367 0	1	PME500	6)				
22	570 077 0	1					Klemmenkasten	Terminal box
23	567 348 0	1					Klemmenkastendeckel	Terminal box cover
25	500 148 0	4	M10x25		ISO 4762-8.8		Zyl-Schraube	Socket head cap screw
26	506 840 0	4	S10				Sicherungsscheibe	Lock washer
28	515 953 0	1	70x2				Runddichtring	Round sealing ring

1) Bitte Betriebsspannung, Frequenz, Getriebemotortyp und Motortyp angeben.

2) Spulenspannung

3) Betriebsspannung Motor

4) nur austauschbar bei Z 9 - 11, d < 30mm

5) Nicht für Motorspannungen 380...460V/50Hz, 440...480V/60Hz

6) Nur für Motorspannungen 1380...460V/50Hz, 440...480V/60Hz

1) Please state operating voltage, frequency, type of geared motor and type of motor.

2) Coil voltage

3) Operating voltage motor

4) Only replaceable at Z 9 - 11, d < 30mm

5) Not for supply voltage 380...460V/50Hz, 440...480V/60Hz

6) Only for supply voltage 380...460V/50Hz, 440...480V/60Hz



Getriebe / gear

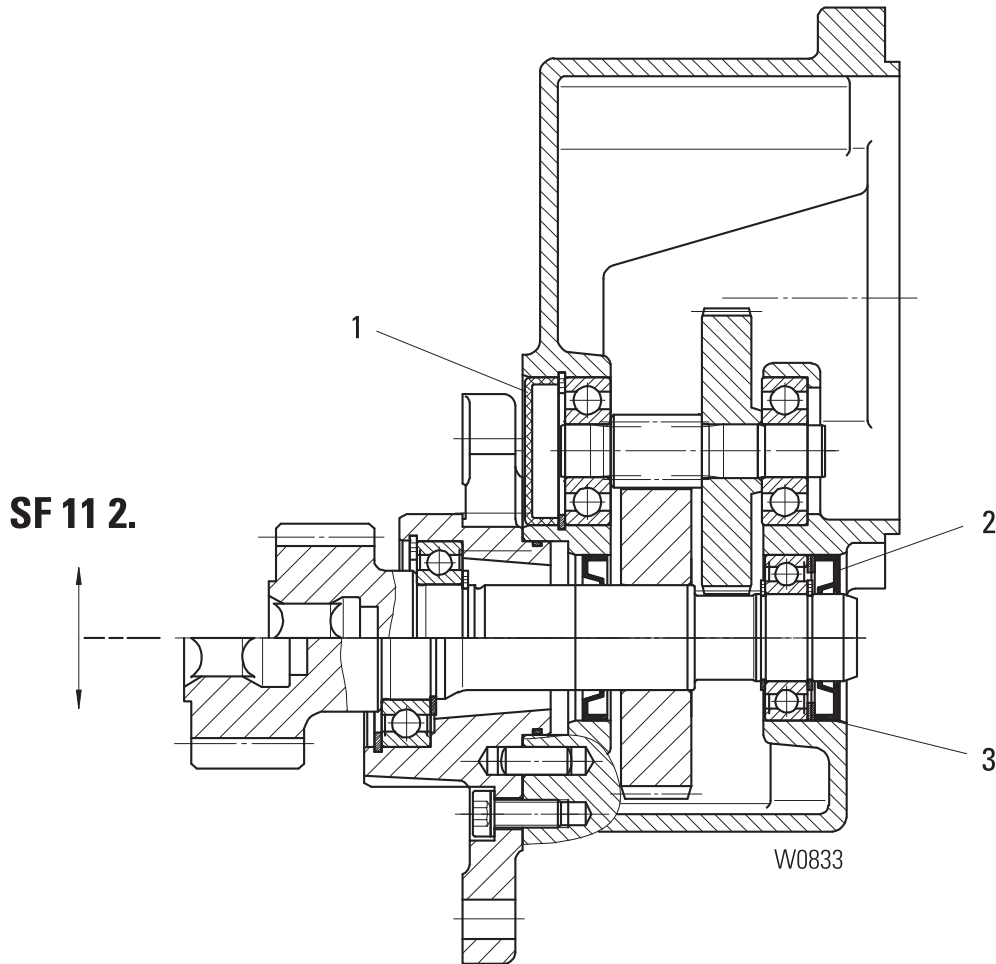

Pos	Teil-Nummer Part-Number	Stück Piece	Beschreibung Description	Benennung	Designation
	21 270 24 30 0	1	SF11 226	Getriebe	Gear
	21 270 25 30 0	1	SF11 224		
	21 270 26 30 0	1	SF11 222		
	21 270 27 30 0	1	SF11 220		
	21 270 28 30 0	1	SF11 217		
	21 270 29 30 0	1	SF11 215		
	21 270 30 30 0	1	SF11 213		
	21 270 31 30 0	1	SF11 211		
1	518 036 0	1	42x9,5		
2	561 120 0	1	25x47x7	Wellendichtring	Shaft seal
3	507 876 0	1	37x47x1	Passscheibe	Adjusting washer

1) Getriebe bis auf gekennzeichnete Teile nur komplett lieferbar.
Ohne Getriebeöl: Erforderliche Menge siehe Betriebsanleitung

1) Gear only available as complete unit except the signed parts
Without gear oil: amount required see operating instruction

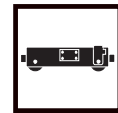

Getriebe / gear

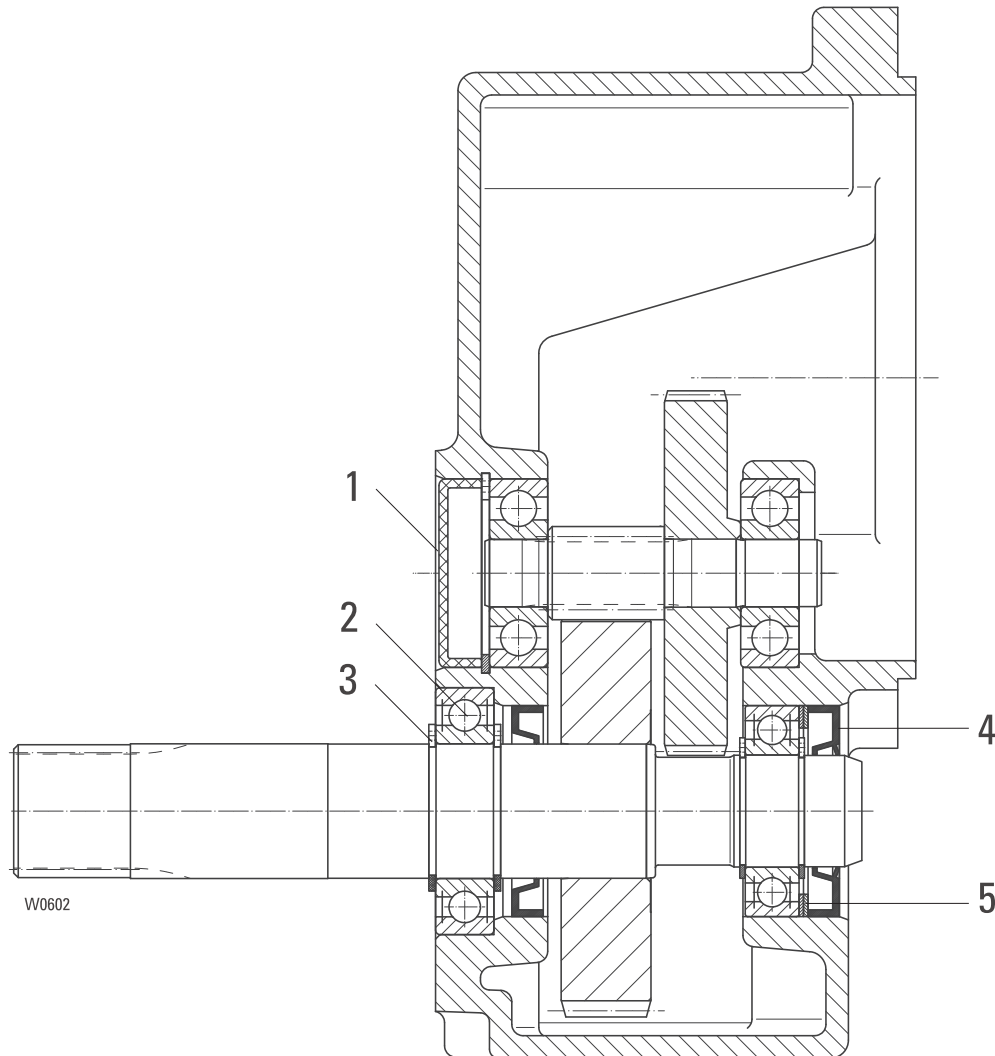

Pos	Teil-Nummer Part-Number	Stück Piece	Beschreibung Description	Benennung	Designation
	21 270 11 30 0	1	SF15 226	Getriebe	Gear
	21 270 12 30 0	1	SF15 224		
	21 270 13 30 0	1	SF15 222		
	21 270 14 30 0	1	SF15 220		
	21 270 15 30 0	1	SF15 218		
	21 270 16 30 0	1	SF15 216		
	21 270 17 30 0	1	SF15 214		
1	518 036 0	1			
2	560 952 0	1	6006-2RS	Rillenkugellager	Grooved ball bearing
3	506 098 0	2	30x1,5	Sicherungsring	Locking ring
4	561 120 0	1	25x47x7	Wellendichtring	Shaft seal
5	507 876 0	2	37x47x1	Passscheibe	Adjusting washer

1) Getriebe bis auf gekennzeichnete Teile nur komplett lieferbar.
Ohne Getriebeöl: Erforderliche Menge siehe Betriebsanleitung

1) Gear only available as complete unit except the signed parts
Without gear oil: amount required see operating instruction

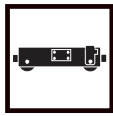

Zwischengetriebe / intermediate gear

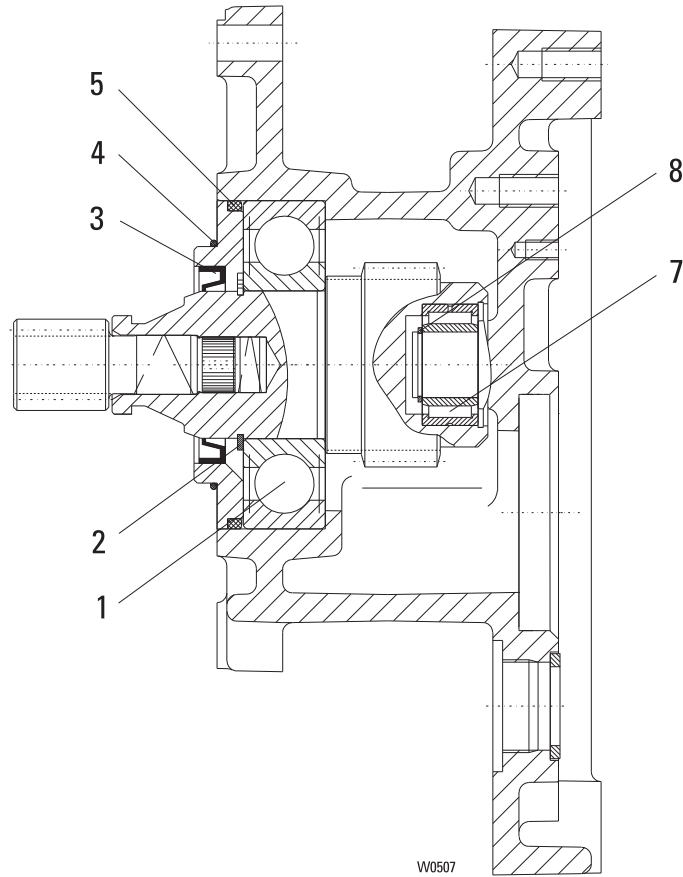

Pos	Teil-Nummer Part-Number	Stück Piece	Beschreibung Description	Benennung	Designation
	24 270 39 30 0	1	SF 25 832	Zwischengetriebe	Intermediate gear
		1	SF 25 834		
	24 270 37 30 0	1	SF 25 830		
1	560 829 0	1	6309-27	Rillenkugellager	Grooved ball bearing
2	506 101 0	1	45x1,75	Sicherungsring	Locking ring
3	561 026 0	1	45x60x8 NB	Wellendichtring	Shaft seal
4	515 953 0	1	70x2	Runddichtring	Round sealing ring
5	515 970 0	1	90x4	Runddichtring	Round sealing ring
7	560 995 0	1	NA 4904	Nadellager	needle roller bearing
8	507 122 0	1	SW 20	Sprengring	Circlip

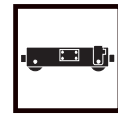

Getriebe / gear

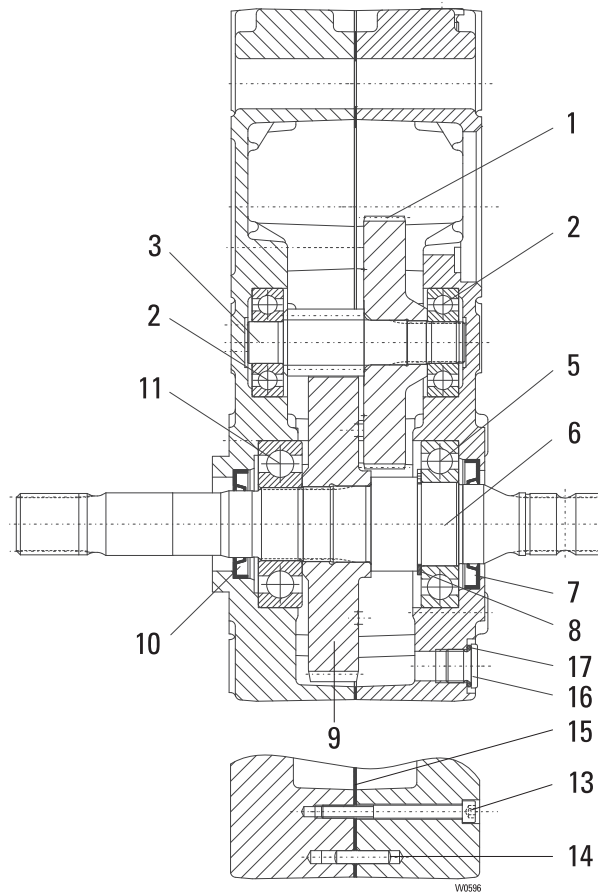

Pos	Teil-Nummer Part-Number	Stück Piece	Beschreibung Description	Benennung	Designation
	22 270 00 30 0	1	SF 25 228, SF 25 834	Getriebe	Gear
	22 270 01 30 0	1	SF 25 226, SF 25 832		
	22 270 02 30 0	1	SF 25 224, SF 25 830		
	22 270 03 30 0	1	SF 25 222		
	22 270 04 30 0	1	SF 25 220		
	22 270 05 30 0	1	SF 25 218		
	22 270 06 30 0	1	SF 25 216		
	22 270 16 30 0	1	SF 25 230		
1	22 273 05 11 0	1	SF 25 228, SF 25 226 SF 25 834, SF 25 832	Zahnrad	Toothed wheel
	22 273 04 11 0	1	SF 25 224, SF 25 222 SF 25 830		
	22 273 03 11 0	1	SF 25 220, SF 25 218		
	22 273 02 11 0	1	SF 25 216		
	22 273 08 11 0	1	SF 25 230		
2	560 053 0	2	6304	Rillenkugellager	Grooved ball bearing
3	23 273 00 19 0	1	SF 25 228, SF 25 224 SF 25 220, SF 25 216, SF 25 230	Ritzelwelle	Pinion shaft
		1	SF 25 834, SF 25 830		
	23 273 01 19 0	1	SF 25 226, SF 25 222 SF 25 218 SF 25 832		
5	560 986 0	1	6208-C3	Rillenkugellager	Grooved ball bearing
6	22 273 04 23 0	1		Abtriebswelle	Drive shaft
7	561 125 0	1	38x62x7	Wellendichtring	Shaft seal
8	506 082 0	1	S40x50x2,5	Stützscheibe	Supporting washer
9	22 273 07 11 0	1	SF 25 228, SF 25 224 SF 25 220, SF 25 216, SF 25 230	Zahnrad	Toothed wheel
		1	SF 25 832, SF 25 830		
	22 273 06 11 0	1	SF 25 226, SF 25 222 SF 25 218 SF 25 832		
10	561 992 0	1	32x52x7	Wellendichtring	Shaft seal
11	560 061 0	1	6307	Rillenkugellager	Grooved ball bearing
13	500 804 0	8	M6x65	Zyl.-Schraube	Socked head cap screw
14	504 029 0	4	6m6x24	Zyl.-Stift	Pin
15	22 273 00 95 0	1		Dichtung	Seal
16	503 954 0	2		Verschlussschraube	Locking bolt
17	515 004 0	2	C16X20	Dichtring	Washer

Ohne Getriebeöl: Erforderliche Menge siehe Betriebsanleitung

Without gear oil: amount required see operating instruction



Zwischengetriebe / intermediate gear

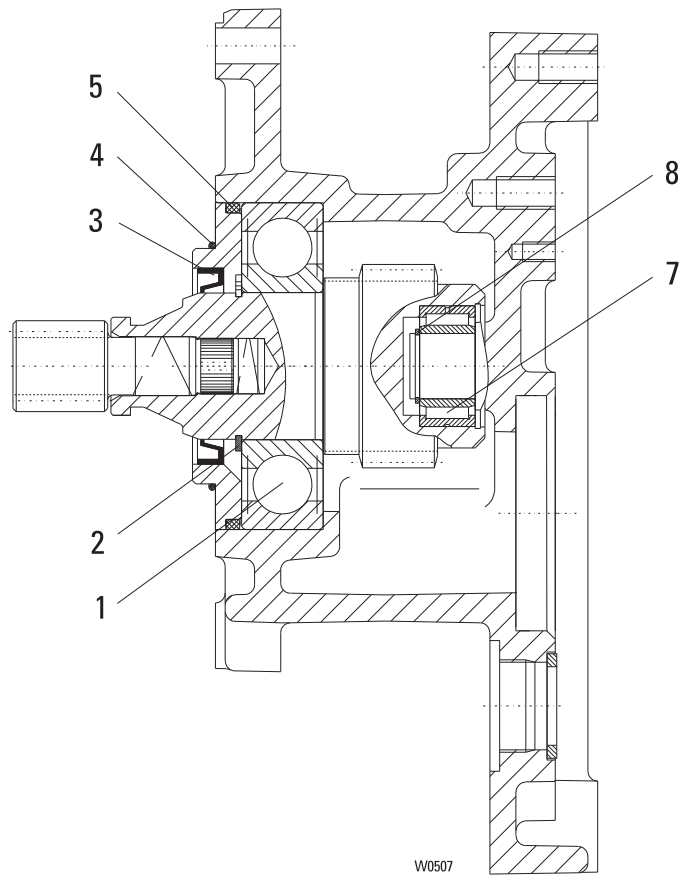

W0507

Pos	Teil-Nummer Part-Number	Stück Piece	Beschreibung Description	Benennung	Designation
	24 270 40 30 0	1	SF 35 836	Zwischengetriebe	Intermediate gear
	24 270 37 30 0	1	SF 35 834		
		1	SF 35 832		
1	560 829 0	1	6309-27	Rillenkugellager	Grooved ball bearing
2	506 101 0	1	45x1,75	Sicherungsring	Locking ring
3	561 026 0	1	45x60x8 NB	Wellendichtring	Shaft seal
4	515 953 0	1	70x2	Runddichtring	Round sealing ring
5	515 970 0	1	90x4	Runddichtring	Round sealing ring
7	560 995 0	1	NA 4904	Nadellager	needle roller bearing
8	507 122 0	1	SW 20	Sprengring	Circlip

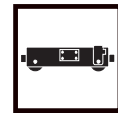

Getriebe / gear

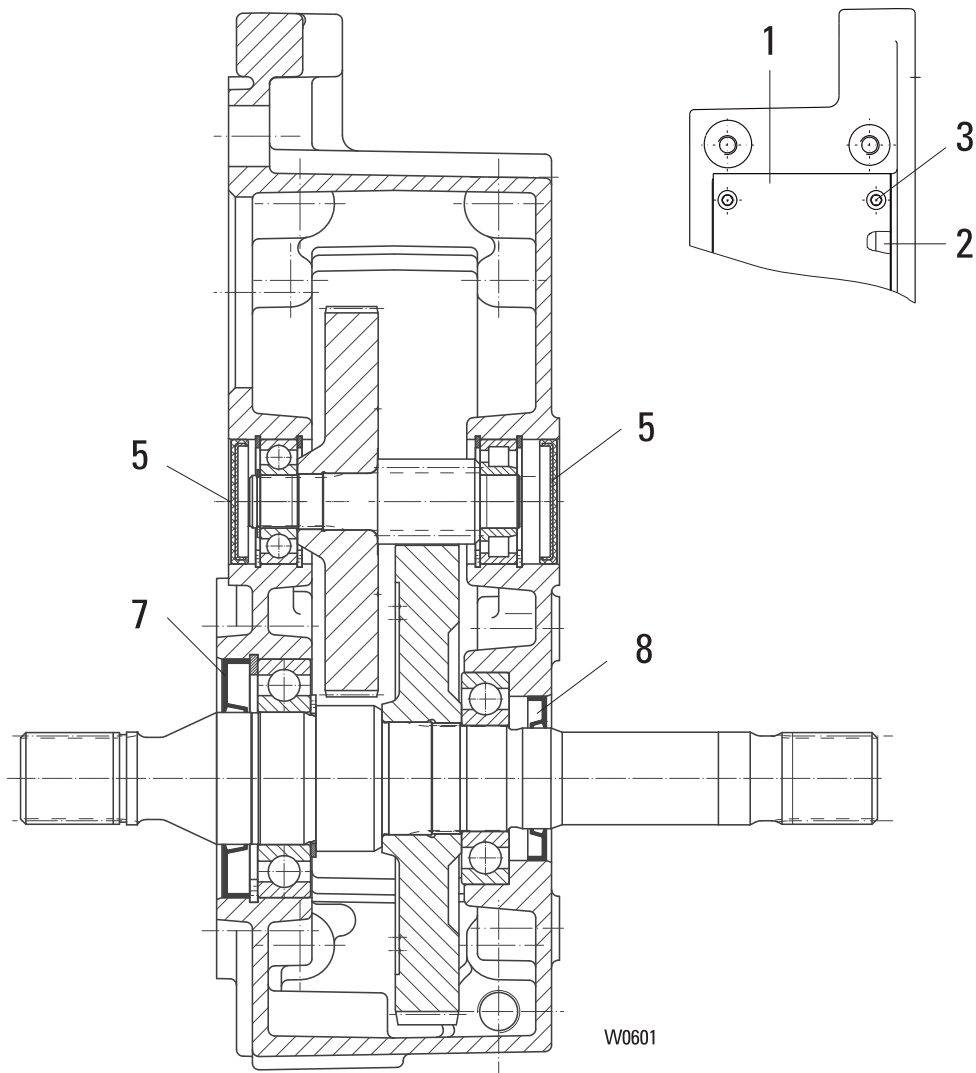

Pos	Teil-Nummer Part-Number	Stück Piece	Beschreibung Description	Benennung	Designation		
	23 270 10 30 0	1	SF 35 230	Getriebe	Gear		
		1	SF 35 836				
	23 270 11 30 0	1	SF 35 228				
		1	SF 35 834				
	23 270 12 30 0	1	SF 35 226				
		1	SF 35 832				
	23 270 13 30 0	1	SF 35 224				
	23 270 14 30 0	1	SF 35 222				
	23 270 15 30 0	1	SF 35 220				
1	23 273 00 96 0	1				Deckel	Cover
2	23 273 00 95 0	1				Dichtung	Seal
3	500 810 0	8	M6x16 DIN 6912-8.8	Zyl-Schraube	Socket head cap screw		
5	518 041 0	1	47x6,5	Verschlusskappe	End cap		
7	561 126 0	1	AS50x90x10	Wellendichtring	Shaft seal		
8	561 125 0	1	AS38x62x7	Wellendichtring	Shaft seal		

1) Getriebe bis auf gekennzeichnete Teile nur komplett lieferbar.
Ohne Getriebeöl: Erforderliche Menge siehe Betriebsanleitung

1) Gear only available as complete unit except the signed parts
Without gear oil: amount required see operating instruction.



Originalteile
Original parts
SA-C 57

STAHL
CraneSystems

Getriebe / gear

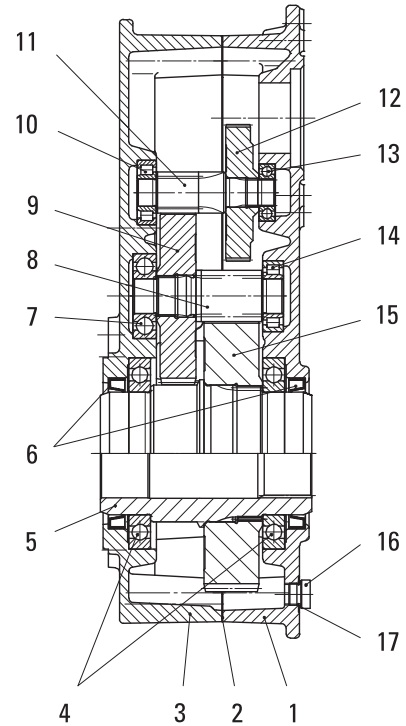
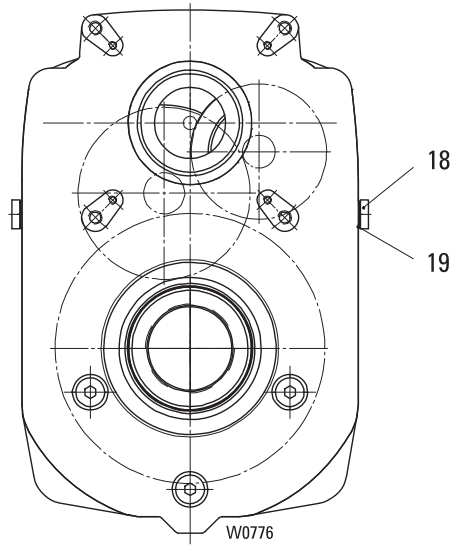
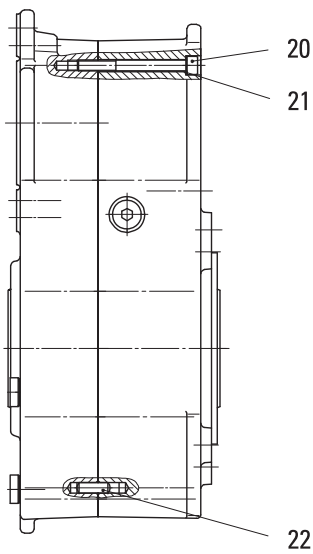

Pos	Teil-Nummer Part-Number	Stück Piece	Beschreibung Description	Benennung Designation	
	15 270 11 30 0	1	SA-. 57 42 (Pos.1-22)	Getriebe Gear	
	15 270 12 30 0	1	SA-. 57 40 (Pos.1-22)		
	15 270 13 30 0	1	SA-. 57 38 (Pos.1-22)		
	15 270 14 30 0	1	SA-. 57 36 (Pos.1-22)		
	15 270 15 30 0	1	SA-. 57 34 (Pos.1-22)		
	15 270 16 30 0	1	SA-. 57 32 (Pos.1-22)		
	15 270 17 30 0	1	SA-. 57 30 (Pos.1-22)		
	15 270 18 30 0	1	SA-. 57 28 (Pos.1-22)		
	15 270 19 30 0	1	SA-. 57 26 (Pos.1-22)		
	15 270 20 30 0	1	SA-. 57 24 (Pos.1-22)		
	15 270 21 30 0	1	SA-. 57 22 (Pos.1-22)		
1	15 277 04 01 0	1			Getriebegehäuse Gear box
2	33 255 00 95 0	1			Dichtung Seal
3	15 277 02 02 0	1		Getriebedeckel Gear cap	
4	560 856 0	2	16018-C3 DIN 625	Rillenkugellager Grooved ball bearing	
5	15 277 01 23 0	1		Abtriebswelle Drive shaft	
6	561 806 0	2	A9x110x12	Wellendichtring Shaft seal	
7	560 020 0	1	6305 DIN 625	Rillenkugellager Grooved ball bearing	
8	15 277 13 19 0	1	SA-. 57 42	Ritzelwelle Pinion	
		1	SA-. 57 36		
		1	SA-. 57 38		
		1	SA-. 57 32		
		1	SA-. 57 24		
	15 277 14 19 0	1	SA-. 57 40		
		1	SA-. 57 34		
		1	SA-. 58 30		
		1	SA-. 57 28		
		1	SA-. 57 26		
		1	SA-. 57 22		
9	15 277 13 11 0	1	SA-. 57 42	Zahnrad Toothed wheel	
		1	SA-. 57 40		
		1	SA-. 57 36		
		1	SA-. 57 34		
	15 277 14 11 0	1	SA-. 57 38		
		1	SA-. 57 32		
		1	SA-. 57 30		
	15 277 15 11 0	1	SA-. 57 28		
		1	SA-. 57 26		
		1	SA-. 57 24		
		1	SA-. 57 22		

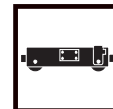

Pos	Teil-Nummer Part-Number	Stück Piece	Beschreibung Description	Benennung Designation	Designation	
10	560 812 0	1	NJ 204 EC	DIN 5412	Zyl-Rollenlager	Roller bearing
11	15 277 10 19 0	1	SA-. 57 42	z=12	Ritzelwelle	Pinion
		1	SA-. 57 40			
		1	SA-. 57 36			
		1	SA-. 57 34			
	15 277 11 19 0	1	SA-. 57 38	z=17		
		1	SA-. 57 32			
		1	SA-. 57 30			
	15 277 12 19 0	1	SA-. 57 28	z=24		
		1	SA-. 57 26			
		1	SA-. 57 24			
		1	SA-. 57 22			
12	15 277 10 11 0	1	SA-. 57 42	z=91	Zahnrad	Toothed wheel
		1	SA-. 57 40			
		1	SA-. 57 38			
	15 277 11 11 0	1	SA-. 57 36	z=56		
		1	SA-. 57 34			
		1	SA-. 57 32			
		1	SA-. 57 30			
		1	SA-. 57 28			
		1	SA-. 57 26			
	15 277 12 11 0	1	SA-. 57 24	z=35		
		1	SA-. 57 22			
13	560 044 0	1	6004-2RS	DIN 625	Rillenkugellager	Grooved ball bearing
14	560 131 0	1	NJ205 E	DIN 5412	Zyl-Rollenlager	Roller bearing
15	15 277 16 11 0	1	SA-. 57 42	z=79	Zahnrad	Toothed wheel
		1	SA-. 57 38			
		1	SA-. 57 36			
		1	SA-. 57 32			
		1	SA-. 57 28			
		1	SA-. 57 24			
	15 277 17 11 0	1	SA-. 57 40	z=77		
		1	SA-. 57 34			
		1	SA-. 57 30			
		1	SA-. 57 26			
		1	SA-. 57 22			
16	503 912 0	4	AM16x1,5	DIN 7604	Verschlussschraube	Screw plug
17	515 004 0	4	C16x20	DIN 7603	Dichtring	Sealing ring
18	32 250 00 57 0	1			Verschlussschraube	Screw plug
19	515 004 0	1	C16x20	DIN 7603	Dichtring	Sealing ring
20	500 859 0	10	M8x80	ISO 4762	Zyl-Schraube	Socket head cap screw
21	506 839 0	10	S8		Sicherungsscheibe	Locking disc
22	504 960 0	2	8m6x24	ISO 2338	Zyl-Stift	Dowel pin



Getriebe / gear

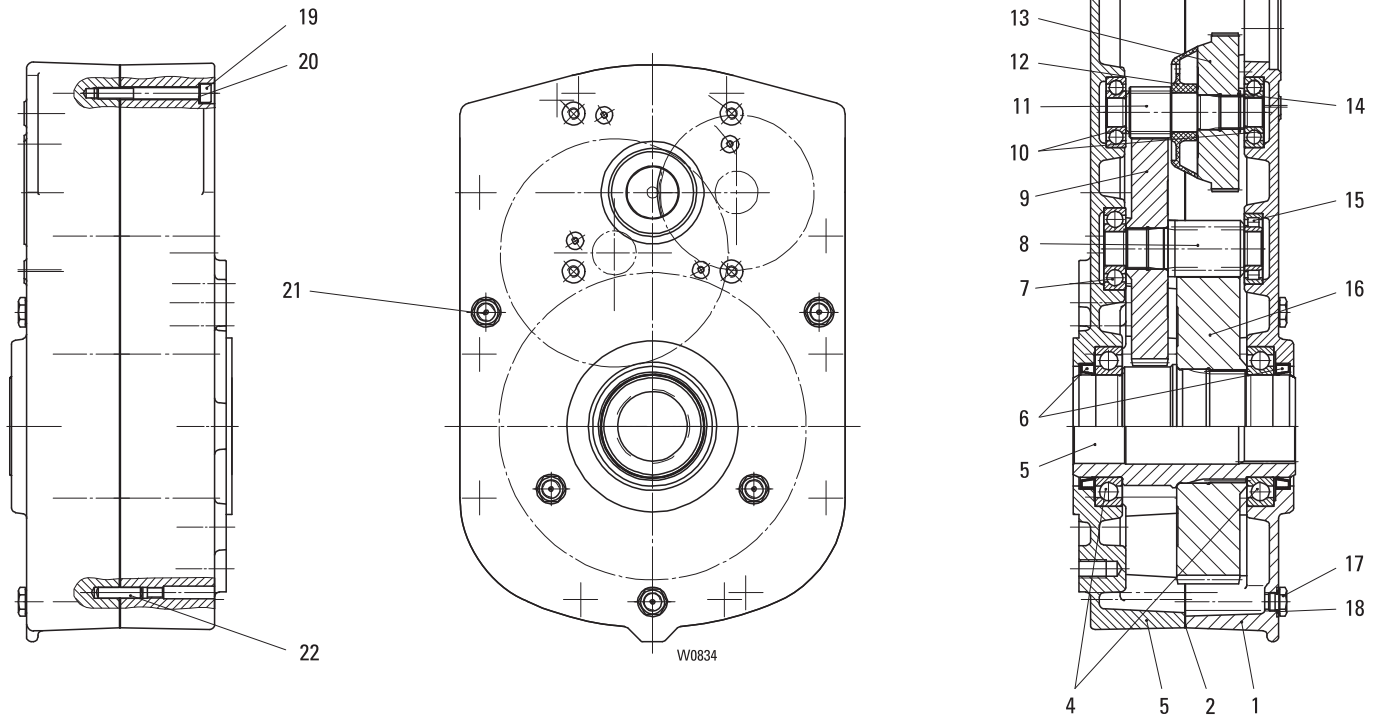

Pos	Teil-Nummer Part-Number	Stück Piece	Beschreibung Description	Benennung Designation	
	16 270 09 30 0	1	SA-. 67 46 (Pos.1-22)	Getriebe Gear	
	16 270 10 30 0	1	SA-. 67 44 (Pos.1-22)		
	16 270 11 30 0	1	SA-. 67 42 (Pos.1-22)		
	16 270 12 30 0	1	SA-. 67 40 (Pos.1-22)		
	16 270 13 30 0	1	SA-. 67 38 (Pos.1-22)		
	16 270 14 30 0	1	SA-. 67 36 (Pos.1-22)		
	16 270 15 30 0	1	SA-. 67 34 (Pos.1-22)		
	16 270 16 30 0	1	SA-. 67 32 (Pos.1-22)		
	16 270 17 30 0	1	SA-. 67 30 (Pos.1-22)		
	16 270 18 30 0	1	SA-. 67 28 (Pos.1-22)		
	16 270 19 30 0	1	SA-. 67 26 (Pos.1-22)		
1	16 277 02 01 0	1			Getriebegehäuse Gear box
2	34 255 00 95 0	1			Dichtung Seal
3	16 277 02 02 0	1		Getriebedeckel Gear cover	
4	560 113 0	2	16018-C3 DIN 625	Rillenkugellager Grooved ball bearing	
5	16 277 01 23 0	1		Abtriebswelle Drive shaft	
6	561 806 0	2	A90x110x12 DIN 3760	Wellendichtring Shaft seal	
7	560 168 0	1	6306 DIN 625	Rillenkugellager Grooved ball bearing	
8	16 277 13 19 0	1	SA-. 67 46 z=11	Ritzelwelle Pinion	
		1	SA-. 67 42		
		1	SA-. 67 40		
		1	SA-. 67 36		
		1	SA-. 67 32		
	16 277 14 19 0	1	SA-. 67 28 z=13		
		1	SA-. 67 44		
		1	SA-. 67 38		
		1	SA-. 67 34		
		1	SA-. 67 30		
		1	SA-. 67 26		



Pos	Teil-Nummer Part-Number	Stück Piece	Beschreibung Description	Benennung Designation	Designation	
9	16 277 16 11 0	1	SA-. 67 46	z=80	Zahnrad	Toothed wheel
		1	SA-. 67 44			
		1	SA-. 67 40			
		1	SA-. 67 38			
	16 277 15 11 0	1	SA-. 67 42	z=73		
		1	SA-. 67 36			
		1	SA-. 67 34			
	16 277 14 11 0	1	SA-. 67 32	z=64		
		1	SA-. 67 30			
		1	SA-. 67 28			
1		SA-. 57 26				
10	560 020 0	2	6305	DIN 625	Rillenkugellager	Grooved ball bearing
11	16 277 10 19 0	1	SA-. 67 46	z=15	Ritzelwelle	Pinion
		1	SA-. 67 44			
		1	SA-. 67 40			
		1	SA-. 67 38			
	16 277 11 19 0	1	SA-. 67 42	z=22		
		1	SA-. 67 36			
		1	SA-. 67 34			
	16 277 12 19 0	1	SA-. 67 32	z=31		
		1	SA-. 67 30			
		1	SA-. 67 28			
1		SA-. 67 26				
12	34 255 00 39 0	1			Ölleitring	Oil splash ring
13	16 277 11 11 0	1	SA-. 67 46	z=125	Zahnrad	Toothed wheel
		1	SA-. 67 44			
		1	SA-. 67 42			
		1	SA-. 67 40			
	16 277 12 11 0	1	SA-. 67 38	z=80		
		1	SA-. 67 36			
		1	SA-. 67 34			
		1	SA-. 67 32			
		1	SA-. 67 30			
		1	SA-. 67 28			
16 277 13 11 0	1	SA-. 67 26	z=51			
	1	SA-. 67 26				
14	506 812 0	1	29x1,5	DIN 471	Sicherungsring	Circlip
15	560 208 0	1	NJ 206 EC	DIN 5412	Zyl-Rollenlager	Roller bearing
16	16 277 18 11 0	1	SA-. 67 46	z=78	Zahnrad	Toothed wheel
		1	SA-. 67 42			
		1	SA-. 67 40			
		1	SA-. 67 36			
	16 277 17 11 0	1	SA-. 67 32	z=75		
		1	SA-. 67 28			
		1	SA-. 67 44			
		1	SA-. 67 38			
		1	SA-. 67 34			
		1	SA-. 67 30			
17	503 912 0	4	AM16x1,5	DIN 7604	Verschlussschraube	Screw plug
18	515 004 0	5	C16x20	DIN 7603	Dichtring	Sealing ring
19	500 237 0	10	M10x90	ISO4762-8.8	Zyl-Schraube	Socket head cap screw
20	506 904 0	10	10	DIN 7980	Federring	Spring washer
21	32 250 00 57 0	1			Verschlussschraube	Screw plug
22	504 969 0	2	10m6x40	ISO 2338	Zyl-Stift	Dowel pin

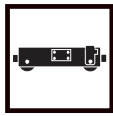

Originalteile
Original parts
SF 15

STAHL
CraneSystems

Drehmomentstütze / torque support

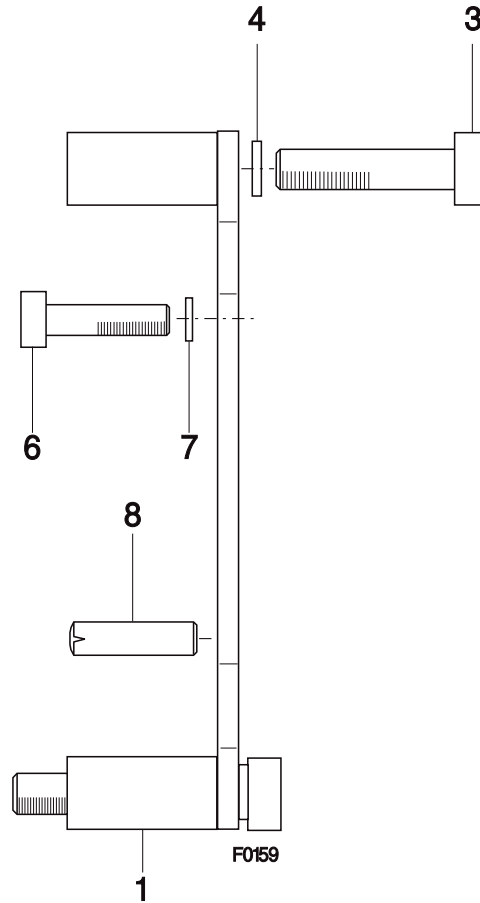

Pos	Teil-Nummer Part-Number	Stück Piece	Beschreibung Description	Benennung	Designation
1	21 270 01 22 0	1	SF1 (Pos.3-8)	Drehmomentstütze	Torque support
3	500 980 0	4	M8x45 DIN 912-8.8	Zyl-Schraube	Socket head cap screw
4	506 839 0	4	S8	Sicherungsscheibe	Locking disc
6	500 144 0	4	M8x16 DIN 912-8.8	Zyl-Schraube	Socket head screw
7	506 839 0	4	S8	Sicherungsscheibe	Locking disc
8	504 960 0	2	8m6x24 DIN 7	Zyl-Stift	Pin



Drehmomentstütze / torque support

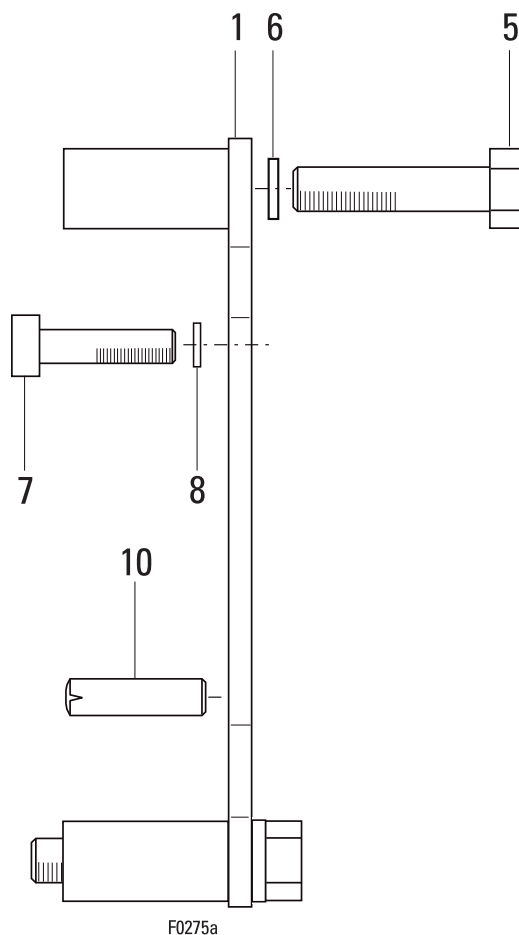

F0275a

Pos	Teil-Nummer Part-Number	Stück Piece	Beschreibung Description	Benennung	Designation
1	22 270 01 22 0	1	SF 25 (Pos.5-10)	Drehmomentstütze	Torque support
5	500 205 0	4	M12x50 ISO 4014	Skt-Schraube	Haxon head cap screw
6	507 104 0	4	SKM12	Sperrkantscheibe	Lock washer
7	500 234 0	4	M8x25 8.8 ISO 4762	Zyl-Schraube	Socket head screw
8	506 839 0	4	S8	Sicherungsscheibe	Locking disc
10	504 960 0	2	8m6x24 DIN 7	Zyl-Stift	Pin



Drehmomentstütze / torque support

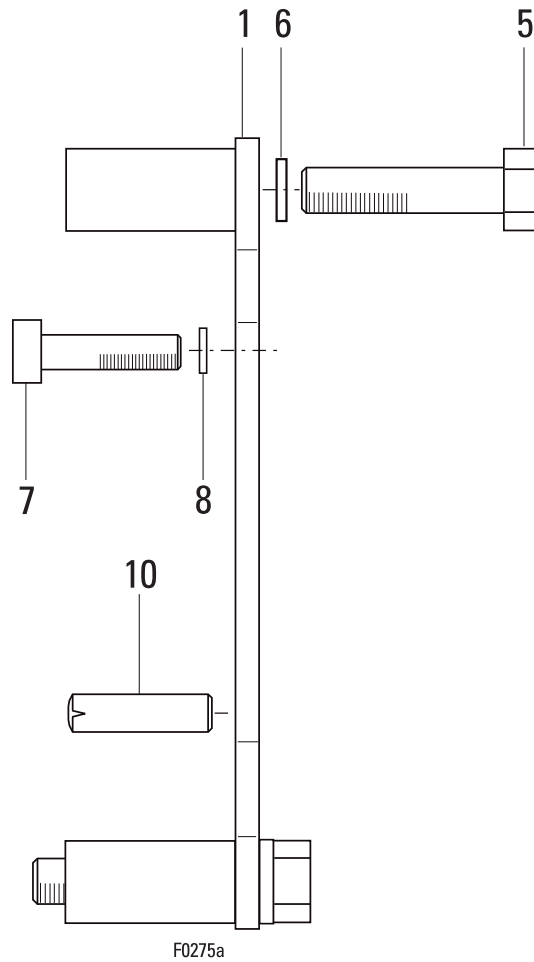

F0275a

Pos	Teil-Nummer Part-Number	Stück Piece	Beschreibung Description	Benennung Designation	Designation
1	23 270 06 22 0	1	(Pos.5-10)	Dehmomentstütze	Torque support
5	500 208 0	4	M12x65 ISO 4014-8.8	Skt-Schraube	Hexagon head cap screw
6	507 104 0	4	SKM 12 ISO 4762	Sperrkantscheibe	Lock washer
7	500 148 0	4	M10x25 8.8	Zyl-Schraube	Socket head screw
8	506 840 0	4	S10 DIN 7	Sicherungsscheibe	Locking disc
10	504 835 0	2	10m6x28	Zyl-Stift	Pin

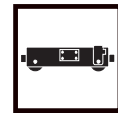

Drehmomentstütze / torque support

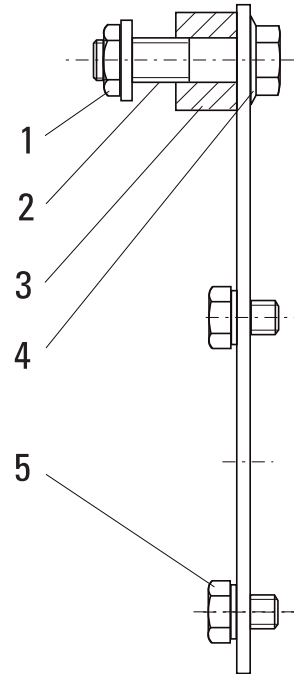
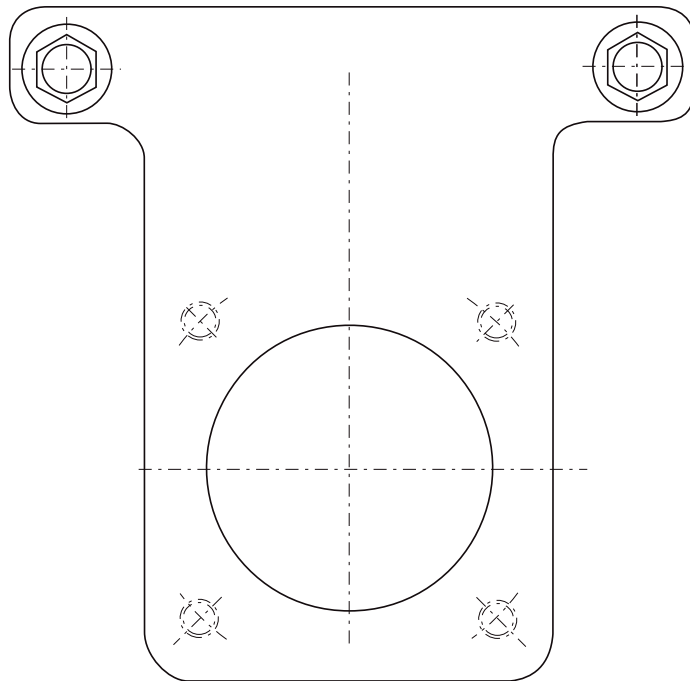

W0836

Pos	Teil-Nummer Part-Number	Stück Piece	Beschreibung Description	Benennung	Designation
1	15 270 03 22 0	1	SA-. 5 (Pos.1-5)	Drehmomentstütze	Torque support
	15 270 04 22 0	1	SA-. 5 (FE-A315) (Pos.1-5)		
	15 270 05 22 0	1	SA-. 5 (FE-A400) (Pos.1-5)		
	15 270 09 22 0	1	SA-. 5 K.L-E 315 (Pos.1-5)		
2	507 840 0	2	M12	Sicherungsmutter Skt-Schraube	Locknut Heyagon head cap screw
	500 356 0	2	M12x70 ISO 4014-8.8		
3	500 357 0	2	M12x90 (FE-A315) ISO 4014-8.8	Buchse Distanzstück Distanzstück Buchse Sperrkantscheibe	Bushing Bushing Bushing Bushing Disc
	500 933 0	2	M12x80 (FE-A400) ISO 4014-8.8		
	500 208 0	2	M12x65 K.L-E 315 EN 24014-8.8		
	15 277 02 52 0	2	30/13/26 (FE-A315)		
	16 277 01 55 0	2	(FE-A400)		
4	16 277 00 55 0	2	(FE-A400)	Buchse Sperrkantscheibe	Bushing Disc
	15 277 03 52 0	2	K.L-E 315		
5	507 104 0	2	SKM 12	Sicherungsschraube	Safety bolt
	501 122 0	4	M12x25-10		



Originalteile
Original parts
SA-C 67

STAHL
CraneSystems

Drehmomentstütze / torque support

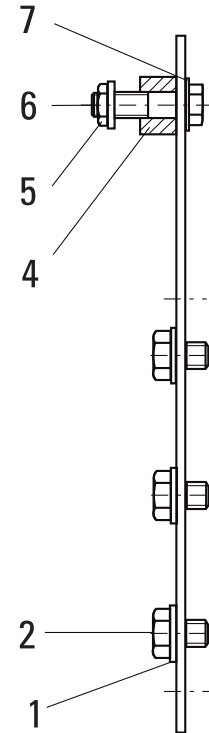
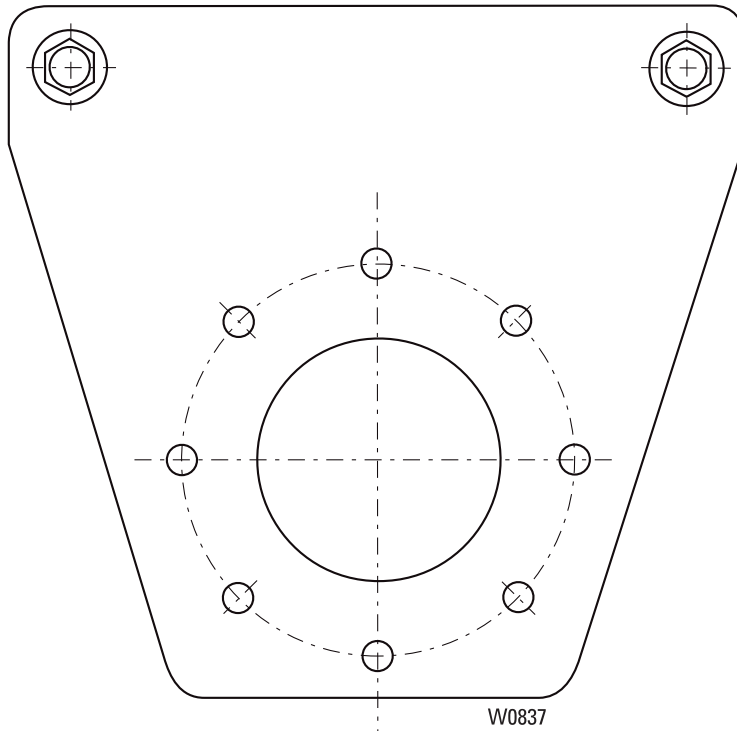

Pos	Teil-Nummer Part-Number	Stück Piece	Beschreibung Description	Benennung	Designation
	16 270 00 22 0	1	(Pos.1-7)	Drehmomentstütze	Torque support
1	562 953 0	6	16 DIN 6797	Spannscheibe	Disc
2	500 337 0	6	M16x30 ISO 4017-8.8	Skt-Schraube	Hexagon head cap screw
4	16 277 01 52 0	2	40/17/22	Buchse	Bushing
5	507 841 0	2	M16	Sicherungsmutter	Locknut
6	500 213 0	2	M16x70 ISO 4014-8.8	Skt-Schraube	Hexagon head cap screw
7	562 953 0	2	16 DIN 6797	Spannscheibe	Disc

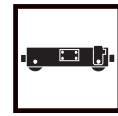

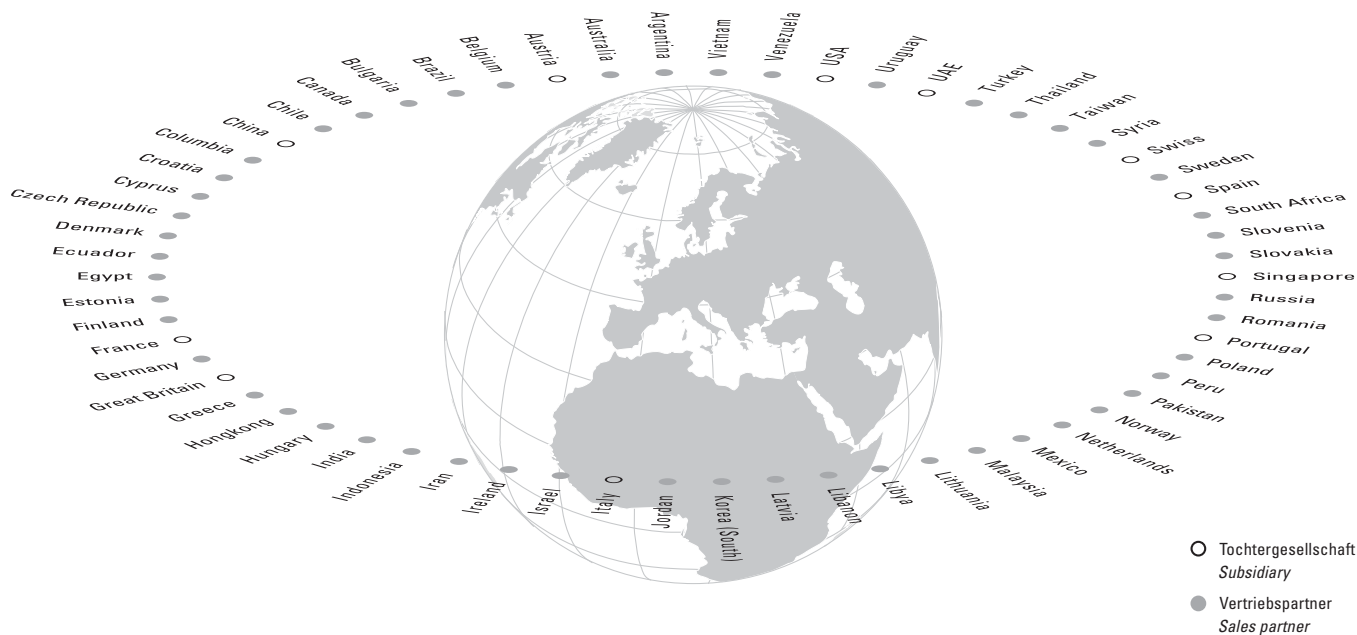

○ **Tochtergesellschaft/Subsidiary**

Austria
Steyregg
Tel +43 732 641111-0
Fax +43 732 641111-33
office@stahlcranes.at

Great Britain
Birmingham
Tel +44 121 7676400
Fax +44 121 7676485
info@stahlcranes.co.uk

Portugal
Lissabon
Tel +351 21 44471-60
Fax +351 21 44471-69
ferrometal@ferrometal.pt

Switzerland
Däniken
Tel +41 62 82513-80
Fax +41 62 82513-81
info@stahlcranes.ch

China
Shanghai
Tel +86 21 6257 2211
Fax +86 21 6254 1907
service_cn@stahlcranes.cn

India
Chennai
Tel +91 44 4352-3955
Fax +91 44 4352-3957
indiasales@stahlcranes.in

Singapore
Singapore
Tel +65 6271 2220
Fax +65 6377 1555
sales@stahlcranes.sg

United Arab Emirates
Dubai
Tel +971 4 805-3700
Fax +971 4 805-3701
info@stahlcranes.ae

France
Paris
Tel +33 1 39985060
Fax +33 1 34111818
info@stahlcranes.fr

Italy
S. Colombano
Tel +39 0185 358391
Fax +39 0185 358219
info@stahlcranes.it

Spain
Madrid
Tel +34 91 484-0865
Fax +34 91 490-5143
info@stahlcranes.es

USA
Charleston, SC
Tel +1 843 767-1951
Fax +1 843 767-4366
sales@stahlcranes.us

● **Vertriebspartner/Sales partner**

Die Adressen von über 100 Vertriebspartnern weltweit finden Sie im Internet auf www.stahlcranes.com unter Kontakt.
You will find the addresses of over 100 sales partners on the Internet at www.stahlcranes.com under Contact.

➔ www.stahlcranes.com

STAHL CraneSystems GmbH, Daimlerstr. 6, 74653 Künzelsau, Germany
Tel +49 7940 128-0, Fax +49 7940 55665, marketing@stahlcranes.com

